

BUSH HOG®

Estate Series Zero Turn Mower



BUSH HOG®
Performance You Can Count On™

ASSEMBLY ● OPERATION ● MAINTENANCE

CONGRATULATIONS!

You have invested in the best implement of its type on the market today.

The care you give your Bush Hog implement will greatly determine your satisfaction with its performance and its service life. We urge a careful study of this manual to provide you with a thorough understanding of your new implement before operating, as well as suggestions for operation and maintenance.

If your manual should become lost or destroyed, Bush Hog will be glad to provide you with a new copy. Order from Bush Hog, P. O. Box 1039, Selma, Alabama 36702-1039. Most of our manuals can also be downloaded from our website at www.bushhog.com.

As an authorized Bush Hog dealer, we stock genuine Bush Hog parts which are manufactured with the same precision and skill as our original equipment. Our trained service personnel are well informed on methods required to service Bush Hog equipment, and are ready and able to help you.

Should you require additional information or assistance, please contact us.

YOUR AUTHORIZED
BUSH HOG DEALER

BECAUSE BUSH HOG MAINTAINS AN ONGOING PROGRAM OF PRODUCT IMPROVEMENT, WE RESERVE THE RIGHT TO MAKE IMPROVEMENTS IN DESIGN OR CHANGES IN SPECIFICATIONS WITHOUT INCURRING ANY OBLIGATION TO INSTALL THEM ON UNITS PREVIOUSLY SOLD.

BECAUSE OF THE POSSIBILITY THAT SOME PHOTOGRAPHS IN THIS MANUAL WERE TAKEN OF PROTOTYPE MODELS, PRODUCTION MODELS MAY VARY IN SOME DETAIL. IN ADDITION, SOME PHOTOGRAPHS MAY SHOW SHIELDS REMOVED FOR PURPOSES OF CLARITY. **NEVER OPERATE** THIS IMPLEMENT WITHOUT ALL SHIELDS IN PLACE.

ESTATE SERIES ZERO TURN RIDERS

TABLE OF CONTENTS

| SECTION | PAGE | SECTION | PAGE |
|--|------|---|------|
| Warranty | 2 | Mower Blades | 14 |
| Dealer Preparation Check List | 3 | Neutral Adjustment | 15 |
| Safety Precautions | 4 | Motion Control Neutral Adjustment | 15 |
| I INTRODUCTION AND DESCRIPTION | 8 | Control Lever Adjustment | 15 |
| Introduction | 8 | Leveling The Deck | 16 |
| Description | 8 | Deck Belt Adjustment | 16 |
| Specifications | 9 | Deck Belt Replacement | 16 |
| II OPERATION | 10 | Hydrostatic Belt Adjustment | 17 |
| General Safety | 10 | Hydrostatic Belt Replacement | 17 |
| Pre-Operation Checklist | 10 | Start Up Maintenance | 17 |
| Operation | 10 | Hydrostatic Transaxle Maintenance | 17 |
| Mowing Recommendations | 12 | Purging Procedures | 18 |
| III MAINTENANCE | 13 | Parking Brake Adjustment | 18 |
| Maintenance Schedule | 13 | Troubleshooting | 19 |
| Engine | 14 | IV ASSEMBLY | 20 |
| Battery | 14 | Safety Decals | 21 |
| Tires | 14 | Torque Specifications | 23 |

RETAIL CUSTOMER'S RESPONSIBILITY UNDER THE BUSH HOG WARRANTY

It is the Retail Customer and/or Operator's responsibility to read the Operator's Manual, to operate, lubricate, maintain and store the product in accordance with all instructions and safety procedures. Failure of the operator to read the Operator's Manual is a misuse of this equipment.

It is the Retail Customer and/or Operator's responsibility to inspect the product and to have any part(s) repaired or replaced when continued operation would cause damage or excessive wear to other parts or cause a safety hazard.

It is the Retail Customer's responsibility to deliver the product to the authorized Bush Hog Dealer, from whom he purchased it, for service or replacement of defective parts which are covered by warranty. Repairs to be submitted for warranty consideration must be made within forty-five (45) days of failure.

It is the Retail Customer's responsibility for any cost incurred by the Dealer for traveling to or hauling of the product for the purpose of performing a warranty obligation or inspection.



ESTATE SERIES ZERO TURN RIDER LIMITED WARRANTY



Bush Hog warrants to the original purchaser that this new Bush Hog Estate Rider, purchased from an authorized Bush Hog dealer, that the equipment be free from defects in material and workmanship for a period of two (2) years from date of retail sale when purchased for residential use. "Residential use" means use on the same property as the purchasers' home. The obligation of Bush Hog to the purchaser under this warranty is limited to the repair or replacement of defective parts. **NOTE: The spindle assemblies have a three (3) year limited warranty. This warranty covers parts and labor for the first two years and parts only during the third year.**

Replacement or repair parts installed in the equipment covered by this limited warranty are warranted for ninety (90) days from the date of purchase of such part or to the expiration of the applicable new equipment warranty period, whichever occurs later. Warranted parts shall be provided at no cost to the user at an authorized Bush Hog dealer during regular working hours. Bush Hog reserves the right to inspect any equipment or parts which are claimed to have been defective in material or workmanship.

DISCLAIMER OF IMPLIED WARRANTIES & CONSEQUENTIAL DAMAGES

Bush Hog's obligation under this limited warranty, to the extent allowed by law, is in lieu of all warranties, implied or expressed, **INCLUDING IMPLIED WARRANTIES OF MERCHANTABILITY AND FITNESS FOR A PARTICULAR PURPOSE** and any liability for incidental and consequential damages with respect to the sale or use of the items warranted. Such incidental and consequential damages shall include but not be limited to: transportation charges other than normal freight charges; cost of installation other than cost approved by Bush Hog; duty; taxes; charges for normal service or adjustment; loss of crops or any other loss of income; rental of substitute equipment, expenses due to loss, damage, detention or delay in the delivery of equipment or parts resulting from acts beyond the control of Bush Hog.

THIS LIMITED WARRANTY SHALL NOT APPLY:

1. To transportation to and from dealership or service calls made by dealers, ie, driving time, towing, pickup and delivery.
2. To vendor items which carry their own warranties, such as engines, batteries, tires, and tubes.
3. If the unit has been subjected to misapplication, abuse, misuse, negligence, fire or other accident.
4. If parts not made or supplied by Bush Hog have been used in connection with the unit, if, in the sole judgement of Bush Hog such use affects its performance, stability or reliability.
5. If the unit has been altered or repaired outside of an authorized Bush Hog dealership in a manner which, in the sole judgement of Bush Hog, affects its performance, stability or reliability.
6. To normal maintenance service and normal replacement items such as gearbox lubricant, hydraulic fluid, worn blades, or to normal deterioration of such things as belts and exterior finish due to use or exposure.
7. To expendable or wear items such as teeth, chains, sprockets, belts, springs and any other items that in the company's sole judgement is a wear item.

NO EMPLOYEE OR REPRESENTATIVE OF BUSH HOG IS AUTHORIZED TO CHANGE THIS LIMITED WARRANTY IN ANY WAY OR GRANT ANY OTHER WARRANTY UNLESS SUCH CHANGE IS MADE IN WRITING AND SIGNED BY BUSH HOG'S SERVICE MANAGER, POST OFFICE BOX 1039, SELMA, ALABAMA 36702-1039.



Record the model number, serial number and date purchased. This information will be helpful to your dealer if parts or service are required.

MODEL NUMBER _____

MAKE CERTAIN THE WARRANTY REGISTRATION CARD HAS BEEN FILED WITH BUSH HOG/ SELMA, ALABAMA

SERIAL NUMBER _____

DATE OF RETAIL SALE _____

DEALER PREPARATION CHECK LIST

ESTATE SERIES ZERO TURN RIDER

BEFORE DELIVERING MACHINE — The following check list should be completed.
Use the Operator's Manual as a guide.

- 1. Engine has been serviced.
- 2. Battery fluid level is checked.
- 3. Low oil pressure warning light checked for operation.
- 4. Operator interlock switches checked for operation.
- 5. Assembly completed.
- 6. All fittings lubricated.
- 7. All shields in place and in good condition.
- 8. All fasteners torqued to specifications given in Torque Chart.
- 9. All decals in place and readable. (See decal page.)
- 10. Overall condition good (i.e. paint, welds)
- 11. Parking brake checked and adjusted, if necessary.
- 12. Steering checked and adjusted, if necessary.
- 13. Check tire pressure.
- 14. Operator's manual has been delivered to owner and he has been instructed on the safe and proper use of the cutter.

Dealer's Signature _____

Purchaser's Signature _____

THIS CHECKLIST TO REMAIN IN OWNER'S MANUAL

It is the responsibility of the dealer to complete the procedures listed above before delivery of this implement to the customer.

Safety Alert Symbol



This Safety Alert Symbol means: “**ATTENTION! BECOME ALERT! YOUR SAFETY IS INVOLVED!**”

This symbol is used to call attention to safety precautions that should be followed by the operator to avoid accidents. When you see this symbol, carefully read the message that follows and heed its advice. Failure to comply with safety precautions could result in death or serious bodily injury.

Safety Signs *Signal Words*

The signal words **DANGER, WARNING, AND CAUTION** are used on the equipment safety signs. These words are intended to alert the viewer to the existence and the degree of hazard seriousness.

 **DANGER**

White letters on **RED**

This signal word indicates a potentially hazardous situation which, if not avoided, will result in death or serious injury.

 **WARNING**

Black letters on **ORANGE**

This signal word indicates a potentially hazardous situation which, if not avoided, could result in death or serious injury

It may also be used to alert against unsafe practices.

 **CAUTION**

Black letters on **YELLOW**

This signal word indicates a potentially hazardous situation exist which, if not avoided, may result in minor or moderate injury.

It may also be used to alert against unsafe practices.

IMPORTANT SAFETY PRECAUTIONS

This symbol is used to call attention to safety precautions that should be followed by the operator to avoid accidents. When you see this symbol, carefully read the message that follows and heed its advice. Failure to comply with safety precautions could result in serious bodily injury.



In addition to the design and configuration of equipment, hazard control and accident prevention are dependent upon the awareness, concern, prudence and proper training of personnel in the operation, transport, maintenance and storage of equipment. Lack of attention to safety can result in accident, personal injury, reduction of efficiency and worst of all—loss of life. Watch for safety hazards and correct deficiencies promptly. Use the following safety precautions as a general guide to safe operations when using this machine. Additional safety precautions are used throughout this manual for specific operating and maintenance procedures. Read this manual and review the safety precautions often until you know the limitations.

ACCIDENT PATTERNS TO AVOID

1. CONTACT WITH THE ROTATING BLADE - This accident usually happens when the operator is clearing the discharge chute of grass, (especially when the grass is wet), or when the operator adjusts the machine without turning it off and waiting for the blades to completely stop.
2. PROPELLED OBJECTS - Sticks, rocks, wires, and other objects can be propelled out through the discharge chute or from under the mower housing. Avoid discharging toward persons and against walls or obstructions. Material may ricochet toward operator.
3. GRASS DISCHARGE CHUTE - The mower shall not be operated without the grass discharge chute in its lowered position. Do not mow without grass discharge chute or grass catcher in place.
4. OVERTURNING - This happens when riding mowers are used on steep slopes, embankments or hills. The operator in these cases can come in contact with blades or sustain injuries during a fall.
5. MOWER RUNNING OVER THE VICTIM - This usually happens when a riding mower is driven in reverse. The accident victims are most often young children whom, unseen by the operator of the mower, were in the area being mowed. Before and while backing, look behind and down for small children. Be alert and turn machine off if a child enters the area.

WE SHARE YOUR DESIRE TO PROTECT YOURSELF, YOUR FAMILY, YOUR FRIENDS AND YOUR NEIGHBORS FROM ACCIDENTAL INJURY. OBSERVING AND ENFORCING THE FOLLOWING GUIDE LINES WILL HELP TO INSURE THE SAFETY OF EVERYONE.

SAFETY INSTRUCTIONS AND RECOMMENDATIONS

1. PEOPLE WHO OPERATE, SERVICE, OR ARE OTHERWISE ASSOCIATED with the Zero Turn Mower should be trained in its proper use and warned of its dangers. Before operating, adjusting, or servicing the Zero Turn Mower they should read and understand this entire manual and the engine manual.
2. Do not operate machine while under the influence of alcohol or drugs.
3. A large percentage of riding mower-related injuries data indicates operators age 60 years and above are involved in these accidents. Protect yourself and others from serious injury. Evaluate your ability for a safe riding mower operation.
4. AVOID CONTACT WITH MOVING PARTS. Keep hands and feet from under mowing deck and away from blades at all times. Turn engine (motor) off if you must unclog the chute.

5. AVOID HILLS AND SLOPES. Use **EXTREME** caution when mowing and/or turning on slopes as loss of traction and/or tip-over could occur. Drive slower on slopes. **DO NOT** mow slopes greater than 15 degrees. Watch for ditches, holes, rocks, dips and rises, which change the operating angle. Keep away from drop-offs and steep banks. Avoid sudden starts when mowing uphill - mower may tip backwards. Loss of traction may occur going downhill - weight transfer to the front wheels may cause drive wheels to slip and cause loss of braking. **DO NOT** mow slopes when grass is wet - slippery conditions affect steering and reduce traction and braking. The operator is responsible for safe operation on slopes.
6. DISENGAGE POWER TO MOWER BEFORE BACKING UP. Do not mow in reverse unless absolutely necessary and then only after turning around and observing the entire area behind the mower. Go slowly. Most "running over victim" accidents occur in reverse.
7. BEGINNING OPERATORS SHOULD LEARN HOW TO STEER the Zero Turn Mower before attempting to mow. Start with slow engine speed and drive without the blades engaged in open area until comfortable with the machine.
8. KNOW HOW TO STOP QUICKLY. Know the location and operation of every control, especially how to brake and how to disengage the mower blades.
9. DO NOT MOVE THE CONTROL LEVERS from forward position to reverse position rapidly. The speed and/or direction of travel is affected instantly by movement of the Control Levers.
10. DO NOT ALLOW CHILDREN TO OPERATE MOWER. Do not allow others who have not had instructions to operate mower.
11. ALWAYS TURN ENGINE OFF AND REMOVE KEY before leaving mower to prevent children and inexperienced operators from starting the engine. Never leave the mower unattended with engine running. Always wait for all moving parts and all sounds to stop before leaving operator's seat. Always set the parking brake on an unattended mower.
12. WEAR STURDY, ROUGH-SOLED WORK SHOES AND CLOSE-FITTING SLACKS AND SHIRTS. Never operate mower in bare feet, sandals or sneakers.
13. WEAR PERSONAL PROTECTIVE EQUIPMENT such as, but not limited to, protection for eyes, ears, feet, hands and head when operating or repairing equipment. Do not wear loose clothing or jewelry that may catch on equipment moving parts.
14. NEVER CARRY PASSENGERS.
15. KNOW THE AREA YOU ARE TO MOW. Watch for hidden dangers such as rocks, roots, sticks, holes, bumps, and drop-offs, etc. Before mowing, pick up all debris in area to be mowed. Sharp and hard objects can be propelled at a high speed and can act like shrapnel. Walk through tall grass BEFORE MOWING to make sure there are no hidden dangers. Mow higher than desired in tall grass to expose any hidden objects and/or obstacles, clean the area, and then mow to the desired height.
16. BE SURE THE AREA IS CLEAR of other people before mowing. Stop machine if anyone enters the area.
17. Use extreme care when approaching blind corners, shrubs, trees, or other objects that may block your view of a child.
18. NEVER REFUEL A MOWER INDOORS. Allow the engine time to cool before refueling. Unseen vapors may be ignited by a spark. Always clean up spilled gasoline. Never run the engine indoors in a garage or any other closed building. Allow engine to cool before storing in any enclosure. The engine exhaust and gasoline fumes are dangerous.
19. NEVER REMOVE THE FUEL CAP or add gasoline to a running or hot engine or an engine that has not been allowed to cool for several minutes after running. Always make sure the gas cap is in place.
20. DO NOT SMOKE AROUND THE MOWER or the gasoline storage container. Gasoline fumes can easily ignite.

21. Use only an approved gasoline container.
22. Avoid fire from static sparks. Never fill gasoline containers inside a vehicle or on a truck or trailer bed with a plastic liner. Always place fuel containers on the ground away from your vehicle before filling.
23. Avoid fire from static sparks. Remove mower from truck bed or trailer and refuel it on the ground. Only use an approved gasoline container and not the gasoline dispenser to refuel when the mower remains on trailer or truckbed.
24. Avoid fire from static sparks. During refueling, keep nozzle in contact with fuel tank or fuel container opening at all times. Avoid over filling, do not use nozzle lock-open device.
25. KEEP GASOLINE IN A WELL-VENTILATED AREA away from your living quarters and in tightly capped safety cans. Never store mower with gasoline in the tank inside a building where fumes may reach open flame or spark.
26. DISENGAGE BLADES, STOP ENGINE, ENGAGE PARKING BRAKE, DISCONNECT BATTERY AND REMOVE IGNITION KEY before any servicing. Be sure all moving parts and all sounds have stopped. Let engine cool and disconnect the spark plugs so the engine cannot start by accident.
27. KEEP ALL NUTS, BOLTS, AND SCREWS TIGHT to be sure equipment is in safe working condition, especially blade bolts.
28. VEHICLE SHOULD BE STOPPED AND INSPECTED FOR DAMAGE after striking a foreign object and the damage should be repaired before restarting and operating the equipment. Stop immediately and check for damage or loose parts if mower should start vibrating.
29. DISENGAGE BLADES BEFORE DRIVING ACROSS WALKS or projecting objects.
30. KEEP SAFETY DEVICES AND GUARDS IN PLACE. If any of the safety switches become inoperable, have them repaired immediately.
31. DO NOT STEP OR STAND ON THE MOWER HOUSING. Step or stand only on the tread areas on the deck.
32. WATCH OUT FOR TRAFFIC near roadways and when crossing roads.
33. THIS MACHINE IS NOT MEANT FOR HIGHWAY OR STREET USE. It is not a recreational vehicle and it should not be operated as such.
34. DO NOT USE MOWER WHEN GRASS IS WET OR SLIPPERY.
35. MOW ONLY DURING DAYLIGHT unless ZT is equipped with optional working lights kit.
36. ALWAYS DISENGAGE THE MOWER BLADE CLUTCH when transporting.

SECTION I INTRODUCTION AND DESCRIPTION



INTRODUCTION

We are pleased to have you as a Bush Hog customer. Your Bush Hog Estate Series ZT Rider has been carefully designed to give maximum service with minimum down time. This manual is provided to give you the necessary operating and maintenance instructions for keeping your mower in top operating condition. Please read this manual thoroughly. Understand what each control is for and how to use it. Observe all safety precautions decal on the machine and noted throughout the manual for safe operation of the implement. If any assistance or additional information is needed, contact your authorized Bush Hog dealer.

NOTE:

All references made to right, left, front, rear, top or bottom is as viewed facing the direction of forward travel.

DESCRIPTION

The Estate ZT is intended for use on large lawns and other frequently maintained areas where a smooth, even cut is desired and superior maneuver-

ability is needed. The unit consists of either a 17 hp Briggs & Stratton single, 18 hp Briggs & Stratton twin, 20 hp Kohler twin or a 20 hp Honda twin engine. The engine has a pressurized oil lubrication system with spin-on type filter, fused electronic ignition, electric start and a 6.5 gallon fuel system.

Two Zero Turn hydrostatic transaxles are used for propelling and steering. The pumps are belt driven by the engine output shaft. One lever for each drive controls both speed and direction. This independent control of each drive wheel coupled with continuously variable speed selection gives the Zero Turn mower exceptional maneuverability.

The mower deck is driven by a v-belt from the engine. An electro magnetic clutch is used to engage/disengage the PTO.

The mower attachment is available in 44" or 52" cutting widths. The mower has three uplift blades, driven by a single V-belt controlled by a spring loaded tensioner.

CONTROLS

OPERATOR INTERLOCK SYSTEM

Your Bush Hog Zero Turn Rider is equipped with an Operator Interlock System that is designed to help prevent possible serious injuries. Understanding and maintaining this system is vital for safe operation.

To Start Engine:

1. Blades (PTO) must be disengaged.
2. Control levers in neutral (swung out).
3. Parking brake on.
4. Operator in seat.

The Engine Will Kill If:

1. The operator leaves the seat with:
 - a. The control levers out of neutral (swung in).
 - b. The blades are engaged.
 - c. The parking brake is off.
 - d. All of the above.
2. The park brake is on before the control levers are in neutral (swung out).

DO NOT OPERATE MOWER IF SAFETY SWITCHES ARE NOT OPERATING PROPERLY.

WARNING

DO NOT OPERATE MACHINE UNLESS INTERLOCK SYSTEM FUNCTIONS PROPERLY. FAILURE TO HEED THIS WARNING MAY RESULT IN SERIOUS INJURY, DEATH OR EQUIPMENT DAMAGE.

TRACTOR SPECIFICATIONS

Width - (For 44" Deck) 42"
 (For 52" Deck) 44"

Height - To top of seat back (Standard Seat) 44"
 (Suspension Seat) 48"

Fuel Capacity (In Twin Tanks) 6.5 gallons

Hydrostatic Transaxles - All Models (2) Hydro-Gear C-IZT

Engines - 17 hp Briggs & Stratton Intek
 18 hp Briggs & Stratton Intek Twin
 20 hp Kohler Command Twin
 20 hp Honda GXV620 Twin

Tires - All Models - Front 11 x 4.0 - 5
 Drive 18 x 8.5 - 8 (44")
 18 x 9.5 - 8 (52")

CONTROL LOCATIONS

- ① Ignition Key - On right hand control console.
- ② Engine Throttle - On right hand control console.
- ③ Two Steering/Speed Control Levers - In front of seat at side. (Shown on page 20)
- ④ PTO Clutch Switch - On right hand control console.
- ⑤ Parking Brake Lever - On left side of operator. (Shown on page 12)
- ⑥ Blade Height Adjust Pin - Right side of deck. (Shown on page 11)
- ⑦ Choke - On right hand control console.
- ⑧ Hydrostatic Transaxle Bypass Valve - Right hand and left hand sides at rear of unit. (Shown on page 12)
- ⑨ Hour Meter/Service Minder - On right hand control console.
- ⑩ Warning Light - On right hand control console for engine oil pressure.

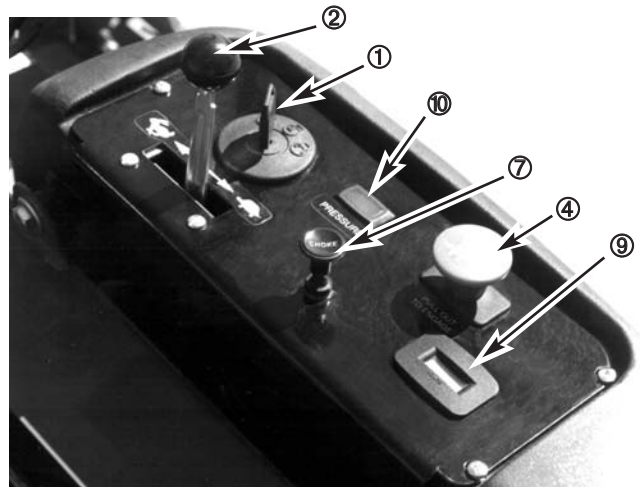

DECK SPECIFICATIONS

| ITEM | | |
|-------------------------------|---|-----|
| Cutting width | 44" | 52" |
| Cutting Height | ----- 1-1/2" to 4-1/2" in 1/4" increments | |
| Blades | 15" | 18" |
| Overall width with chute down | 55" | 64" |
| Material thickness - Deck | -----10 GA.----- | |
| Spindle bearings | -----25 mm----- | |

SECTION II OPERATION

GENERAL SAFETY

Only qualified people familiar with this operator's manual should operate this machine. Operator should wear hard hat, safety glasses, and safety shoes. Avoid loose fitting clothing or jewelry. The operator should read, understand and practice all safety messages shown on the caution, warning and danger decals affixed to the machine to avoid serious injury or death. Before beginning operation, clear work area of any objects that may be picked up and thrown by mower. Check for ditches, stumps, holes or other obstacles that could upset power unit or damage mower. Always push steering levers apart, set parking brake, disengage PTO, turn off engine, and allow blades to come to a complete stop before leaving operator's seat. Do not operate without all shields in place and in good condition.

PRE-OPERATION CHECKLIST

1. Make sure fuel tanks are full. Use regular unleaded gasoline. See engine manual for more details.

WARNING

**AVOID SERIOUS INJURY OR DEATH:
GASOLINE IS EXTREMELY FLAMMABLE AND
EXPLOSIVE UNDER CERTAIN CONDITIONS.**

- REFUEL IN A WELL VENTILATED AREA WITH ENGINE STOPPED.

- DO NOT SMOKE OR ALLOW FLAMES OR SPARKS IN THE REFUELING AREA OR WHERE GASOLINE IS BEING STORED.

- DO NOT OVERFILL FUEL TANK. AFTER REFUELING, MAKE CERTAIN THE TANK CAP IS CLOSED PROPERLY AND SECURELY.

- BE CAREFUL NOT TO SPILL FUEL WHEN REFUELING. FUEL VAPOR OR SPILLED

F U E L
MAY IGNITE. IF ANY FUEL IS SPILLED, MAKE SURE THE AREA IS DRY BEFORE STARTING THE ENGINE.

- KEEP OUT OF REACH OF CHILDREN

AVOID FUEL FIRES BY STATIC ELECTRICITY SPARKS:

- USE ONLY AN APPROVED GASOLINE CONTAINER

- NEVER FILL GASOLINE CONTAINERS INSIDE A VEHICLE OR ON A TRUCK OR TRAILER BED WITH

A
C PLASTIC LINER. ALWAYS PLACE FUEL CONTAINERS ON THE GROUND AWAY FROM YOUR VEHICLE

BEFORE FILLING.

- REMOVE MOWER FROM TRUCK BED OR TRAILER AND REFUEL IT ON THE GROUND. ONLY USE AN APPROVED GASOLINE CONTAINER AND NOT THE GASOLINE DISPENSER TO REFUEL WHEN MOWER REMAINS ON TRAILER OR TRUCK BED.

- DURING REFUELING, KEEP NOZZLE IN CONTACT WITH FUEL TANK OR FUEL CONTAINER OPENING AT ALL TIMES. AVOID OVER FILLING, DO NOT USE NOZZLE LOCK-OPEN DEVICE.

2. Make sure dirt and foreign matter are kept out of fuel tank. Use a clean funnel and fuel can

3. Do not mix oil with gasoline.

4. Do not use white, high test or premium gasoline. Do not use de-icers, carburetor cleaners or othersuch additives.

5. Check the crankcase oil level. Make sure the engine is off. The mower should be parked on a level area. Do not overfill. (See your engine manual for more detailed instructions.)

6. Check the hydrostatic transaxles oil level. (See "Maintenance" section of this manual.)

7. Check battery fluid level.

8. Inspect V-belts

9. Check tire pressure: Front & Drive Tires 9 - 12 psi

10. Make sure underside of mower deck is free of grass.

11. Make sure mower blades are sharp and secured tightly.

12. Clean the air intake screen on the engine if necessary.

13. Perform any other maintenance as it becomes necessary. (See "Maintenance" section)

14. Check parking brake operation by disengaging hydrostatic transaxles (freewheeling position), and placing the brake lever in the "on" position. Attempt to rock tractor by hand. Both drive wheels should be locked. When the brake handle is in the "off" position, both drive wheels should turn freely. If there is a problem in either position, refer to adjustment procedure in the maintenance section.

WARNING

**ENGINE EXHAUST GASES CONTAIN
POISONOUS CARBON MONOXIDE.**

- NEVER RUN ENGINE IN A CLOSED BUILDING OR CONFINED AREA.

- AVOID INHALING EXHAUST GASES.

OPERATION

1. OPEN FUEL SHUT-OFF VALVE left or right tank.

2. MOVE CONTROL LEVERS TO neutral "OUT" position by pushing each one straight sideways.

3. SET PARKING BRAKE. Pull upward to set, locking out in notch.

4. DISENGAGE MOWER BLADE CLUTCH by moving clutch switch to "OFF" (down) position.

5. SET ENGINE CHOKE CONTROL for cold starts to full up position.

6. SET ENGINE THROTTLE TO 1/2 throttle.

7. TURN IGNITION KEY to "START" position and release to "RUN" as soon as engine starts. NOTE: Prolonged cranking will damage starter motor and shorten the battery life.
8. ADJUST ENGINE THROTTLE AND CHOKE for desired engine smoothness and speed. NOTE: When mowing, always run engine at full throttle.
9. RELEASE PARKING BRAKE. Push brake lever downward to release.

⚠ CAUTION

If the operator is inexperienced with the zero turning radius lever steering/speed control, he/she should follow these recommendations: Disengage the mower blades. Go very slowly until thoroughly familiar with the machine. Keep away from fences, buildings, and other obstructions. While becoming familiar with the machine, move the Control Levers smoothly and slowly. Practice until operation is smooth and efficient.

10. TO DRIVE: Adjust seat forward or backward for operator comfort. Move the Control Levers to the "IN" position. Move Control Levers forward to move forward. Move levers slowly forward to increase speed. To reverse direction, move the Control Levers slowly rearward. To turn on a zero radius axis, go slowly and pull one Control Lever back and push the other Control Lever forward, depending on which direction you wish to turn.

⚠ WARNING

**AVOID SERIOUS INJURY OR DEATH:
DO NOT MOVE STEERING LEVERS FROM FORWARD TO REVERSE OR REVERSE TO FORWARD POSITION RAPIDLY. A SUDDEN CHANGE IN DIRECTION MAY CAUSE LOSS OF CONTROL AND/OR DAMAGE TO EQUIPMENT. FOR SMOOTH, SAFE OPERATION, MOVE THE CONTROL LEVERS IN A GENTLE, SLOW MOTION, ESPECIALLY ON GRADES.**

11. BRAKING: To brake mower, gently move Control Levers in the direction opposite to travel. If the parking brake is engaged with the Control Levers in the "IN" position the engine will stop.
12. CUTTING HEIGHT ADJUSTMENT:
 1. Disengage the blades.
 2. Stop engine and move the control levers to the neutral position and engage the parking brake.
 3. Depress the deck lift foot pedal raising the deck to the transport position and place the pedal in the locked position.
 4. Insert height adjustment pin into the hole corresponding to the desired cutting height. See decal on the top of the deck lift plate.
 5. Depress the deck lift pedal and lower the deck to the selected mowing height.
 6. To transport, depress the lift foot pedal and lock in position, then move the height adjustment pin to the 4-1/2" position.

ANTI-SCALP ROLLER ADJUSTMENT:

1. Stop engine and move the control levers to the neutral position and engage the parking brake.
2. Disengage the blades.
3. The Anti-Scalp deck rollers are adjustable up and down to provide improved deck flotation and scalping protection at various cutting heights. They are not intended to ride continuously on the ground. Rollers should always be 1" - 2" below blade level, but no closer than 1/2" from ground. DO NOT adjust rollers to support deck.
4. Front Anti-Scalp rollers brackets are removable.

CUTTING HEIGHT ADJUSTMENT



13. ENGAGE MOWER BLADES by pulling up on the PTO clutch switch. The engine will not start if the PTO switch is engaged. If the engine is running while the PTO clutch is engaged and the operator leaves the seat, the engine will stop.

⚠ WARNING

Use EXTREME caution when mowing and/or turning on slopes as loss of traction and/or tip-over could occur. Drive slower on slopes. DO NOT mow slopes greater than 15 degrees. Watch for ditches, holes, rocks, dips and rises, which change the operating angle. Keep away from drop-offs and steep banks. Avoid sudden starts when mowing uphill - mower may tip backwards. Loss of traction may occur going downhill - weight transfer to the front wheels may cause drive wheels to slip and cause loss of braking. DO NOT mow slopes when grass is wet - slippery conditions affect steering and reduce traction and braking. The operator is responsible for safe OPERATION ON SLOPES.

14. TO STOP:

- A. Slow engine speed with throttle to slowest position
- B. Disengage the mower blade clutch by moving the PTO clutch switch to the "OFF" position.
- C. Move Control Levers to neutral position and then to the "OUT" position.
- D. Set the parking brake.
- E. Turn ignition key to "OFF" position.

- F. Remove the key and wait for all movement and all sound to cease before dismounting.

⚠ WARNING

AVOID SERIOUS INJURIES TO OTHERS: ALWAYS REMOVE THE KEY FROM THE IGNITION SWITCH WHENEVER THE MOWER IS UNATTENDED TO PREVENT CHILDREN OR UNAUTHORIZED PERSONS FROM STARTING THE ENGINE.

15. **HYDRAULIC COMPONENTS BYPASS-TO MOVE THE TRACTOR WITHOUT POWER:** The bypass levers are located on the rear of the engine plate. **NOTE: Exhaust muffler can be extremely hot. Use extreme caution when engaging or disengaging bypass levers to prevent severe burns. Pull both the RH & LH levers to the rear and lock out in the keyway slot to disengage for freewheeling. Reverse this procedure for operation.**

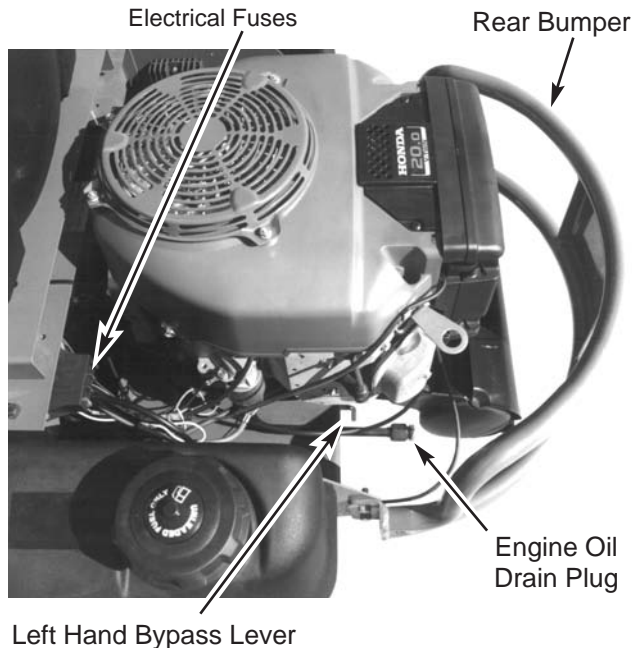

NOTE: To move the tractor without power, the pumps must be unlocked and in the free wheel position. Failure to do so could possibly damage the hydraulic components. Never pull at more than 2 MPH.

16. **FUEL SHUT-OFF VALVE:** Located on the front panel below the operator is the fuel directional valve. This valve has three positions for operations and each position is made in 1/4 turn increments. This directional valve has a shut off position and can be used when the machine will not be used for a few days or when the unit is transported to and from a work site.

| <u>Fuel Flow</u> | <u>Valve Position</u> |
|------------------|-----------------------|
| Off | Down |
| Right Tank | Right |
| Left Tank | Left |

MOWING RECOMMENDATIONS

1. Keep mower blades sharp.
2. Make sure deck and discharge chute are clean.

⚠ WARNING

TO AVOID SERIOUS INJURY FROM BLADE CONTACT, POWER MUST BE OFF TO CLEAN DISCHARGE CHUTE

⚠ DANGER

KEEP HANDS AND FEET AWAY FROM UNDERNEATH MOWER TO AVOID SERIOUS INJURY OR DEATH.

⚠ WARNING

ROTARY MOWERS CAN DISCHARGE OBJECTS AT HIGH SPEEDS. TO AVOID SERIOUS INJURIES OR DEATH:

- OPERATE ONLY WITH SIDE BANDS IN GOOD REPAIR AND CHUTE OR GRASS CATCHER ATTACHMENT INSTALLED.
- KEEP CHILDREN, PETS, AND BYSTANDERS AWAY FROM THE WORK AREA.
- DO NOT OPERATE MOWER IN THE VICINITY OF OTHER PERSONS.
- DISCHARGE AWAY FROM BUILDINGS, WALLS OR OTHER STRUCTURES.

Fuel Shut-Off Valve Handle Parking Brake Handle



SECTION III MAINTENANCE



BEFORE PERFORMING ANY MAINTENANCE, TURN OFF ENGINE, REMOVE KEY AND DISCONNECT SPARK PLUGS. USE EXTREME CARE WHEN WORKING ON MACHINERY. DO NOT WEAR WATCH OR JEWELRY. DO NOT WEAR LOOSE FITTING CLOTHES, AND OBSERVE ALL COMMON SAFETY PRACTICES WITH TOOLS.

IMPORTANT:

BEFORE PERFORMING ANY SERVICE, MAINTENANCE OR REPAIR ON THE ENGINE, REFER TO THE RESPECTIVE ENGINE MANUFACTURERS' MANUAL FOR SPECIFIC INFORMATION CONCERNING YOUR PARTICULAR BRAND OF ENGINE.

MAINTENANCE SCHEDULE

SERVICE

WHEN

| | |
|--|---|
| Check crankcase oil level _____ | before each use |
| Check air intake screen _____ | after each use |
| Clean grass from under deck _____ | after each use |
| Check tire pressure _____ | every 10 hours |
| Sharpen mower blades _____ | every 10 hours |
| Clean air filter element _____ | every 8 hours |
| Check 20W50 motor oil in hydrostatic system _____ | every 100 hours |
| Check drive belts _____ | every 50 hours (20 hr break-in) |
| Grease blade spindles _____ | every 50 hours |
| Change engine crankcase oil _____ | (Refer to engine mfg. manual) |
| Change engine oil filter _____ | (Refer to engine mfg. manual) |
| Change hydrostatic oil filter (See your Bush Hog Dealer) Important: Substitution of an improper filter will cause hydrostatic failure which will not be covered under warranty _____ | every 200 hours (50 hrs break-in) |
| Replace air filter element _____ | (Refer to engine mfg. manual) |
| Check spark plugs _____ | (Refer to engine mfg. manual) |
| Service battery _____ | annually or 500 hours |
| Change hydrostatic oil _____ | every 200 hours |

Perform these maintenance procedures more frequently under extremely dusty, dirty conditions.

Replace decals when illegible. Write parts dept. for free replacement.

1. ENGINE:

For complete maintenance and operating information for your engine, please refer to your engine operating and maintenance instructions furnished by the engine manufacturer and included in your Zero Turn mower information packet.

NOTE

Air intake screen must be kept clean. If plugged, engine may be seriously damaged by over heating.

The hour meter includes a feature to remind the owner to change engine oil and oil filter at recommended hour intervals. The service intervals are indicated by the respective flashing "SVC" lights on the display. Service indicators last for (2) hours starting (1) hour before and ending (1) hour after the interval.

The left "SVC" light flashes at first interval of (5) hours, second interval (25) hours, then every (25) hours thereafter. The right "SVC" light flashes at every (100) hour interval. Refer to your engine manual to determine which "SVC" indicator coincides with their service recommendation.

2. BATTERY:

⚠ WARNING

AVOID SERIOUS INJURY OR DEATH:

- **THE BATTERY CONTAINS SULFURIC ACID. AVOID CONTACT WITH SKIN, EYES OR CLOTHING. EYES - FLUSH WITH WATER AND GET PROMPT MEDICAL ATTENTION. ANTIDOTE: INTERNAL - DRINK LARGE QUANTITIES OF WATER OR MILK. FOLLOW WITH MILK OF MAGNESIA, BEATEN EGG OR VEGETABLE OIL. CALL A PHYSICIAN IMMEDIATELY.**
- **BATTERIES PRODUCE EXPLOSIVE GASES. KEEP SPARKS, FLAMES AND SMOKING MATERIALS AWAY. VENTILATE WHEN CHARGING IN AN ENCLOSED SPACE. WEAR EYE PROTECTION**

When taking the battery out of the mower for servicing, make sure to reconnect the cables to the battery exactly as they were prior to removal.

Keep the battery clean. Remove the corrosion around the battery terminals by applying a solution of one part baking soda to four parts water. Coat all exposed terminal surfaces with a light layer of grease or petroleum jell to prevent corrosion.

NOTE

At temperatures below 32 degrees F (0 deg C) the full charge state must be maintained to prevent cell electrolyte from freezing and causing permanent battery damage.

3. TIRES:

Correct tire pressure is essential for efficient operation of the mower. Incorrect inflation pressure will affect riding comfort, traction and cutting quality. Check tire air pressure periodically with a low pressure gauge.. Inflate tires to the pressure listed:

TIRE PRESSURE: Front & Rear Tires 9 -12 psi

Lug nuts should be checked regularly for tightness. Torque lug nuts to 59 ft. / lbs.

4. MOWER BLADES:

Check sharpness of mower blades after every 10 hours of operation. To sharpen blades proceed as follows:

⚠ WARNING

WHEN IT IS NECESSARY TO RAISE THE DECK OR MOWER FOR SERVICE OR MAINTENANCE, TO AVOID SERIOUS INJURY OR DEATH, STOP ENGINE, SET PARKING BRAKE, REMOVE IGNITION KEY AND SPARK PLUG WIRES AND SECURELY SUPPORT THE DECK OR MOWER BEFORE WORKING UNDERNEATH.

- A. Lift deck and secure in raised position.
- B. Remove bolt, cup washer, and blade from shaft.
- C. Blades should be discarded when worn excessively. See sketch.



D. Sharpen blade with a hand file, electric grinder or blade sharpener. Wear gloves and eye protection when sharpening. Grind blade at original bevel.

E. Check balance of blade by positioning the blade on a nail or blade balance pedestal. Grind the blade on the end that is heavier until both sides balance.

F. Install blades with the concave side of the cup washer against blade. Be sure blades are installed with uplifts and cutting edges in the proper directions.

Tighten retaining bolt to 76 ft./lbs.

⚠ WARNING

WHEN IT IS NECESSARY TO RAISE THE DECK OR MOWER FOR SERVICE OR MAINTENANCE, TO AVOID SERIOUS INJURY OR DEATH, STOP ENGINE, SET PARKING BRAKE, REMOVE IGNITION KEY AND SPARK PLUG WIRES AND SECURELY SUPPORT THE DECK OR MOWER BEFORE WORKING UNDERNEATH.

5. CLEANING GRASS BUILD UP UNDER DECK

Depress the deck lift foot pedal and lock in position, then move the height adjustment pin to the 4-1/2" position.

Lift the front of the unit and support unit securely.

Clean out any grass build up from underside of deck and in deck discharge chute.

NEUTRAL ADJUSTMENT

1. Stop engine and remove ignition key.
2. Tilt seat forward.
3. Move the control lever rearward and release the control lever. This control lever should return to a position where the control lever can be swung outward and lock in the neutral outward position. This setting is fixed and not adjustable. If the handles do not return to neutral, contact a servicing dealer.

MOTION CONTROL NEUTRAL ADJUSTMENT

The steering has been factory adjusted to eliminate creeping when the control levers are in neutral position. However, should the mower begin to creep, adjustments can be made as outlined below. Before considering any adjustment, check the tire pressure and make certain hydraulic system oil is at operating temperature. Unequal tire pressure can cause the mower to drift to one side (see recommended tire pressure).

1. Raise the drive wheels of the zero turn off the ground. Safely block the frame in this position so it is secure. This adjustment must be made with the drive wheels free to turn.
2. Remove the electrical connection from the seat switch and **temporarily** install a jumper wire across the terminals of the wiring harness.
3. Loosen the jamnuts on the vertical turnbuckles, which connect the lever control arms to the hydrostatic component control arms. Note: The nuts at the top of the turnbuckles have left-handed threads.
4. Start the engine. Release the parking brake and throttle up the engine to full throttle.
5. Observe which direction the wheels are rotating. If the wheels are rotating forward, rotate the vertical turnbuckle clockwise to shorten the steering control linkage until the wheel(s) come to a stop. Repeat for the opposite side if necessary. (Note: The right hand linkage controls the right hydrostatic component and the left handle controls the left hydrostatic component)
6. If the wheels are rotating in reverse, then rotate the vertical turnbuckle counter-clockwise to lengthen the steering control linkage until the wheel(s) come to a stop. Repeat for the opposite side if necessary.

7. When both wheels remain in neutral, tighten the jam nuts to lock the vertical turnbuckle in place.
8. Test again by moving the control levers forward and backward before returning them to the neutral position. If the tires are in neutral, the unit is now ready for operation.
9. Shut the unit off. Remove the jumper wire from the wiring harness and replace the connectors into the seat switch. Never operate the mower unless all safety switches are operating properly.

CONTROL LEVER ADJUSTMENT

The control levers can be adjusted for operator comfort. Loosen the hex head cap screws that attach the upper control lever to the lower control lever. The upper control lever can be pivoted to fit the operator's personal preference. The control levers should be adjusted so they align with each other when in the neutral position. The upper levers can also be adjusted vertically for operator comfort. Note: The upper control levers were shipped in the highest position from the factory to allow for optional seats with armrests. If your unit does not have seat armrests, and you would prefer a lower height, then remove the hex head screws from each upper handle and lower to the lower position. Reinstall hardware and securely tighten.

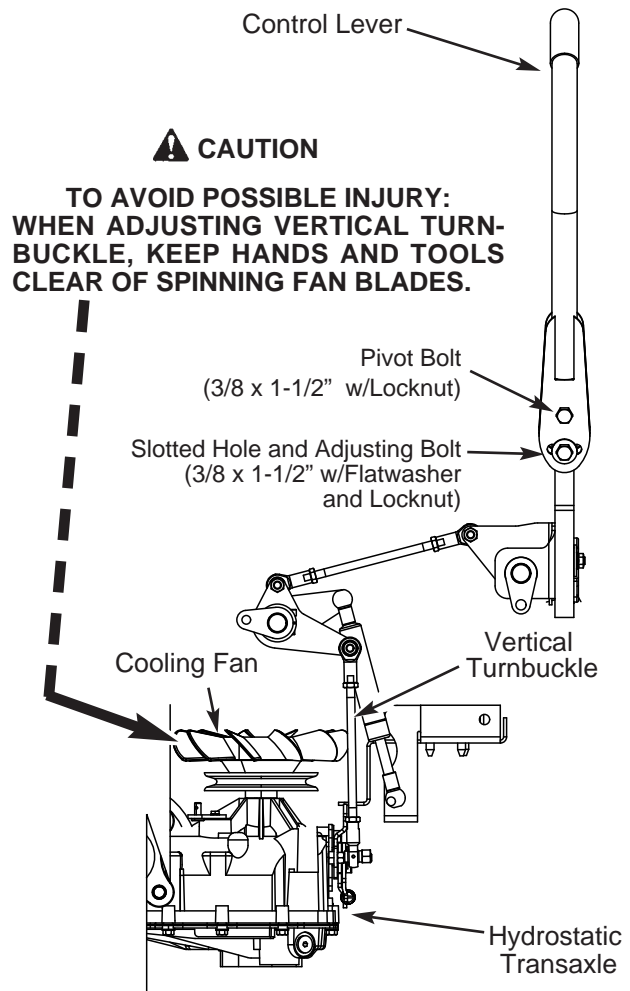

LEVELING THE DECK AND SETTING THE COUNTERBALANCE SPRING TENSION

1. Set all tire pressures to the correct specifications.
2. Rest machine on a level slab of concrete.
3. Depress the deck lift pedal to raise the deck to the full lift height position and move the height adjust pin to the 4.5" position.
4. Take all the force off the two deck lift springs by loosening the nut at the front of each spring.
5. Place a level on the deck, from front to rear. If the level is too short to reach all the way from front to rear, lay a straight edge on the deck first, then place the level on the straight edge.
6. Lay a .12" spacer beneath the front level. this will automatically set the rear of the deck higher than the front.
7. Adjust the nuts at the rear trunnion forward to raise the rear of the deck (Shown below) until the level's bubble is centered. Repeat for the other side.
8. Check to verify the deck is leveled side-to-side. To do this, lay a 2" x 4" x 30" piece of wood under each side of the deck and lower the deck to rest freely on the top of these boards. Inspect the (4) lift chains to see if tension is on each of them. If any of the chains appear slack, loosen the cam bushing bolt just enough to allow the cam bushing to be turned to remove the slack from the chain. Tighten the cam bushing bolt to 76 ft.lbs.
9. Raise the deck up to the transport position and lock in place.
10. Remove the 2" x 4"s from under the deck.
11. Tighten each of the counterbalance spring nuts until springs are to the following lengths.
44" Deck - Spring length of 16.5"
52" Deck - Spring length of 16.0"
The springs may be tightened or loosened from this point according to personal preference.

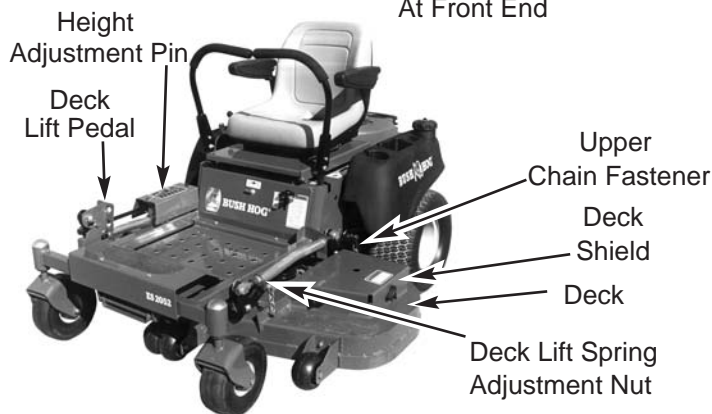
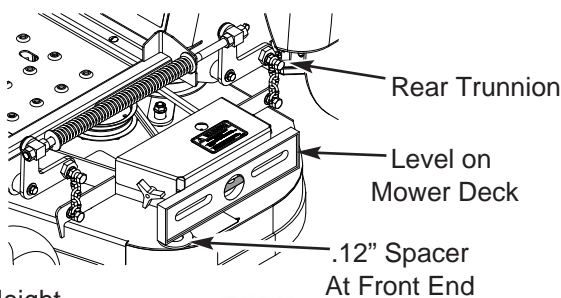

DECK BELT ADJUSTMENT

Belt adjustment should be checked every (50) hours of operation to get maximum life and cutting performance. Belt tension is adjusted by increasing or decreasing the length of the spring on the movable idler by adjusting the eye bolt length (Shown below). For correct belt tension, adjust the spring length to 6-7/8" for the 44" deck and 7-1/2" for the 52" deck.

DECK BELT REPLACEMENT (NOTE: Use only genuine Bush Hog replacement parts)

1. Remove the R.H. and L.H. deck shield assemblies (Fig.).
2. Relieve the spring tension by loosening the two 5/16" hex nuts on the spring adjustment eye bolt.
3. Remove the old belt.
4. Install the new belt being sure the belt is properly routed and positioned in all sheave grooves.
5. Adjust tension on the belt by adjusting the length of the spring on the idler (See Deck Belt Adjustment section).
6. Replace the deck shield assemblies.

DECK BELT DIAGRAM

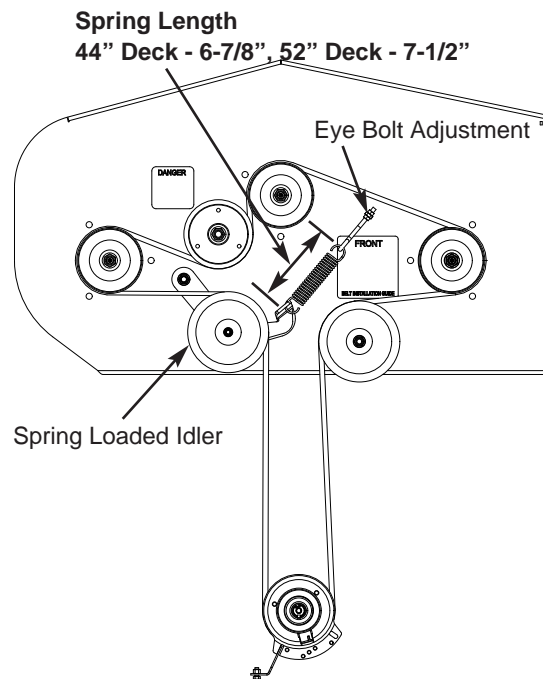

⚠ WARNING

TO AVOID SERIOUS BURN INJURIES:

- ALLOW ENGINE, OIL AND HYDRAULIC FLUIDS TO COOL BEFORE SERVICING TRANSMISSION OR ENGINE SYSTEM

⚠ CAUTION

TO AVOID CLEANING SOLVENT FIRES:

- AVOID USING FLAMMABLE SOLVENTS.
- AVOID AREAS WITH IGNITION SOURCES WHEN USING FLAMMABLE SOLVENTS.

HYDROSTATIC TRANSAXLE BELT TENSION ADJUSTMENT

1. Stop engine and remove key.
2. The hydrostatic transaxle belt tension is adjusted through a spring loaded idler pulley.
3. The tension can be adjusted by loosening the (2) hex nuts on the end of the spring support bolt and turning them until the spring length is 3-7/16" (Shown at right). Tighten the jam nuts together.

HYDROSTATIC TRANSAXLE (MOTION DRIVE) BELT REPLACEMENT

1. Stop engine and remove key.
2. Relieve the belt tension on the drive belt (See Belt Adjustment section) and drop the belt from the electric clutch deck pulley at the rear of the unit.
3. Remove the electric clutch anti-rotation bracket at the rear of the unit.
4. Relieve the spring tension on the motion drive belt by loosening the (2) hex jam nuts on the end of the spring support bolt.
5. Remove the old belt.
6. Install the new belt being sure the belt is properly routed and positioned in all sheave grooves.
7. Adjust tension on the belt by adjusting the length of the spring on the idler (See Belt Adjustment section).
8. Reinstall the electric clutch anti-rotation bracket, the deck belt and re-tension the deck belt (See Deck Belt Adjustment section).

WARNING

HIGH PRESSURE HYDRAULIC FLUID LEAKS CAN PENETRATE SKIN CAUSING SERIOUS INJURY AND GANGRENE.

INJECTED FLUID MUST BE SURGICALLY REMOVED WITHIN A FEW HOURS BY A DOCTOR FAMILIAR WITH THIS TYPE OF INJURY.

TO AVOID SERIOUS INJURY FROM PRESSURE LEAKS:

- USE CARDBOARD AND NOT HANDS TO SEARCH FOR LEAKS.
- RELIEVE HYDRAULIC PRESSURE BEFORE WORKING ON SYSTEM.
- CHECK HYDRAULIC HOSES, LINES, AND CONNECTIONS FOR TIGHTNESS AND GOOD CONDITION BEFORE APPLYING SYSTEM PRESSURE.

START-UP MAINTENANCE

Bush Hog recommends the use of SAE 20W50 motor oil in the hydrostatic reservoir.

HYDROSTATIC TRANSAXLE MAINTENANCE

The hydrostatic transaxle units normally do not

HYDROSTATIC BELT DIAGRAM

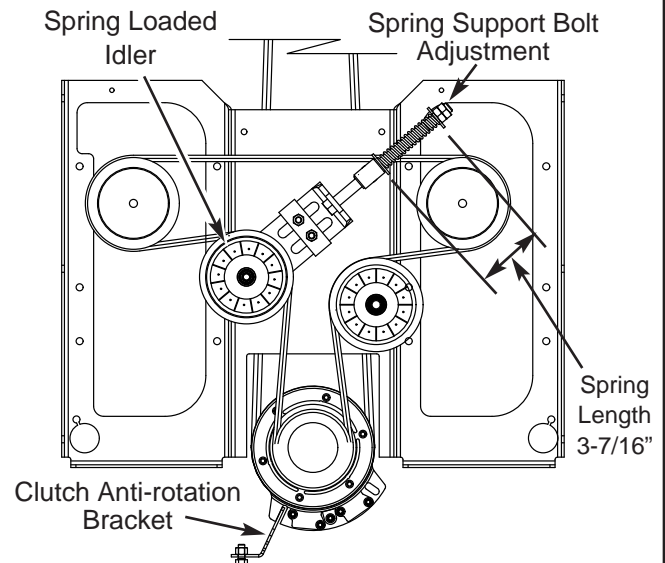

require regular fluid changes. The system filter should be changed after the first 50 hours of break-in, then every 200 hours thereafter. The fluid and filter should be changed and the system cleaned if the fluid becomes contaminated with foreign matter (water, dirt, etc.).

FLUID VOLUME AND LEVEL

Certain situations may require additional fluid to be added or even replaced. Refer to the Figure below for the proper fill port location. 79 fl. oz. is the correct amount of fluid to add to an empty transaxle.

The level of fluid in the transaxle may be checked by removing the plastic breather tube and inserting a clean, straight metal rod down through the fill port until it bottoms out. Remove the rod and the oil should extend approximately 4-1/4" up the rod.

IMPORTANT Do Not Overfill

If you overfill the transaxle while the unit is "cold", it may overflow as it reaches normal operating temperatures. The oil level should not be above the manufacturer's suggestions outlined in this manual. This will allow the space needed for the oil to expand as it warms up.

Recheck the fluid level once the unit has been operated for approximately one minute.

FLUID CHANGE

In the event of oil contamination or degradation, oil addition or change may alleviate certain performance problems. It is essential that the unit exterior be free of debris prior to fluid maintenance.

Remove the oil drain plug from the bottom of the unit to facilitate oil change. When reinstalling oil drain plug torque the plug to 180 - 240 in. lbs.

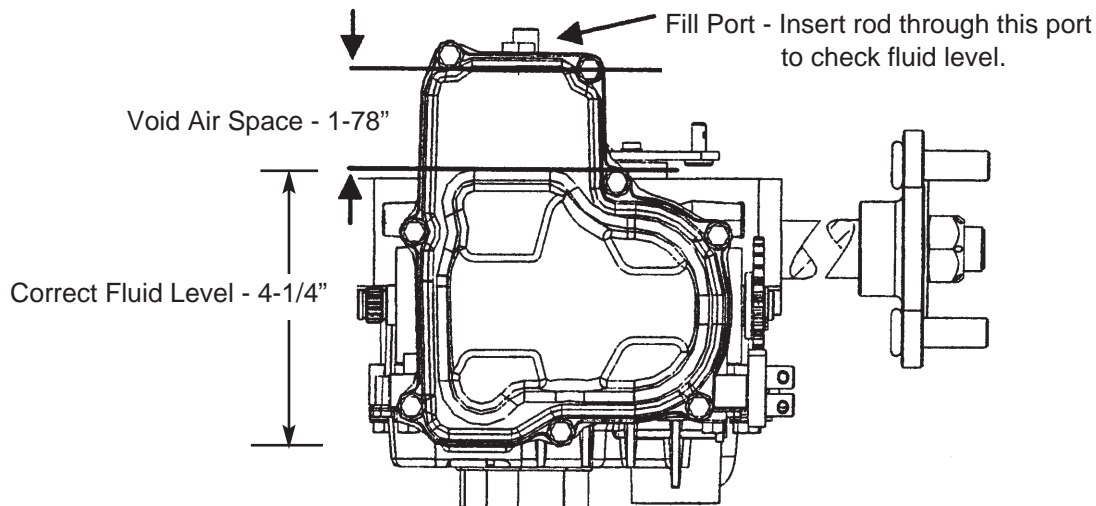

IMPORTANT

When tightening the filter insure proper torque value of 20 - 50 in. lbs. is applied. Filter is plastic. Excessive torque will damage filter.

Due to the effects air has on efficiency in the hydrostatic drive applications, it is critical that it be purged from the system.

These purge procedures should be implemented any time a hydrostatic system has been opened to facilitate maintenance or any additional oil has been added to the system.

Air creates inefficiency because its compression and expansion rate is higher than that of the oil normally approved for use in hydrostatic drive systems.

The resulting symptoms in hydrostatic systems may be:

1. Noisy operation.
2. Lack of power or drive after short term operation.
3. High operation temperature and excessive expansion of oil.

Before starting, make sure the transaxle/ transmission is at the proper oil level. If it is not, fill to the specifications outlined above.

PURGING PROCEDURES

The following procedure should be performed with the vehicle wheels off the ground, then repeated under normal operating conditions.

1. With the bypass valve open and the engine running, slowly move the directional control in both forward and reverse directions 5 or 6 times. As air is purged from the unit, the oil level will drop.
2. With the bypass valve closed and the engine running, slowly move the directional control in both forward and reverse directions (5 to 6 times). Check

the oil level, and add oil as required after stopping engine.

3. It may be necessary to repeat Steps 1 and 2 until all the air is completely purged from the system. When the transaxle moves forward and reverse at normal speed, purging is complete.

PARKING BRAKE ADJUSTMENT

The parking brake has been set correctly from the factory. Occasionally check the parking brakes and adjustment using the following method:

1. Position the control levers in the neutral position.
2. Disengage the hydrostatic transaxle by pulling out and locking the bypass levers.
3. Move the parking brake lever to the brake position.
4. The brake pawl should now be activated and engaging the hydrostatic components brake gear.
5. Move the parking brake lever down to disengage the brake. Standing behind the unit, the mower should be able to be pushed around freely.
6. If the brakes do not operate correctly, the cable must be adjusted. To adjust the brake cables, loosen the two locknuts on the spring end of the cables, just to the inside of each of the rear tires. Adjust the cables up or down the threaded adjustment until the brake pawl is fully engaging the brake gear when the brake is engaged and the spring is slightly extended and the brake pawl is fully disengaging the brake gear when the brake lever is disengaged.
7. Tighten the locknuts securely.

TROUBLESHOOTING CHECK LIST

1. ENGINE IDLES POORLY:

Carburetor maladjustment _____ readjust carburetor
Improper spark plug gap _____ check and re-gap plug

2. ENGINE BACKFIRES:

Carburetor maladjustment _____ readjust carburetor

3. ENGINE RUNS BUT POWER UNIT WON'T MOVE FORWARD

Drive belt loose or broken _____ re-tension or replace
Pump shift arm disconnected _____ reconnect
Pump bypass valves open _____ put in closed position
Hydrostatic oil filter plugged _____ replace filter
Bad transaxle _____ consult dealer

4. POWER UNIT LOSES POWER OR HYDROSTAT SYSTEM OVERHEATS

Hydrostatic transaxle oil too low _____ add oil
Hydrostatic transaxle damaged _____ consult dealer
Hydrostatic transaxle oil blowing oil out vent _____ overfilled or water contaminated

5. ENGINE STALLS WHEN BLADES ARE ENGAGED

Operator not on seat _____ sit on seat
Faulty interlock system _____ consult dealer
Bad blade spindle bearing _____ consult dealer
Deck drive belt not properly routed _____ reroute
Blades blocked by foreign material _____ clean under deck

•See engine manual for engine adjustments

ENGINE ELECTRICAL TROUBLE SHOOTING

1. ENGINE WILL NOT TURN OVER:

Dead battery
Bad ground connection
Bad terminal connection at battery
Wiring harness plugs are not attached properly at
the key switch or the PTO switch
Bad parking brake switch
Bad PTO switch

2. ENGINE WILL TURN OVER, BUT WILL NOT START:

A. If there is spark at the plug:

No fuel
Bad fuel solenoid in engine

B. If there is no spark at the plug:

Make sure safety interlock system is sequenced:
PTO switch is off
Control levers in neutral position
Parking brake is on
Operator in seat
Check safety interlock switches:
Seat switch
Neutral switch
Bad ignition module on engine

SECTION IV ASSEMBLY

MOUNTING SEAT

Unbolt and remove either the standard seat, standard seat w/armrests or the suspension seat from the shipping container. Retain the fasteners for use in mounting the seat. Align the four 5/16" holes in the seat frame with the appropriate slots or holes in the seat mounting plate as shown below. Attach the seat using the hardware removed previously, and from the parts bag (4 - 5/16" - 18 x 3/4" capscrews, 4 - 5/16" flatwashers, and 4 - 5/16" split lock washers for the standard seats and the 5/16" - flanged locknuts (4) for the full suspension seat).

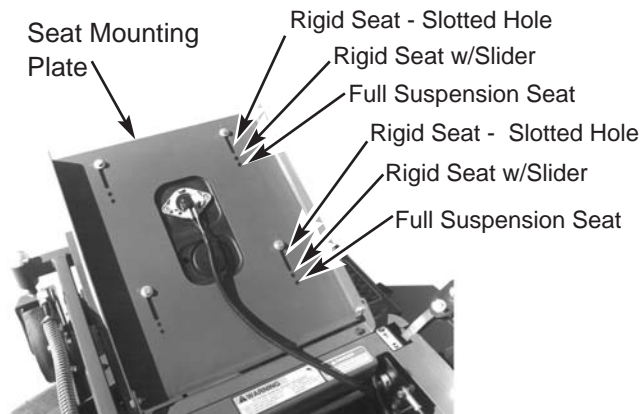

CONTROL LEVERS

Fold control levers forward into position and fasten into place as shown below using fasteners provided. Slotted hole at bottom of bracket allows position adjustment of the levers.



Slotted Hole and Adjusting Bolt
(3/8 x 1-1/2" w/Flatwasher and Locknut)

BATTERY

Attach the positive lead to the battery.

Additional wire tie straps are shipped to secure the wiring harness as needed.

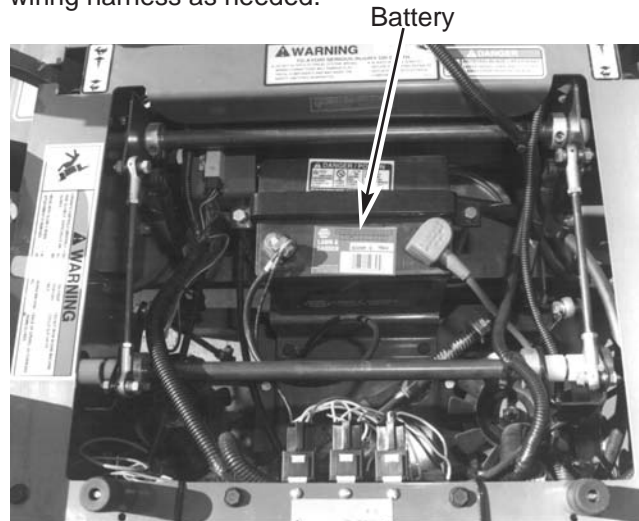

DISCHARGE CHUTE

The discharge chute for the 52" deck is shipped separate from the deck. Place the chute into position and fasten with the fasteners provided.

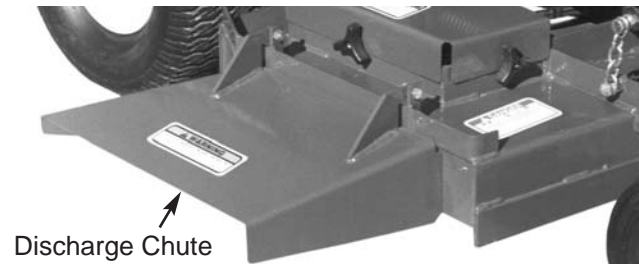

REAR BUMPER

The rear bumper is shipped separate from the ZT frame. Position the bumper into place (as shown on page 12) and fasten using (4) 3/8" x 3/4". Gr. 5 bolts and locknuts. **NOTE:** Use the top holes with either of the Briggs & Stratton or Honda engines and the bottom holes with the Kohler engines.

ITEMS TO CHECK:

- Check oil level in the engine (see engine manual)
- Check tightness of all fasteners, including bolts, lug nuts, and setscrews.
- Check tire pressure.

Pivot Bolt
(3/8 x 1-1/2" w/Locknut)

SAFETY DECALS

To promote safe operation, Bush Hog supplies safety decals on all products manufactured. Because damage can occur to safety decals either through shipment, use or reconditioning, Bush Hog will, upon request, provide safety decals for any of our products in the field at no charge. Contact your authorized Bush Hog dealer for more information.



83056



94132



50043277



50012615



⚠️ WARNING

- OPERATE CONTROLS SMOOTHLY AND SLOWLY, ESPECIALLY ON SLOPES.
- DO NOT OPERATE ON STEEP SLOPES: SEE OPERATORS MANUAL FOR DETAILS.
- DO NOT MOW WHERE MACHINE COULD SLIP OR TIP.
- MOVE VERY SLOWLY WHEN ATTACHMENT IS REMOVED.
- ALWAYS LOOK BEHIND MACHINE BEFORE BACKING.
- BACK UP SLOPES. GO FORWARD DOWN SLOPES.

50043278

50043278

⚠️ WARNING

TO AVOID SERIOUS INJURY OR DEATH

- READ OPERATORS MANUAL BEFORE OPERATING & FOLLOW ALL PRECAUTIONS. (CONTACT DEALER FOR MANUAL)
- LOWER IMPLEMENT, STOP ENGINE AND REMOVE KEY BEFORE DISMOUNTING.
- NO RIDERS. DO NOT OPERATE MOWER IN VICINITY OF OTHER PERSONS.
- ALLOW NO CHILDREN OR UNQUALIFIED PERSONS TO OPERATE EQUIPMENT.
- CLEAR MOWING AREA OF DEBRIS.
- KEEP SHIELDS AND GUARDS IN PLACE. KEEP CLEAR OF DRIVES AND BELTS
- SECURELY SUPPORT MOWER & REMOVE KEY BEFORE WORKING UNDERNEATH.
- KNOW HOW TO STOP TRACTOR AND EQUIPMENT QUICKLY IN AN EMERGENCY.
- BE CAREFUL ON UNEVEN TERRAIN DECREASE SPEED WHEN TURNING.

50043279

50043279

⚠️ CAUTION

- ★ SHUT OFF ENGINE BEFORE REFUELING
- ★ NEVER FILL FUEL TANK INDOORS OR WHEN ENGINE IS HOT.
- ★ WIPE UP ALL SPILLED FUEL BEFORE STARTING ENGINE.
- ★ DO NOT SMOKE WHILE REFUELING.

94131

94131

⚠️ DANGER



**KEEP AWAY – ROTATING BLADES
SERIOUS INJURY OR DEATH CAN RESULT FROM
THROWN OBJECTS OR BLADE CONTACT**

- * DO NOT STAND ON OR NEAR MACHINE WHEN IN OPERATION.
- * KEEP HANDS AND FEET AWAY FROM UNDERNEATH CUTTER TO AVOID SERIOUS INJURY.
- * NEVER OPERATE WITHOUT DISCHARGE CHUTE OR VACUUM BLOWER ASSEMBLY IN PLACE.

50043280

50043280

TORQUE SPECIFICATIONS

Proper torque for American fasteners used on Bush Hog equipment.
Recommended Torque in Foot Pounds (Newton Meters).*

AMERICAN

Bolt Head Markings

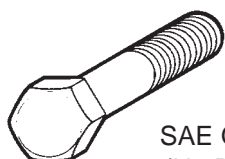

SAE Grade 2
(No Dashes)

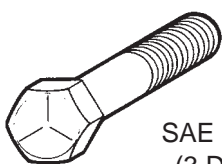

SAE Grade 5
(3 Dashes)

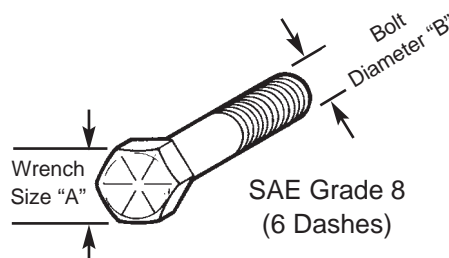

SAE Grade 8
(6 Dashes)

| WRENCH SIZE (IN.) "A" | BOLT DIAMETER (IN.) "B" AND THREAD SIZE | SAE GRADE 2 | SAE GRADE 5 | SAE GRADE 8 |
|-----------------------|---|-------------|-------------|-------------|
| 7/16 | 1/4 - 20 UNC | 6 (7) | 8 (11) | 12 (16) |
| 7/16 | 1/4 - 28 UNF | 6 (8) | 10 (13) | 14 (18) |
| 1/2 | 5/16 - 18 UNC | 11 (15) | 17 (23) | 25 (33) |
| 1/2 | 5/16 - 24 UNF | 13 (17) | 19 (26) | 27 (37) |
| 9/16 | 3/8 - 16 UNC | 20 (27) | 31 (42) | 44 (60) |
| 9/16 | 3/8 - 24 UNF | 23 (31) | 35 (47) | 49 (66) |
| 5/8 | 7/16 - 14 UNC | 32 (43) | 49 (66) | 70 (95) |
| 5/8 | 7/16 - 20 UNF | 36 (49) | 55 (75) | 78 (106) |
| 3/4 | 1/2 - 13 UNC | 49 (66) | 76 (103) | 106 (144) |
| 3/4 | 1/2 - 20 UNF | 55 (75) | 85 (115) | 120 (163) |
| 7/8 | 9/16 - 12 UNC | 70 (95) | 109 (148) | 153 (207) |
| 7/8 | 9/16 - 18 UNF | 79 (107) | 122 (165) | 172 (233) |
| 15/16 | 5/8 - 11 UNC | 97 (131) | 150 (203) | 212 (287) |
| 15/16 | 5/8 - 18 UNF | 110 (149) | 170 (230) | 240 (325) |
| 1-1/8 | 3/4 - 10 UNC | 144 (195) | 266 (360) | 376 (509) |
| 1-1/8 | 3/4 - 16 UNF | 192 (260) | 297 (402) | 420 (569) |
| 1-5/16 | 7/8 - 9 UNC | 166 (225) | 430 (583) | 606 (821) |
| 1-5/16 | 7/8 - 14 UNF | 184 (249) | 474 (642) | 668 (905) |
| 1-1/2 | 1 - 8 UNC | 250 (339) | 644 (873) | 909 (1232) |
| 1-1/2 | 1 - 12 UNF | 274 (371) | 705 (955) | 995 (1348) |
| 1-1/2 | 1 - 14 UNF | 280 (379) | 721 (977) | 1019 (1381) |
| 1-11/16 | 1-1/8 - 7 UNC | 354 (480) | 795 (1077) | 1288(1745) |
| 1-11/16 | 1-1/8 - 12 UNF | 397 (538) | 890 (1206) | 1444 (1957) |
| 1-7/8 | 1-1/4 - 7 UNC | 500 (678) | 1120 (1518) | 1817 (2462) |
| 1-7/8 | 1-1/4 - 12 UNF | 553 (749) | 1241 (1682) | 2013 (2728) |
| 2-1/16 | 1-3/8 - 6 UNC | 655 (887) | 1470 (1992) | 2382 (3228) |
| 2-1/16 | 1-3/8 - 12 UNF | 746 (1011) | 1672 (2266) | 2712 (3675) |
| 2-1/4 | 1-1/2 - 6 UNC | 870 (1179) | 1950 (2642) | 3161 (4283) |
| 2-1/4 | 1-1/2 - 12 UNF | 979 (1327) | 2194 (2973) | 3557 (4820) |

METRIC

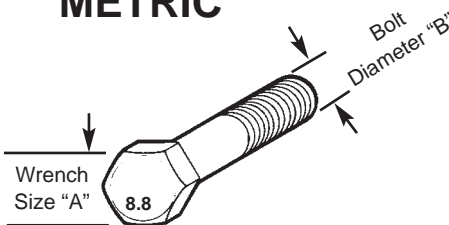

Numbers appearing on bolt heads indicate ASTM class.

Proper torque for metric fasteners used on Bush Hog equipment.
Recommended torque in foot pounds (newton Meters).*

| WRENCH SIZE (mm) "A" | BOLT DIA. (mm) "B" | ASTM 4.6 | ASTM 8.8 | ASTM 9.8 | ASTM 10.9 |
|----------------------|--------------------|-----------|-------------|-----------|-------------|
| 8 | 5 | 1.8 (2.4) | | 5.1 (6.9) | 6.5 (8.8) |
| 10 | 6 | 3 (4) | | 8.7 (12) | 11.1 (15) |
| 13 | 8 | 7.3 (10) | | 21.1 (29) | 27 (37) |
| 16 | 10 | 14.5 (20) | | 42 (57) | 53 (72) |
| 18 | 12 | 25 (34) | 74 (100) | 73 (99) | 93 (126) |
| 21 | 14 | 40 (54) | 118 (160) | 116 (157) | 148 (201) |
| 24 | 16 | 62 (84) | 167 (226) | 181 (245) | 230 (312) |
| 30 | 20 | 122 (165) | 325 (440) | | 449 (608) |
| 33 | 22 | | 443 (600) | | 611 (828) |
| 36 | 24 | 211 (286) | 563 (763) | | 778 (1054) |
| 41 | 27 | | 821 (1112) | | 1138 (1542) |
| 46 | 30 | 418 (566) | 1119 (1516) | | 1547 (2096) |

*Use 75% of the specified torque value for plated fasteners. Use 85% of the specified torque values for lubricated fasteners.



BUSH HOG[®]
Performance You Can Count OnSM

P.O. Box 1039 • Selma, AL 36702-1039
Telephone (334) 874-2700 • www.bushhog.com