

**BUSH HOG®**

**RTC50G**

**ROTARY TILLER**

Revised 08/20

MATERIAL HANDLING REPAIR PARTS MANUAL

# PARTS MANUAL

## SECTION 30



**BUSH HOG®**

2501 Griffin Ave.  
Selma, AL 36703  
Parts Ordering 1-800-304-2836  
www.bushhog.com

**ATENCIÓN!**

LEA EL INSTRUCTIVO

Si No Lee Ingles, Pida Ayuda a Alguien  
Que Si Lo Lea Para Que le Traduzca las  
Medidas de Seguridad.



**A** MEMBER OF THE  
ALAMO GROUP  
ALWAYS ON THE CUTTING EDGE®

© 2013 Alamo Group Inc.

## PARTS ORDERING GUIDE

The following instructions are offered to help eliminate needless delay and error in processing purchase orders for the equipment in this section.

1. The Parts Section is prepared in logical sequence and grouping of parts that belong to the basic machine featured in this manual. Part Numbers and Descriptions are given to help locate the parts and quantities required.
2. The Purchase Order must include the name and address of the person or organization ordering the parts, who should be charged, and if possible, the serial number of the machine for which the parts are ordered.
3. The Purchase Order must clearly list the quantity of each part, the complete and correct part number (be sure to include all periods), and the basic name of the part.
4. The Manufacturer reserves the right to substitute parts where applicable.
5. Some parts are unlisted items which are special production items not normally stocked and are subject to special handling. Request a quotation for such parts before sending a Purchase Order.
6. The Manufacturer reserves the right to change prices without prior notice.



For maximum safety and to guarantee optimum product reliability, always use genuine BUSH HOG Parts. The use of inferior replacement parts may cause premature or catastrophic failure which could result in serious injury or death. Direct any questions regarding parts to:

**BUSH HOG**  
**2501 Griffin Ave.**  
**Selma, AL 36703**  
**[www.bushhog.com](http://www.bushhog.com)**  
**Contact Us**  
**800-304-2836**



**BUSH HOG®**

# To the Owner/Operator/Dealer

All implements with moving parts are potentially hazardous. There is no substitute for a cautious, safe-minded operator who recognizes the potential hazards and follows reasonable safety practices. The manufacturer has designed this implement to be used with all its safety equipment properly attached to minimize the chance of accidents.

**BEFORE YOU START!** Read the safety messages on the implement and shown in your manual. Observe the rules of safety and common sense!

## **DANGER**

**FAILING TO FOLLOW SAFETY MESSAGES AND OPERATING INSTRUCTION CAN CAUSE SERIOUS BODILY INJURY OR EVEN DEATH TO OPERATOR AND OTHERS IN THE AREA.**

<p>1.</p> 	<p>2. NO RIDERS. NO CHILDREN OPERATORS</p> 	<p>3. USE SAFETY SHOES, HARD HAT, SAFETY GLASSES, SEAT BELTS, ROPS &amp; OPS.</p> 	<p>4. BLOCK UP SECURELY BEFORE WORKING UNDER.</p> 
---	--	--	---

1. Study and understand Operator's Manuals, Safety Decals, and Instructional Decals for tractor and implement to prevent misuse, abuse, and accidents. Practice before operating in a confined area or near passersby.

- Learn how to stop engine suddenly in an emergency. Be alert for passersby and especially children.

2. Allow no children on or near folding mower or tractor. Allow no riders on tractor or implement. Falling off may cause serious injury or death from being run over by tractor or mower or contact with rotating blades.

3. Operate only with tractor having Roll-Over Protective Structure (ROPS) and with seat belt securely fastened to prevent injury and possible death from falling off or tractor overturn.

- Personal Protective Equipment such as Hard Hat, Safety Glasses, Safety Shoes, & Ear Plugs are recommended.

4. Block up or support raised machine and all lifted components securely before putting hands or feet under or working underneath any lifted component to prevent crushing injury or death from sudden dropping or inadvertent operation of controls. Make certain area is clear before lowering or folding.

5. Before transporting, put Lift Lever in detent or full-lift position. Install Transport Safety Devices securely on folding mowers. Put Booms securely in Transport Rest.

- Folding and Boom Mowers have raised center of gravity. Slow down when turning and on hillsides.

6. Make certain that SMV sign, warning lights, and reflectors are clearly visible. Follow local traffic codes.

7. Never operate with Cutting Head or Folding Section raised if passersby, bystanders, or traffic are in the area to reduce possibility of injury or death from objects thrown by Blades under Guards or mower structure.

8. Before dismounting, secure implement in transport position or lower to ground.

- Put tractor in park position or set brake, disengage PTO, stop engine, remove key, and wait until noise of rotation has ceased to prevent crushing by entanglement in rotating parts which could cause injury or death.
- Never mount or dismount a moving vehicle. Crushing from rollover may cause serious injury or death.

<p>5. TRANSPORT SAFELY, LOCK UP.</p> 	<p>6. USE SMV, LIGHTS, &amp; REFLECTORS.</p> 	<p>7. DO NOT OPERATE WITH CUTTER OR WING RAISED</p> 	<p>8. DO NOT MOUNT OR DISMOUNT WHILE MOVING.</p> 
--	--	--	--

02967827

## WARRANTY INFORMATION:

Read and understand the complete Warranty Statement found in this Manual. Fill out the Warranty Registration Form in full and return it to within 30 Days. Make certain the Serial Number of the Machine is recorded on the Warranty Card and on the Warranty Form that you retain.

# LIMITED WARRANTY



Bush Hog warrants to the original purchaser of any new Bush Hog equipment, purchased from an authorized Bush Hog dealer, that the equipment be free from defects in material and workmanship for a period of one (1) year for non-commercial, state and municipalities' use and ninety (90) days for commercial use from date of retail sale. The obligation of Bush Hog to the purchaser under this warranty is limited to the repair or replacement of defective parts.

Replacement or repair parts installed in the equipment covered by this limited warranty are warranted for ninety (90) days from the date of purchase of such part or to the expiration of the applicable new equipment warranty period, whichever occurs later. Warranted parts shall be provided at no cost to the user at an authorized Bush Hog dealer during regular working hours. Bush Hog reserves the right to inspect any equipment or parts which are claimed to have been defective in material or workmanship.

## DISCLAIMER OF IMPLIED WARRANTIES & CONSEQUENTIAL DAMAGES

Bush Hog's obligation under this limited warranty, to the extent allowed by law, is in lieu of all warranties, implied or expressed, **INCLUDING IMPLIED WARRANTIES OF MERCHANTABILITY AND FITNESS FOR A PARTICULAR PURPOSE** and any liability for incidental and consequential damages with respect to the sale or use of the items warranted. Such incidental and consequential damages shall include but not be limited to: transportation charges other than normal freight charges; cost of installation other than cost approved by Bush Hog; duty; taxes; charges for normal service or adjustment; loss of crops or any other loss of income; rental of substitute equipment, expenses due to loss, damage, detention or delay in the delivery of equipment or parts resulting from acts beyond the control of Bush Hog.

### THIS LIMITED WARRANTY SHALL NOT APPLY:

1. To vendor items which carry their own warranties, such as engines, tires, and tubes.
2. If the unit has been subjected to misapplication, abuse, misuse, negligence, fire or other accident.
3. If parts not made or supplied by Bush Hog have been used in connection with the unit, if, in the sole judgement of Bush Hog such use affects its performance, stability or reliability.
4. If the unit has been altered or repaired outside of an authorized Bush Hog dealership in a manner which, in the sole judgement of Bush Hog, affects its performance, stability or reliability.
5. To normal maintenance service and normal replacement items such as gearbox lubricant, hydraulic fluid, worn blades, or to normal deterioration of such things as belts and exterior finish due to use or exposure.
6. To expendable or wear items such as teeth, chains, sprockets, belts, springs and any other items that in the company's sole judgement is a wear item.

NO EMPLOYEE OR REPRESENTATIVE OF BUSH HOG IS AUTHORIZED TO CHANGE THIS LIMITED WARRANTY IN ANY WAY OR GRANT ANY OTHER WARRANTY UNLESS SUCH CHANGE IS MADE IN WRITING AND SIGNED BY BUSH HOG'S SERVICE MANAGER, 2501 GRIFFIN AVE., SELMA, ALABAMA 36703.



Record the model number, serial number and date purchased. This information will be helpful to your dealer if parts or service are required.

MODEL NUMBER \_\_\_\_\_

SERIAL NUMBER \_\_\_\_\_

DATE OF RETAIL SALE \_\_\_\_\_

MAKE CERTAIN THE WARRANTY HAS BEEN FILED WITH BUSH HOG SELMA, ALABAMA

# RTC50G ROTARY TILLER

## ALPHABETICAL INDEX

<b>CONTENTS</b>	<b>PAGE</b>
RTC50G Rotary Tiller .....	30-1-1, 30-1-2
PTO Shaft .....	30-2-1
Slip Clutch Complete .....	30-2-2
Decals - Safety and Marking.....	30-3-1

# RTC50G ROTARY TILLER

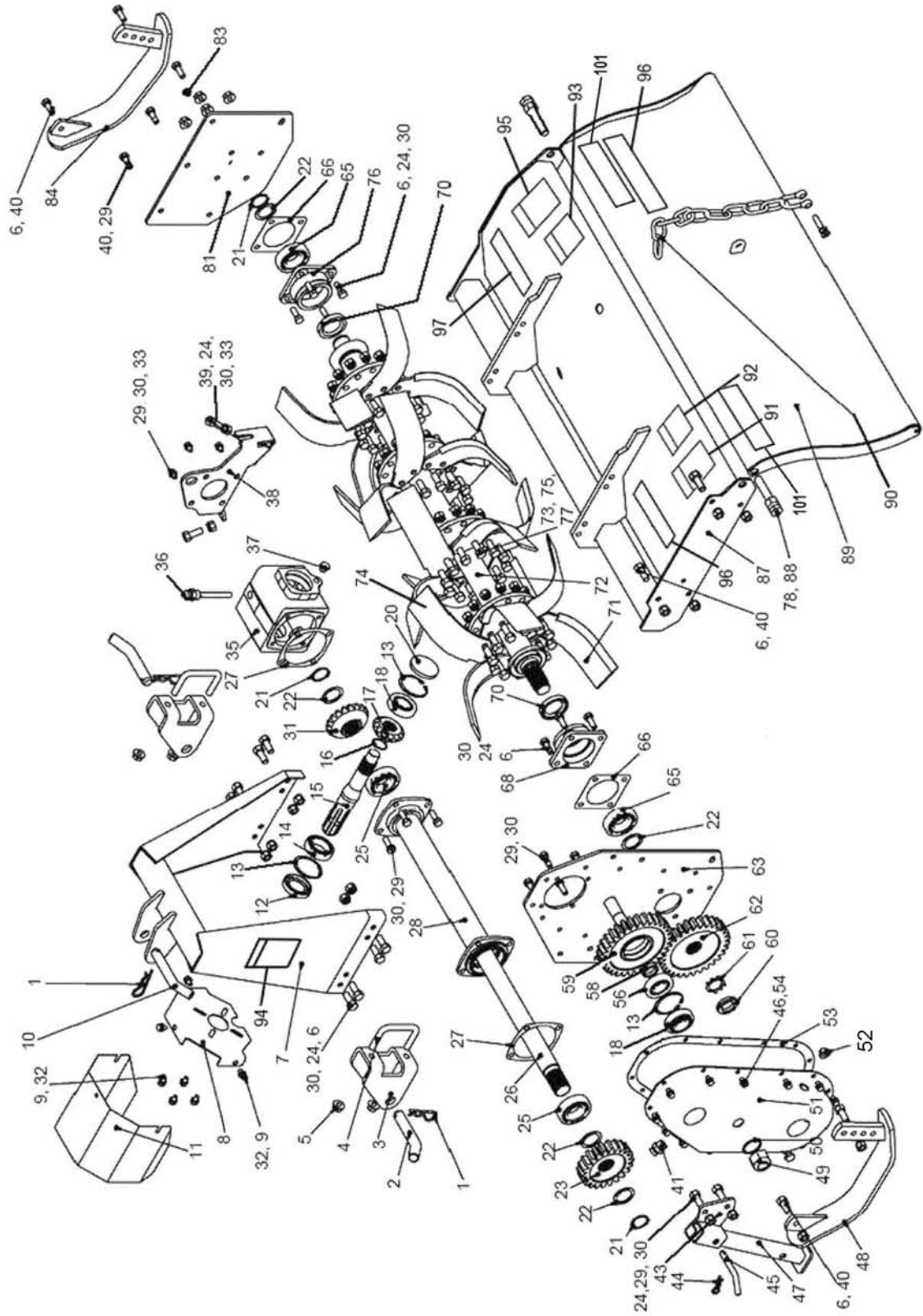

## RTC50G ROTARY TILLER

Ref. No.	Part No.	Description	Qty.	Ref. No.	Part No.	Description	Qty.
1	50073976	"R" clip - 4mm	3	48	50074006	Skid Weldment - Left (Red)	1
2	50073977	Hitch Pin (Lower Hitch Block)	2		50074006-03	Skid Weldment - Left (JD Green)	1
3	50073978	Lower Hitch Bracket (Red)	2		50074006-05	Skid Weldment - Left (Kub. Orange)	1
	50073978-03	Lower Hitch Bracket (JD Green)	2		50074006-14	Skid Weldment - Left (NH Blue)	1
	50073978-05	Lower Hitch Bracket (Kub. Orange)	2	49	50074022	Nut, 24 x 1.25	1
	50073978-14	Lower Hitch Bracket (NH Blue)	2	50	50074007	O-Ring, Idler Gear Support Shaft	1
4	50073979	"U" Bolt, Lower Hitch Bracket	2	51	50074008	Side Drive Cover (Red)	1
5	44297	Hex Nut, 12mm	4		50074008-03	Side Drive Cover (JD Green)	1
6	44202	Bolt, 10 x 1.5 x 30	24		50074008-05	Side Drive Cover (Kub. Orange)	1
7	50073980	A-Frame w/Decals (Red)	1		50074008-14	Side Drive Cover (NH Blue)	1
	50073980-03	A-Frame w/Decals (JD Green)	1	52	50077048	Oil Plug, M12 x 1.125	1
	50073980-05	A-Frame w/Decals (Kub. Orange)	1	53	50074009	Gasket - Side Gear/Chain Case	1
	50073980-14	A-Frame w/Decals (NH Blue)	1	54	44370	Bolt, 8 x 1.25 x 20	13
8	50073981	Support - Gearbox Shielding (Red)	1	58	50074010	Spacer	1
	50073981-03	Support - Gearbox Shielding (JD Green)	1	59	50074011	Idler Gear	1
	50073981-05	Support - Gearbox Shld (Kub. Org)	1	60	50074012	Spanner Nut - Rotor	1
	50073981-14	Support - Gearbox Shld (NH Blue)	1	61	50074013	Star Washer - Rotor	1
9	44316BH	Bolt, 8 x 1.25 x 16	7	62	50074014	Bottom Gear/Sprocket	1
10	50073983	Top Hitch Pin	1	63	50074015	Side Panel - Left (Red)	1
11	50073982	Gearbox Shield (Red)	1		50074015-03	Side Panel - Left (JD Green)	1
	50073982-03	Gearbox Shield (JD Green)	1		50074015-05	Side Panel - Left (Kub. Orange)	1
	50073982-05	Gearbox Shield (Kub. Orange)	1		50074015-14	Side Panel - Left (NH Blue)	1
	50073982-14	Gearbox Shield (NH Blue)	1	65	70229	Bearing 6207	2
12	50073984	Oil Seal 35-62-10	1	66	50074016	Gasket - Rotor	2
13	50073985	Snap Ring - Inner 62mm	3	68	50074017	Bearing Support	2
14	70129	Bearing 6007	1	70	50074018	Oil Seal - 40 x 62 x 10	2
15	50073986	Input Shaft	1	71	50074019	Blade - Left	15
16	50073987	Snap Ring Ext. 30mm	1	72	50074021	Rotor - RTC50G (Red)	1
17	50073988	Pinion Gear	1		50074021-03	Rotor - RTC50G (JD Green)	1
18	50047517	Bearing 30305	2		50074021-05	Rotor - RTC50G (Kub. Orange)	1
20	50073989	Gearbox Cap	1		50074021-14	Rotor - RTC50G (NH Blue)	1
21	50073990	Snap Ring Ext. 34mm	3	73	44277	Bolt, 12 x 1.25 x 35 Gr. 8.8	60
22	50073991	Shim	4	74	50074020	Blade - Right	15
23	50073992	Top Gear/Sprocket	1	75	44869BH	Hex Nut, M12 x 1.25	60
24	44342	Hex Nut, M10 x 1.5 C9 ZP	20	77	44200BH	Lockwasher, M12	60
25	50047525	Bearing 6207-2RS	2	78	44388BH	Hex Nut, M16 x 2	2
26	50073993	Drive Shaft RTC50G	1	81	50074023	Side Panel - Right (Red)	1
27	50073994	Gasket - Drive Shaft	2		50074023-03	Side Panel - Right (JD Green)	1
28	50073995	Drive Shaft Tube Housing (Red)	1		50074023-05	Side Panel - Right (Kub. Orange)	1
	50073995-03	Drive Shaft Tube Hsg (JD Green)	1		50074023-14	Side Panel - Right (NH Blue)	1
	50073995-05	Drive Shaft Tube Hsg (Kub. Org)	1	83	50074024	Grease Fitting	1
	50073995-14	Drive Shaft Tube Hsg (NH Blue)	1	84	50074025	Skid Weldment - Right (Red)	1
29	44340BH	Bolt, 10 x 1.5 x 25	17		50074025-03	Skid Weldment - Right (JD Green)	1
30	44198	Lockwasher, M10	32		50074025-05	Skid Weldment - Right (Kub. Org)	1
31	50073996	Ring Gear, Z19	1		50074025-14	Skid Weldment - Right (NH Blue)	1
32	44311BH	Lockwasher, M8	7	87	50074026	Frame Weldment w/Decals (Red)	1
33	15830	Flatwasher, 5/16	6		50074026-03	Frame Weldment w/Decals (JD Green)	1
35	50073997	Housing - Gearbox (Red)	1		50074026-05	Frame Wldmt w/Decals (Kub. Org)	1
	50073997-03	Housing - Gearbox (JD Green)	1		50074026-14	Frame Wldmt w/Decals (NH Blue)	1
	50073997-05	Housing - Gearbox (Kub. Orange)	1	88	44451BH	Bolt, 16 x 2.0 x 90	2
	50073997-14	Housing - Gearbox (NH Blue)	1	89	50074027	Tailgate RTC50G (Red)	1
36	50073998	Gearbox Oil Plug (Dip Stick)	1		50074027-03	Tailgate RTC50G (JD Green)	1
37	50073999	Oil Plug, M14 x 1.5	1		50074027-05	Tailgate RTC50G (Kub. Orange)	1
38	50074000	Lifting Hook (Red)	1		50074027-14	Tailgate RTC50G (NH Blue)	1
	50074000-03	Lifting Hook (JD Green)	1	90	50074028	Tailgate Chain Assembly	1
	50074000-05	Lifting Hook (Kub. Orange)	1	91	50074029	Decal, Warning	1
	50074000-14	Lifting Hook (NH Blue)	1	92	50074030	Decal, Warning	1
39	44390BH	Capscrew, M10 x 1.5 x 20 Gr. 8.8	2	93	50074031	Decal, Danger	1
40	50074046	Hex Nut, Flanged M10 x 1.5	11	94	50074032	Decal, Danger	1
41	50074001	Breather Cap	1	95	50074033	Decal, Danger	1
43	50074002	Stand Bracket	1	96	50057094	Decal, Bush Hog	2
44	50074003	"R" Clip - 3mm	1	97	50074034	Decal, Model	1
45	50074004	Pin - Stand	1	98	50074036	Owner's Manual, RTC50G Tiller	1
46	50074047	Hex Nut, Flanged M8 x 1.25	13	101	50031214	Red Reflector, 2 x 9	2
47	50074005	Stand Leg	1				

# PTO SHAFT

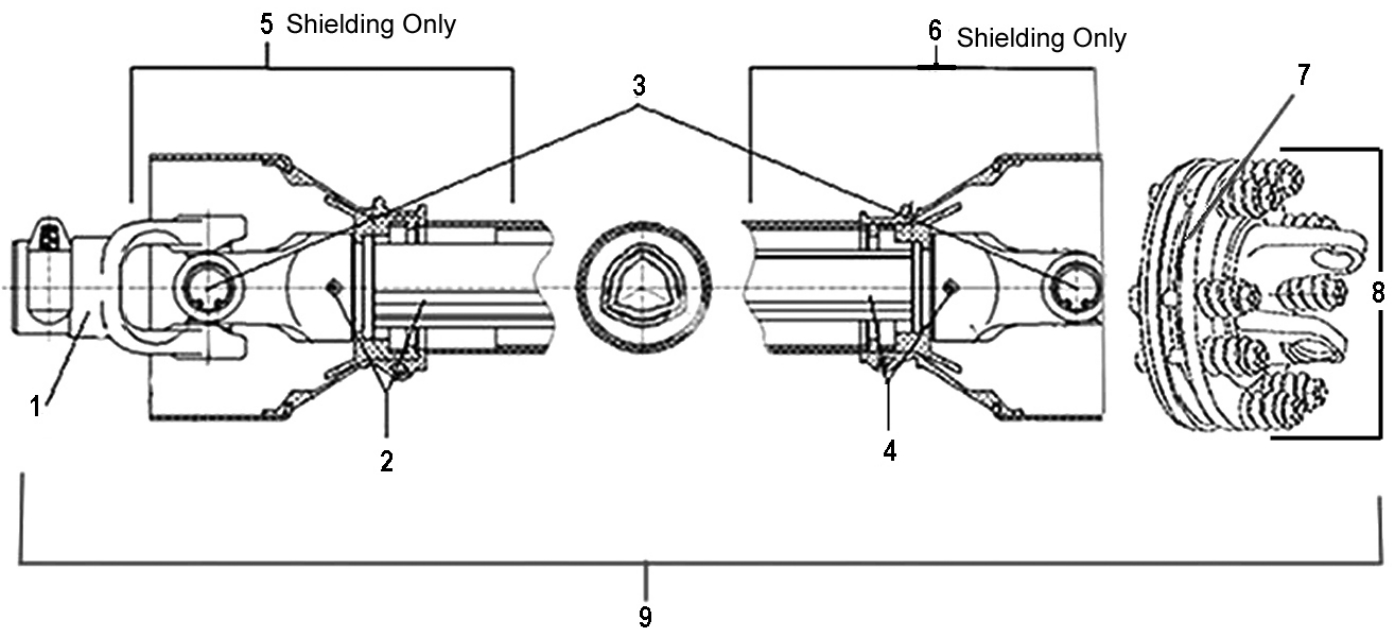

Ref. No.	Part No.	Description	Qty.
1	50074038	PTO Yoke, Series 40	1
2	50074039	Female Yoke and Tube (Tractor End), Series 40	1
3	50074040	Cross and Bearings, Series 40	2
4	50074041	Male Yoke and Tube (Implement End), Series 40	1
5	50074043	Complete Female End PTO Shielding (Tractor End), Series 20-40	1
6	50074044	Complete Male End PTO Shielding (Implement End), Series 20-40	1
7	50074042	Friction Disc - 4-3/4" OD	2
8	50074045	Slip Clutch Complete, 150mm Clutch (2 Disc)	1
9	50074037	<b>Complete PTO, Series 40, 150mm Slip Clutch</b>	<b>1</b>



### SLIP CLUTCH COMPLETE

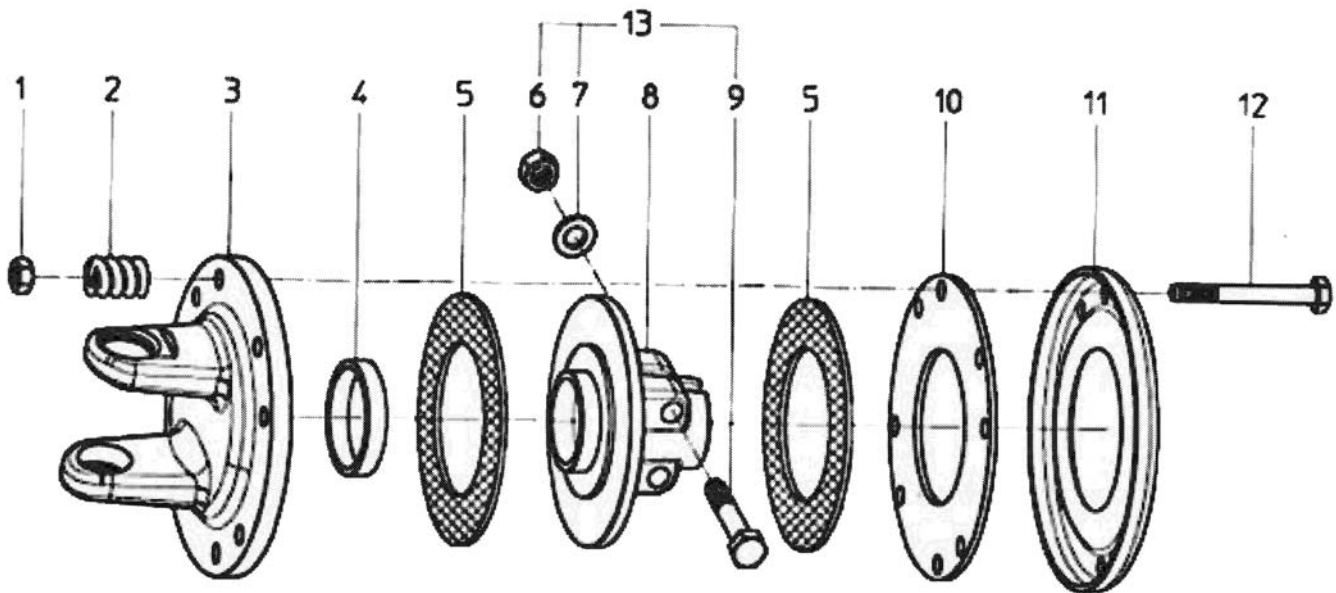

Ref. No.	Part No.	Description	Qty.
	<b>50074045</b>	<b>Slip Clutch Complete, 150mm, Clutch (2 Discs)</b>	<b>1</b>
1	—	—	-
2	50080315	Tension Spring	8
3	—	—	-
4	—	—	-
5	50074042	Friction Disc, 4-3/4" O.D.	2
6	50080317	Locknut, 12mm	2
7	50080318	Flatwasher, 12mm	2
8	—	—	-
9	50080319	Bolt, 12mm, Grade 8	2
10	50080316	Outer Pressure Plate	1
11	—	—	-
12	—	—	-
13	—	—	-



DECALS - SAFETY AND MARKING



RTC50G

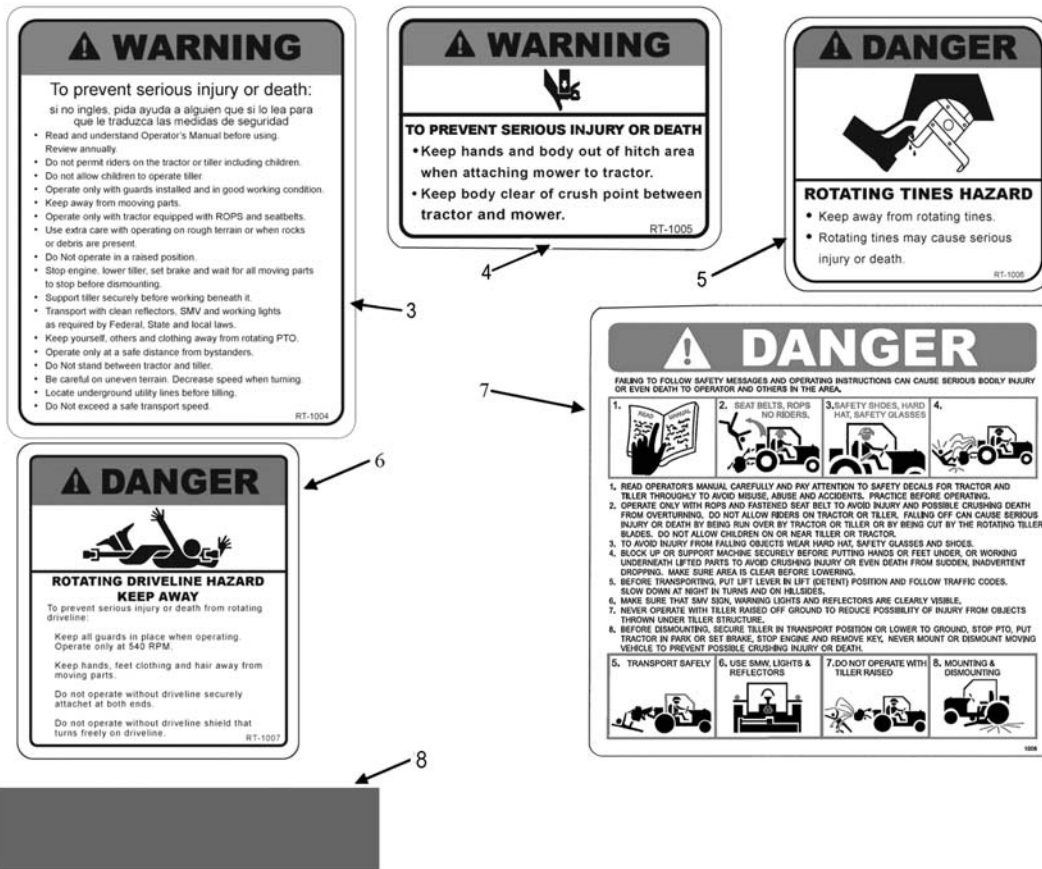

Ref. No.	Part No.	Description	Qty.
1	50057094	Decal, Bush Hog	2
2	50074034	Decal, Model	1
3	50074029	Decal, Warning	1
4	50074030	Decal, Warning	1
5	50074031	Decal, Danger	1
6	50074032	Decal, Danger	1
7	50074033	Decal, Danger	1
8	50031214	Red Reflector, 2 x 9	2







**BUSH HOG®**

2501 GRIFFIN AVE. • SELMA, AL 36703  
[WWW.BUSHHOG.COM](http://WWW.BUSHHOG.COM)