



# BUSH HOG®

# HDZ-4 SERIES ZERO TURN MOWERS

MODELS:

HDZ3155FX4, HDZ3161FX4, HDZ3173FX4,  
HDZ3355ECV4, HDZ3361ECV4, HDZ3373ECV4  
HDZ3855ECV4, HDZ3861ECV4, HDZ3873ECV4

Published 12/20

Manual Number 50081560

## OPERATOR'S MANUAL



This Operator's Manual is an integral part of the safe operation of this machine and must be maintained with the unit at all times. **READ, UNDERSTAND, and FOLLOW** the Safety and Operation Instructions contained in this manual before operating the equipment. *C01-Cover*

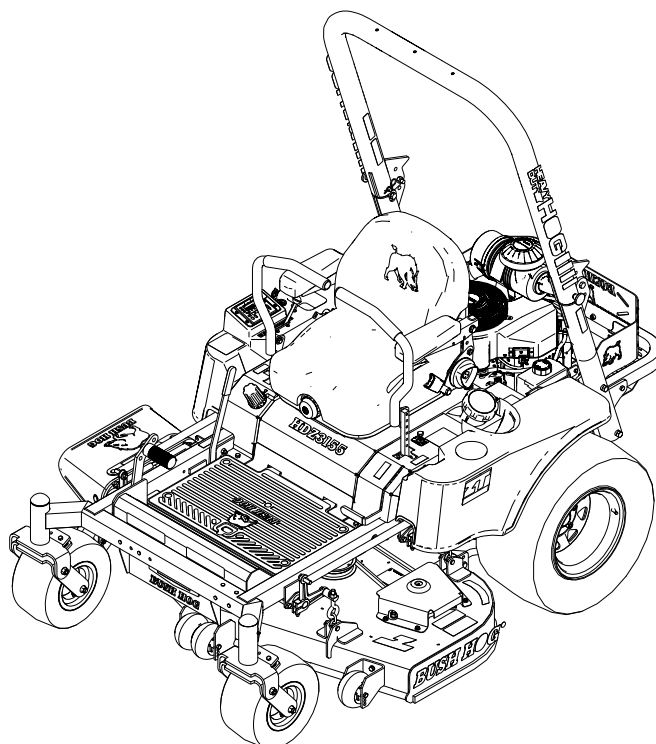

### BUSH HOG®

2501 Griffin Ave.  
Selma, AL 36703  
334-874-2700  
www.bushhog.com

Bush Hog Web Page



[www.alqr.com/bwe](http://www.alqr.com/bwe)

**¡ATENCIÓN!**  
LEA EL INSTRUCTIVO



Si No Lee Ingles, Pida  
Ayuda a Alguien  
Que Se Lo Lea Para Que lo  
Traduzca Las  
Medidas de Seguridad

**A™ MEMBER OF THE  
ALAMO GROUP**  
ALWAYS ON THE CUTTING EDGE®



**! DANGER**

Operating of this Zero Turn Mower on a Slope Exceeding 15 Degrees is unsafe and can cause upset or loss of traction resulting in death or serious injury.

## SLOPE INDICATOR

This page may be copied for personal use  
outside of this manual.

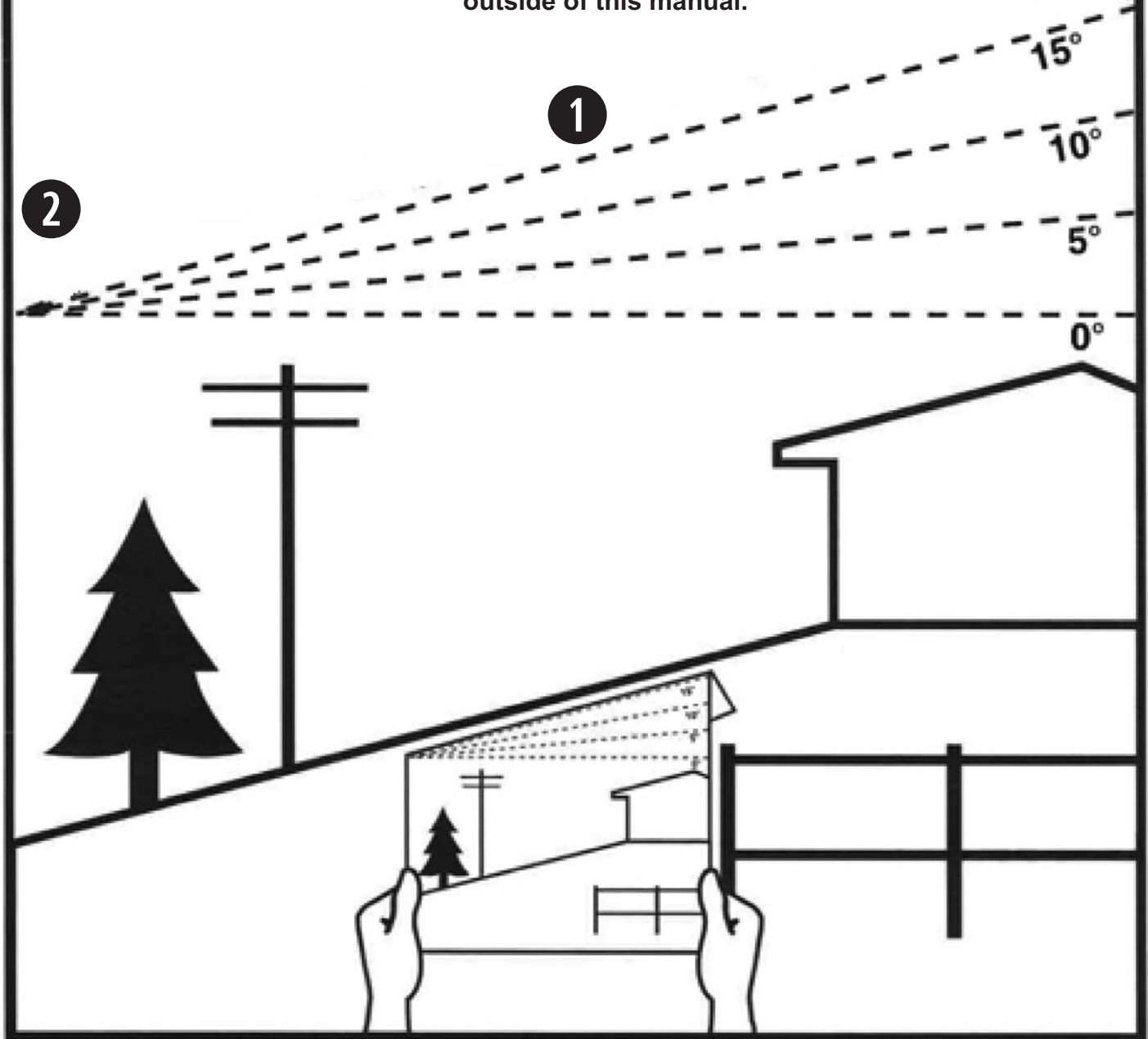

- 1 Fold along the dashed line to measure the slope being checked.
- 2 Align this edge with a vertical reference point, a tree, building, power pole, etc.
- 3 Shows example of how to compare the slope with the folded edge.



# To the Owner/Operator/Dealer

This Operator's Manual is an integral part of the safe operation of this Zero Turn Mower and must be maintained with the Zero Turn Mower at all times. A Manual holder is provided on the Zero Turn Mower where this manual can be properly stored. If you lose or damage this manual a free replacement manual can be obtained from an authorized Bush Hog dealer or by downloading the manual from the Bush Hog website [www.bushhog.com](http://www.bushhog.com)

**BEFORE YOU START! READ, UNDERSTAND, and FOLLOW** the information provided in this manual and the Engine manual carefully to learn how to operate and service your Zero Turn Mower properly. Failure to do so could result in personal injury to you and bystanders. All Zero Turn Mowers with moving parts are potentially hazardous. Every effort has been made to ensure that the Zero Turn Mower is safe but operators must avoid engaging in unsafe practices and follow the written instructions provided. The manufacturer has designed this Zero Turn Mower to be used with all its safety equipment properly attached to minimize the chance of accidents.

**SAFETY FIRST.** Completely read and understand the safety section of this manual before operating this equipment. Do not allow anyone to operate this equipment who has not fully read and understood this manual. Contact your Dealer to explain any instructions that you do not fully understand.

The care you give your Bush Hog Zero Turn Mower will greatly determine your satisfaction with its performance and its service life. Carefully read and follow the instructions in this manual to provide you with a thorough understanding of your new Zero Turn Mower and its intended use and service requirements.

All references made in this manual to right, left, front, rear, top or bottom are as viewed facing the direction of forward travel with the Zero Turn Mower.

Replacement Parts information is located in a separate Parts Manual. Bush Hog parts are made and tested to Bush Hog specifications. Non-genuine "will fit" parts do not consistently meet these specifications. The use of "will fit" parts may reduce Zero Turn Mower performance, void warranties, and present a safety hazard. Use genuine Bush Hog Zero Turn Mower parts for economy and safety. For future reference, record your Bush Hog product model number and serial number.

This unit is Approved for use on U.S. Forest Service Lands.

Dealer		Telephone		Model Number	
Owner		Purchase Date:		Serial Number	

Manual Holder located on back of seat.

Serial Number located on right hand side on the frame.

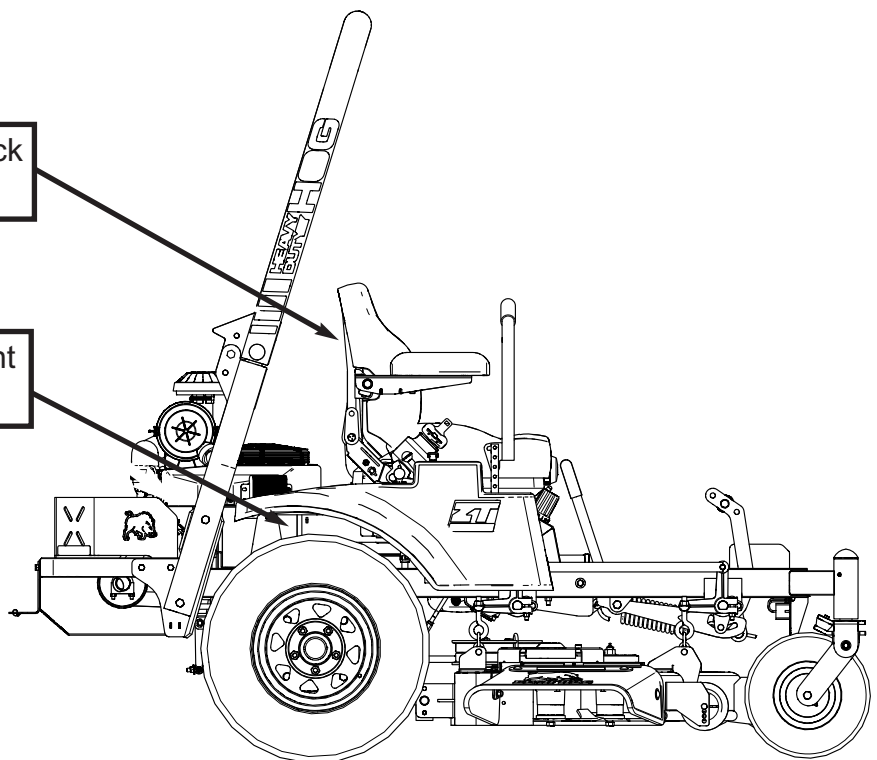

## LIMITED WARRANTY

Bush Hog warrants to the original purchaser of any new Bush Hog HDZ Series Zero Turn Mower purchased from an Authorized Bush Hog Dealer. This shall warranty that the Zero Turn Mower is free from defects in material and workmanship.

Warranty is a Three, (3) year Limited Warranty from the date of retail sale. (Third year parts only.)

Limited Lifetime Deck Weldment Warranty (Original Purchaser).

Engine Warranty is through the engine manufacturer.

The obligation of Bush Hog under these warranties are limited to repair or replacement of defective parts.

Replacement or repair parts installed in the equipment covered by this limited warranty are warranted for ninety (90) days from the date of purchase of such part or the expiration of the applicable new equipment warranty period, whichever comes later.

Warranted parts shall be provided at no cost to the user through an Authorized Bush Hog Dealer during regular hours of operation. Bush Hog reserves the right to inspect any equipment or parts which are claimed to have been defective in material or workmanship.

### DISCLAIMER OF IMPLIED WARRANTIES & CONSEQUENTIAL DAMAGES

Bush Hog's obligation under this limited warranty, to the extent allowed by law, is in lieu of all warranties, implied or expressed, **INCLUDING IMPLIED WARRANTIES OF MERCHANTABILITY AND FITNESS FOR A PARTICULAR PURPOSE** and any liability for incidental and consequential damages with respect to the sale or use of the items warranted. Such incidental and consequential damages shall include but not be limited to: transportation charges other than normal freight charges; cost of installation other than cost approved by Bush Hog; duty; taxes; charges for normal service or adjustment; loss of crops or any other loss of income; rental of substitute equipment, expenses due to loss, damage, detention or delay in the delivery of equipment or parts resulting from acts beyond the control of Bush Hog.

### THIS LIMITED WARRANTY SHALL NOT APPLY:

1. To vendor items which carry their own warranties, such as engines, tires, and tubes.
2. If the unit has been subjected to misapplication, abuse, misuse, negligence, fire or other accident.
3. If parts not made or supplied by Bush Hog have been used in connection with the unit, if, in the sole judgement of Bush Hog such use affects its performance, stability or reliability.
4. If the unit has been altered or repaired outside of an authorized Bush Hog dealership in a manner which, in the sole judgement of Bush Hog, affects its performance, stability or reliability.
5. To normal maintenance service and normal replacement items such as hydrostatic oil, worn blades, or to normal deterioration of such things as belts and exterior finish due to use or exposure.
6. To expendable or wear items such as belts, springs and any other items that in the company's sole judgement is a wear item.

***NO EMPLOYEE OR REPRESENTATIVE OF BUSH HOG IS AUTHORIZED TO CHANGE THIS LIMITED WARRANTY IN ANY WAY OR GRANT ANY OTHER WARRANTY UNLESS SUCH CHANGE IS MADE IN WRITING AND SIGNED BY BUSH HOG'S SERVICE MANAGER, 2501 GRIFFIN AVE., SELMA, ALABAMA 36703.***

Record the model number, serial number and date purchased. This information will be helpful to your dealer if parts or service are required.

MODEL NUMBER \_\_\_\_\_  
SERIAL NUMBER \_\_\_\_\_  
DATE OF RETAIL SALE \_\_\_\_\_

Make Certain that the retailing dealer has registered your warranty information with Bush Hog at time of purchase.

# DEALER PREPARATION CHECK LIST

## For NEW ZERO TURN RIDING MOWER

BEFORE DELIVERING MACHINE - The following check list should be completed. Use the Operator's Manual as a guide. Engine has been serviced.

- Ground Cable connected to Battery Negative Pole.
- Zero Turn Mower start code communicated to Owner.
- Low oil pressure light checked for operation.
- Operator interlock switches checked for operation.
- Assembly completed.
- All fittings lubricated.
- Hydraulic Reservoirs filled to Cold Fill Line with oil.
- All shields in place and in good condition.
- Roll-over Protective Structure is raised to the upright position and pinned out. This may require the upper ROPS to be rocked forward to align the Pin-Out Holes.
- Retractable seat belt functions properly.
- All fasteners torqued to specifications given in Torque Chart.
- All decals in place and readable. (See decal page.)
- Overall condition good (i.e. paint, welds)
- Parking brake checked and adjusted, if necessary.
- Steering checked and adjusted, if necessary.
- Check tire pressure.
- Warranty information has been registered on line with Bush Hog.
- Operator's manual has been delivered to owner and he has been instructed on the safe and proper use of the Zero Turn Mower.

Dealer's Signature \_\_\_\_\_

Purchaser's Signature \_\_\_\_\_

THIS CHECKLIST TO REMAIN IN OWNER'S MANUAL  
It is the responsibility of the dealer to complete the procedures listed  
above before delivery of this Zero Turn Mower to the customer.





# HDZ SERIES ZERO TURN MOWER

## TABLE OF CONTENT

### **SAFETY (SECTION 1)**

General Safety Instructions and Practices .....	1-2
Important Safety Considerations and Precautions .....	1-3
Safety Instructions and Recommendations .....	1-3
<b>OPERATOR SAFETY</b> .....	<b>1-4</b>
<b>MOWER OPERATION SAFETY</b> .....	<b>1-4</b>
Ground Speed When Mowing .....	1-4
<b>ACCIDENT PATTERNS TO AVOID</b> .....	<b>1-5</b>
Contact With The Rotating Blades.....	1-5
Mower Thrown Objects.....	1-5
Grass Discharge Chute .....	1-5
Over Turning .....	1-5
Mower Running Over Victim .....	1-5
Child Safety .....	1-5
Fuel and Grass Fires .....	1-5
<b>MOWER BLADE CONTACT HAZARDS</b> .....	<b>1-6</b>
<b>THROWN OBJECT SAFETY</b> .....	<b>1-7</b>
<b>USE ROPS &amp; SEATBELTS FOR OPERATING ON SLOPES SAFETY</b> .....	<b>1-8 / 1-9</b>
<b>RUN OVER HAZARDS</b> .....	<b>1-10</b>
<b>CHILD SAFETY</b> .....	<b>1-11</b>
<b>FUEL &amp; FIRE SAFETY</b> .....	<b>1-12 / 1-13</b>
<b>MAINTENANCE SERVICE AND STORAGE SAFETY</b> .....	<b>1-14 / 1-15</b>
<b>HIGH PRESSURE OIL LEAK HAZARD</b> .....	<b>1-16</b>
<b>BATTERY SERVICE PRECAUTIONS</b> .....	<b>1-17</b>
<b>DRIVING AND TRANSPORTING ON PUBLIC ROADS</b> .....	<b>1-18</b>
<b>PARTS INFORMATION</b> .....	<b>1-19</b>
<b>SAFETY DECAL LOCATIONS (MOWER DECK)</b> .....	<b>1-20</b>
<b>SAFETY DECAL LOCATIONS (POWER UNIT)</b> .....	<b>1-21</b>
<b>SAFETY DECAL PICTORIALS</b> .....	<b>1-22 / 1-25</b>
<b>FEDERAL LAWS and REGULATIONS</b> .....	<b>1-26</b>

### **INTRODUCTION (SECTION 2)**

INTRODUCTION .....	2-1 / 2-2
SPECIFICATIONS .....	2-3

### **CONTROLS (SECTION 3)**

CONTROL LOCATIONS.....	3-1
CONTROL PANEL.....	3-2
IGNITION SWITCH .....	3-3
PERSONALIZING YOUR KEY CODE .....	3-3
CHOKE and THROTTLE .....	3-3
STEERING CONTROL LEVERS .....	3-4
SPEED TRACKING ADJUSTMENT .....	3-4
USB CHARGING SOCKET .....	3-4
PTO SWITCH .....	3-5
CUTTING HEIGHT CONTROLS .....	3-5
FUEL TANK and FILLER NECK.....	3-5
SEAT ADJUSTMENT CONTROLS .....	3-6
TRANSAXLE BYPASS CONTROLS .....	3-6
PARKING BRAKE.....	3-7

## **OPERATION (SECTION 4)**

<b>TRAINING .....</b>	<b>4-1</b>
<b>BEFORE STARTING .....</b>	<b>4-1</b>
Starting the Engine .....	4-1
Shutting Down the Engine .....	4-1
<b>STEERING .....</b>	<b>4-2</b>
To Move Forward or Backwards .....	4-2
To Turn Left .....	4-2
To Turn Right.....	4-2
To Perform a Zero Turn .....	4-2
<b>OPERATING THE MOWER.....</b>	<b>4-2</b>
<b>ROPS and SEAT BELTS.....</b>	<b>4-3</b>
<b>REAR HITCH .....</b>	<b>4-3</b>
<b>MOWING ON SLOPES and HILLS.....</b>	<b>4-3</b>
<b>MOWING NEAR WATER, DITCHES, and EMBANKMENTS .....</b>	<b>4-4</b>
<b>MOWING TIPS.....</b>	<b>4-4</b>
<b>AFTER MOWING is COMPLETED .....</b>	<b>4-4</b>
<b>MOVING THE MACHINE MANUALLY .....</b>	<b>4-5</b>
<b>WEAK or DISCHARGED BATTERY .....</b>	<b>4-5</b>
Jumper Cable Usage .....	4-5
Starting Engine .....	4-5
Removing Jumper Cables.....	4-5

## **TRANSPORTING (SECTION 5)**

<b>TRANSPORTING THE MACHINE .....</b>	<b>5-1</b>
Preparing to Transport .....	5-1
Loading the Machine.....	5-1
Tie Down Points.....	5-1
Unloading the Machine .....	5-2

## **MAINTENANCE (SECTION 6)**

<b>RECOMMENDED REGULAR MAINTENANCE SCHEDULE .....</b>	<b>6-1</b>
<b>LUBRICATION.....</b>	<b>6-2</b>
Lubrication Points on Power Unit.....	6-2
Lubrication Points on Mower Deck .....	6-2
<b>ENGINE MAINTENANCE.....</b>	<b>6-2 / 6-3</b>
<b>SERVICING the BATTERY.....</b>	<b>6-4</b>
Keep Battery Terminal Clean - Cleaning Battery Terminals .....	6-4
Replacing the Battery.....	6-4
<b>SAFETY SYSTEM .....</b>	<b>6-5</b>
<b>PARKING BRAKE .....</b>	<b>6-5</b>
Parking Brake Adjustment.....	6-5
<b>TIRE PRESSURE .....</b>	<b>6-5</b>
<b>CASTER WHEELS .....</b>	<b>6-6</b>
<b>ANTI SCALP ROLLERS.....</b>	<b>6-6</b>
<b>MOWER DECK V-BELT .....</b>	<b>6-7</b>
Mower Deck Belt Removal.....	6-7
Mower Deck Belt Installation.....	6-7
Adjusting the Mower Deck Belt.....	6-7

<b>PUMP BELT INSTALLATION .....</b>	<b>6-9</b>
<b>CUTTING BLADE MAINTENANCE .....</b>	<b>6-9</b>
Blade Removal.....	6-9
Inspect Blades .....	6-9
Sharpening Blades.....	6-10
Installing Blades.....	6-10
<b>ADJUSTING the MOWER DECK.....</b>	<b>6-10</b>
Leveling the Deck .....	6-10
<b>TRANSAXLE MAINTENANCE.....</b>	<b>6-11</b>
Fluid and Filter Change Procedure .....	6-11
Purging Procedures .....	6-12
<b>CONSOLE MAINTENANCE .....</b>	<b>6-13- 6-15</b>
General Care .....	6-14
Bypass or Failed Safety Interlock Switch Detection.....	6-14
Service Alerts .....	6-14
Alarms.....	6-14
Console Diagnostic Codes.....	6-15
Spark Arrestor Maintenance .....	6-16

## **STORAGE (SECTION 7)**

<b>WINTER STORAGE .....</b>	<b>7-1</b>
Preparing the Machine for Storage .....	7-1
New Season Preparation .....	7-1

## **TROUBLE SHOOTING (SECTION 8)** ..... **8-1**

## **TECHNICAL DATA (SECTION 9)**

MAIN WIRING HARNESS with FUSE LOCATIONS.....	9-1
MAIN WIRING HARNESS SCHEMATIC .....	9-2
ENGINE ADAPTOR HARNESS FOR KAWASAKI ENGINES .....	9-3
ENGINE ADAPTOR HARNESS FOR KOHLER ENGINES .....	9-4
TORQUE SPECIFICATIONS .....	9-5
SERVICE and MAINTENANCE RECORDS .....	9-6
Notes Page .....	9-7



# **SAFETY SECTION 1**



# SAFETY

## GENERAL SAFETY INSTRUCTIONS AND PRACTICES

A careful operator is the best operator. Safety is of primary importance to the manufacturer and should be to the owner/operator. Most accidents can be avoided by being aware of your equipment, your surroundings, and observing certain precautions. The first section of this manual includes a list of Safety Messages that, if followed, will help protect the operator and bystanders from injury or death. Read and understand these Safety Messages before assembling, operating or servicing this Implement. This equipment should only be operated by those persons who have read the manual, who are responsible and trained, and who know how to do so responsibly.



The Safety Alert Symbol combined with a Signal Word, as seen below, is used throughout this manual and on decals which are attached to the equipment. The Safety Alert Symbol means: "ATTENTION! BECOME ALERT! YOUR SAFETY IS INVOLVED!" The Symbol and Signal Word are intended to warn the owner/operator of impending hazards and the degree of possible injury faced when operating this equipment.

Practice all usual and customary safe working precautions and above all---remember safety is up to YOU. Only YOU can prevent death or serious injury from unsafe practices.



Indicates a hazardous situation that, if not avoided, WILL result in DEATH OR VERY SERIOUS INJURY.



Indicates a hazardous situation that, if not avoided, COULD result in DEATH OR SERIOUS INJURY.



Indicates a hazardous situation that, if not avoided, MAY result in MINOR OR MODERATE INJURY.





Indicates information considered important, but not hazard-related (e.g. messages relating to property damage).

**NOTE:** Identifies points of particular interest for more efficient and convenient operation or repair.

READ, UNDERSTAND, and FOLLOW the following Safety Messages. Death or serious injury may occur unless care is taken to follow the warnings and instructions stated in this Manual and in the Safety Messages on the implement. Always follow the instruction in this manual and use good common sense to avoid hazards.



Pictographs are used throughout this manual to help bring your visual attention to safety issues.

SAFETY HAZARD	SAFETY AVOIDANCE	SAFETY PREVENTION
<p>Pictograph surrounded by a triangle indicates a Safety Hazard that must be avoided.</p> <p><i>Example:</i></p>  <p>Equipment contacting overhead electrical lines</p>	<p>Pictograph in a circle with blue or black background, by itself or inside a box, indicates an avoidance procedure or action that should be followed to prevent injuries.</p> <p><i>Example:</i></p>  <p>Wear safety footwear. Always shut off engine and remove key before working on equipment.</p>	<p>A circle with a slash through it indicates an action that is prohibited.</p> <p><i>Example:</i></p>  <p>No Smoking</p>

**NOTE:** If you want a translation of this safety section in one of the following Languages, please contact: Translations at 1502 E. Walnut Street Seguin, TX 78155; Fax: (830) 372-9529; Safety Section Translations are available in Spanish, Portuguese, French, German, Russian. PN GS-01

# SAFETY

## **IMPORTANT SAFETY CONSIDERATIONS AND PRECAUTIONS**

In addition to the design and configuration of Zero Turn Mower, hazard control and accident prevention are dependent upon the awareness, concern, prudence and proper training of personnel in the operation, transport, maintenance and storage of Zero Turn Mower. Lack of attention to safety can result in accident, personal injury, reduction of efficiency and worst of all-loss of life. Watch for safety hazards and correct deficiencies promptly. Use the following safety precautions as a general guide to safe operations when using this Zero Turn Mower. Additional safety precautions are used throughout this manual for specific operating and maintenance procedures. Read this manual and review the safety precautions often until you know the limitations.

**BUSH HOG SHARES YOUR DESIRE TO PROTECT YOURSELF, YOUR FAMILY, YOUR FRIENDS AND YOUR NEIGHBORS FROM ACCIDENTAL INJURY. OBSERVING AND ENFORCING THE FOLLOWING SAFETY INSTRUCTIONS WILL HELP TO INSURE THE SAFETY OF EVERYONE.**

## **SAFETY INSTRUCTIONS AND RECOMMENDATIONS**

PEOPLE WHO OPERATE, SERVICE, OR ARE OTHERWISE ASSOCIATED with the Zero Turning Riding Mower should be trained in its proper use and warned of its dangers. Before operating, adjusting, or servicing the Zero Turning Riding Mower they should read and understand this entire manual and the engine manual.

The following listing contains safety information specific to Bush Hog Zero Turn Mowers and other safety information that you must know and follow. This Zero Turn Mower is capable of amputating hands and feet, and of throwing objects. Always follow all safety instructions to avoid serious injury or death.

This Zero Turn Mower is designed for cutting and recycling grass, or, when equipped with a grass bagger, for catching cut grass. Any use for purposes other than these could prove dangerous to the user and bystanders.



# SAFETY

## OPERATOR SAFETY

				
Read and understand Operator's Manual	Always wear safety glasses marked with ANSI Z87	Wear Safety Shoes	Never use Drugs or Alcohol when operating equipment	Wear Hearing Protection

**⚠ WARNING TO AVOID DEATH OR SERIOUS INJURY DO THE FOLLOWING:**

- Read and understand the Zero Turn Mower and Engine Operator's Manuals before operating the Zero Turn Mower.
- Always wear safety goggles or safety glasses with side shields (marked with ANSI Z87) when operating this Zero Turn Mower.
- Always wear sturdy, rough-soled work shoes and close-fitting trousers and shirts. never operate Zero Turn Mower in bare feet, sandals, sneakers or open toe shoes.
- Always wear long pants and safety shoes with slip-resistant soles when operating this Zero Turn Mower. Do not wear shorts or any type of loose fitting clothing as they may get tangled in moving parts.
- Do not wear a towel from the waist, or use a towel as a headband or neck wrap.
- Remove jewelry and tie back long hair to prevent entangled in moving parts.
- Always wear adequate ear protection, such as ear-plugs. Prolonged exposure to loud noise can cause impairment or loss of hearing.
- Do not wear radios or music headphones while operating this Zero Turn Mower. Safe operation requires your full attention.
- Do not operate the Zero Turn Mower if you are fatigued, sick or while under the influence of alcohol or drugs, if you are pregnant or less than 18 years old.
- Poor posture or operating the Zero Turn Mower for extended periods of time may lead to fatigue or injury, resulting in loss of Zero Turn Mower control. Occasionally, stop the Zero Turn Mower and get off the seat to stretch and relax.

- Never step or stand on the Zero Turn Mower housing; stand only on the tread areas on the deck.
- Data indicates that operators, age 60 years and above, are involved in a large percentage of riding Zero Turn Mower-related injuries. These operators should evaluate their ability to operate the Zero Turn Mower safely enough to protect themselves and others from serious injury.

### MOWER OPERATION SAFETY

- Always secure the ROPS in the raised position and buckle the seat belt before starting Zero Turn Mower.
- Never leave a running Zero Turn Mower unattended.
- Before leaving the operator's seat for any reason, including unclogging the chute:
  - Always stop on level ground.
  - Disengage the Zero Turn Mower clutch.
  - Place the steering control levers in the park brake position.
  - Stop the engine
  - Wait for the engine and all moving parts to come to a complete stop







### GROUND SPEED WHEN MOWING

- NORMAL SPEED range is between 2 to 5mph.
- ADJUST MOWING SPEED for terrain conditions and grass type, density and cut height.
- REDUCE MOWING SPEED when near steep slopes, ditches, drop-offs, overhead obstructions, power lines and to avoid debris and foreign objects.
- WHEN FEASIBLE, do not operate Zero Turn Mower when grass is wet or slippery. *PN 05-ZT-03*

# SAFETY

SAFETY

## ACCIDENT PATTERNS TO AVOID

					
Hand Foot Hazard	Zero Turn Mower Thrown Object Hazard	Crushing Injury From Roll Over	Crushing Injury From Run Over	Child Run Over Hazard	Fuel and Fire Hazard

1. **CONTACT WITH THE ROTATING BLADE** - This accident usually happens when the operator is clearing the discharge chute of grass, (especially when the grass is wet), or when the operator adjusts the Zero Turn Mower without turning it off.

**WARNING** Before leaving the operator's seat for any reason, Stop the engine and wait for the blades to completely stop. See additional safety instructions in the Mower Blade Contact Safety section.

2. **ZERO TURN MOWER THROWN OBJECTS** - Sticks, rocks, wires, and other objects can be propelled out through the discharge chute or from under the Zero Turn Mower housing. Bystanders are particularly vulnerable.

**WARNING** Inspect area before mowing and remove or mark foreign solid objects, be alert and never let the Zero Turn Mower blades contact any solid objects. See additional safety instructions in the Thrown Object Safety section.

3. **GRASS DISCHARGE CHUTE** - The Zero Turn Mower shall not be operated without the grass discharge chute in its lowered position.

**WARNING** Never operate the Zero Turn Mower with the discharge shoot missing, damaged or folded up. See additional safety instructions in the Thrown Object Safety section.

4. **OVERTURNING** - This can happen when riding Zero Turn Mowers are used on slopes, embankments or hills. The operator can sustain crushing injuries during from the Zero Turn Mower rolling on top of operator.

**WARNING** The Rollover-Protection System (ROPS) is an integral and effective safety device. Keep the ROPS in the raised and locked position and use the seat belt when operating the machine. See additional safety instructions in the Operating on Slopes section.

5. **ZERO TURN MOWER RUNNING OVER THE VICTIM** - This usually happens when a Zero Turn Mower is driven in reverse. The accident victims are most often young children whom, unseen by the operator of the Zero Turn Mower, were in the area being mowed.

**WARNING** Disengage power to Zero Turn Mower before backing up. Never allow children in area when mowing. Look Behind Zero Turn Mower before backing up. See additional safety instructions in the Operating Safety section.

6. **CHILD SAFETY** - Tragic accidents can occur if the operator is not alert to the presence of children. Children are often attracted to the Zero Turn Mower and the mowing activity.

**WARNING** Do not allow children to ride on or operator Zero Turn Mower. Never allow children in area when mowing. Never assume that children will remain where you last saw them. See additional safety instructions in the Children Safety section.

7. **FUEL AND GRASS FIRES** - A fire or explosion from gasoline can burn you and others and can damage property

**WARNING** To avoid personal injury or property damage, use extreme care when handling gasoline. Gasoline is extremely flammable and the vapors are explosive. Keep Zero Turn Mower clean of grass and debris. When operating in dry areas install spark arrestor. See additional safety instructions in the Fuel and Fire Safety section. *PN OS-ZT-03*

# SAFETY

## MOWER BLADE CONTACT HAZARDS

		
<p>Do not put fingers underneath mower</p>	<p>Do not put foot underneath Zero Turn Mower deck</p>	<p>Stop Tractor Remove Key Read Manual</p>

**⚠ WARNING**

**KEEP AWAY FROM ROTATING BLADES TO AVOID DEATH OR SERIOUS INJURY FROM :**

- AVOID CONTACT WITH MOVING PARTS. Keep hands and feet from under zero turn mowing deck and away from blades at all times. Turn engine (motor) off if you must unclog the chute.
- Never leave the Zero Turn Mower unattended with engine running. Always wait for all moving parts and all sounds to stop before leaving operator's seat. Always set the parking brake on an unattended Zero Turn Mower.
- Stop on level ground, disengage drives, engage the parking brake. shut off the engine before leaving the operator's position for any reason, including emptying the catchers or unclogging the chute.
- Turn off the Zero Turn Mower blades when not mowing.
- Always keep safety shields and covers in place, except for servicing.
- Never operate the Zero Turn Mower with the floor plate pulley cover removed.
- Start the engine only from the operator's position.
- Always remain seated while operating the Zero Turn Mower.
- Always keep clear of the Zero Turn Mower blades and attachments during their operation.
- Never put hands or feet under any part of the Zero Turn Mower while it is running.

PN MB-ZT-01

# SAFETY

## THROWN OBJECT SAFETY

			
Mower Thrown Objects Hazard	Raised Zero Turn Mower Objects Thrown	Inspect Area remove foreign objects	Do not let blades contact solid objects



**ZERO TURN MOWER CAN THROW OBJECTS 100 FEET OR MORE UNDER ADVERSE CONDITIONS.**

**TO AVOID DEATH OR SERIOUS INJURY TO OPERATOR OR BYSTANDERS FROM THROWN OBJECTS:**

- KEEP bystanders 100 feet away
- **STOP MOWING IF PASSERSBY ARE WITHIN 100 FEET UNLESS:**
  - All THROWN OBJECT SHIELDING including, Discharge chute, Zero Turn Mower deck bands and Skid Rollers in place and in good condition when mowing.
  - Zero Turn Mower deck is adjusted to be close and parallel to ground without exposing blades.
  - MOWING AREA has been inspected and foreign materials and debris have been removed.
  - PASSERSBY are inside enclosed vehicle.

**KNOW AREA YOU ARE TO MOW.** Watch for hidden dangers such as rocks, roots, sticks, holes, bumps, and drop-offs, etc.

**INSPECT AREA FOR POTENTIAL THROWN OBJECTS BEFORE MOWING:**

- **REMOVE** debris, rocks, wire, cable, metal objects and other foreign material from area. Wire, cable, rope, chains and metal objects can be thrown or swing outside Zero Turn Mower deck with great velocity:
  8. **MARK** objects that cannot be removed.
  9. **AVOID** these objects when mowing.
  10. **NEVER ALLOW BLADES to CONTACT SOLID OBJECTS** like wire, rocks, post, curbs, or ground while mowing.

**HIGH GRASS and WEED AREA INSPECTION:**

- **INSPECT** area before mowing for and **REMOVE** any hidden large debris.
- **MOW** at Intermediate height
- **INSPECT** and remove remaining debris
- **MOW** at final height.

**NEVER DIRECT discharged material toward anyone.** Avoid discharging material against a wall or obstruction. Material may ricochet back toward the operator.

**DO NOT OPERATE** with Discharge chute folded up, missing, damaged or removed.

**DO NOT** mow in standing water **TO AVOID** possible **BLADE FAILURE.**

**AVOID MOWING** in reverse:

**DO NOT ENGAGE** with Zero Turn Mower deck in transport position.

**ALWAYS DISENGAGE ZERO TURN MOWER BLADES** and wait for them to stop before crossing gravel drives, walks or roads.

**Zero Turn Mower OPERATION:**

**Zero Turn Mower THROWN OBJECT SHIELDING:**

- **KEEP** all thrown object shielding including, Discharge chute, deck bands and Skid Roller in place and in good condition when mowing.
- **DO NOT** exceed Zero Turn Mower's rated Cutting Capacity or cut non-vegetative material.

**ZERO TURN MOWER SHOULD BE STOPPED AND INSPECTED FOR DAMAGE after striking a foreign object and the damage should be repaired before restarting and operating the Zero Turn Mower.**





1. **BLADES CAN FAIL** from impact and objects can be thrown with great velocity.
2. **INSPECT** and **REPLACE** any damaged blades.
3. **CHECK** blade carrier and **REPLACE** if damaged.

**Stop immediately** and check for damage or loose parts if Zero Turn Mower should start vibrating.

1. **STOP ZERO TURN MOWER** and kill **ENGINE.**
2. **INSPECT** Zero Turn Mower for vibration source.
3. **REPLACE** any damage parts and bent or damaged **BLADES.** *PN TO-ZT-01*

# SAFETY

## USE ROPS & SEATBELTS FOR OPERATING ON SLOPES SAFETY

			
Tip Over Hazard	ROPS must be in raised position	Always wear seatbelt	NO Riders

**⚠ DANGER** AVOID DEATH OR SERIOUS INJURY FROM FALLING OFF ZERO TURN MOWER, ROLLOVER AND CRUSHING BY ROLLING Zero Turn Mower

### Use the Rollover-Protection System (ROPS)

- The ROPS is an integral and effective safety device.
- Keep the ROPS in the raised and locked position
- ALWAYS BUCKLE UP seat belt when operating Zero Turn Mower.
- ONLY OPERATE Zero Turn Mower while seated in the operator's seat.
- Never attempt to start the Zero Turn Mower unless seated in the Operator's Seat with the Seat Belt securely fasten. Unintended movement could cause serious injury.
- ONLY mount or dismount when Zero Turn Mower and moving parts are stopped.
- NEVER ALLOW RIDERS on Zero Turn Mower.
- Do Not operate the Zero Turn Mower under influence of drugs or alcohol
- Lower the ROPS temporarily only when absolutely necessary. Do not wear the seat belt when the ROPS is folded down.
- Do Not lower the ROPS to mow under a tree limb. Cut the limb off or use alternative mower to mow under tree.
- Be aware there is no rollover protection when the ROPS is in the down position.
- Be certain that the seat belt can be released quickly in the event of an emergency.
- Check the area to be mowed and never fold down the ROPS in areas where there are slopes, drop offs or water.

- Keep the ROPS in safe operating condition by periodically thoroughly inspecting for damage and keeping all mounting fasteners tight.
- Replace a damaged ROPS. Do not repair or revise.
- Do Not remove the ROPS.





**Slopes are a major factor in loss-of-control and tip-over accidents, which can result in death or serious injury. All slopes require extra caution. If you cannot back the Zero Turn Mower up the slope or if you feel uneasy on the slope; do not mow it. REMINDER: Whenever possible AVOID HILLS AND SLOPES**

- DO NOT mow slopes greater than 15 degrees
- See front section of operator's manual to determine the approximate slope angle of the area to be mowed.
- DO NOT mow slopes when grass is wet slippery conditions affect steering and reduce traction and braking.
- Drive slower on slopes, Keep all movement on slopes slow and gradual.
- Do not try to stabilize the Zero Turn Mower by putting your foot on the ground. If the Zero Turn Mower's tires lose traction when operating on slopes, disengage the blades, place the steering control levers in the park brake position, stop the engine, and get help.
- Turn on the most level part of the slope.
- Be aware that loss of traction may occur going downhill. Weight transfer to the front wheels may cause drive wheels to slip and cause loss of braking and steering.

PN OS-ZT-04

# SAFETY

## USE ROPS & SEATBELTS FOR OPERATING ON SLOPES SAFETY (CONT.)





			
Tip Over Hazard	ROPS must be in raised position	Always wear seatbelt	NO Riders

- Progressively greater care is needed as the slope increases.
- Use **EXTREME** caution when mowing and/or turning across slopes as loss of traction and/or tip-over could occur. The operator is responsible for safe operation.
- If any sign of loss of traction is detected drive the Zero Turn Mower off of the slope slowly, using extreme caution. Wait until the condition that caused the problem is resolved before attempting to operate on the slope again. Terrain conditions can affect traction resulting in possible loss of control of the Zero Turn Mower. Some of the conditions to be aware of are:
  - Wet terrain
  - Depressions in the ground; i.e. holes, ruts, wash-outs
  - Mounds of dirt
  - Soil type; i.e. sand, loose dirt, gravel, clay
  - Grass type, density, and height
  - Extremely dry conditions of grass
  - Tire pressure
- Watch for ditches, holes, rocks, dips and rises, which change the operating angle. Keep away from drop-offs and steep banks. Tall grass can hide obstacles. Remove obstacles such as rocks, tree limbs, etc.
- Use caution near drop-offs, ditches, or embankments. The Zero Turn Mower could suddenly turn over if a wheel goes over the edge of a cliff or ditch, or if an edge caves in.
- Mow a safe distance (minimum of 10 feet) away from drop-offs, retaining walls, drainage ditches, embankments, water, and other types of hazards to avoid a wheel dropping over the edge or to avoid the ground from breaking away.
- Use a walk behind mower and/or a hand trimmer near drop-offs, ditches, steep banks or water. This area can be dangerous.
- Avoid mowing uphill - Zero Turn Mower may tip backwards. Always avoid sudden starting or stopping on a slope.
- If tires lose traction, disengage the Zero Turn Mower blades and maneuver slowly across the slope.
- Check carefully for overhead clearances (i.e. branches, doorways, and electrical wires) before driving under objects and do not contact them.
- Slow down and use extra care on hillsides. Be sure to travel side to side on hillsides. Turf conditions can affect the stability of the Zero Turn Mower. Use caution while operating near drop-offs.
- These are just a few examples of situations when caution must be used when operating on a slope. There are many other possibilities too numerous to mention. Just remember to always exercise extreme caution when operating on any slope.
- The ROPS may minimize chance of injury or death from rollover. The seat belt must be fastened while operating a Zero Turn Mower equipped with a ROPS in the raised and secured position. Both retaining pins and hair pins must be installed. Failure to use a seat belt with ROPS may result in serious injury in the event of a roll over. *PN 05-ZT-05*



# SAFETY

## RUN OVER HAZARDS

			
Run Over Hazard	ROPS must be in raised position	Always wear seatbelt	NO Riders

**⚠ DANGER**

**TO AVOID DEATH OR SERIOUS INJURY FROM ZERO TURN MOWER RUN OVER, AND CRUSHING BY ZERO TURN MOWER:**

- **OPERATE IN DAYLIGHT** or with lights that gives at least 100 yards clear visibility.
- **BE ABLE TO SEE** and identify passersby, steep slopes, ditches, drop-offs, overhead obstructions, power lines, debris and foreign objects
- Keep the **ROPS** in the raised and locked position
- **ALWAYS BUCKLE UP** seat belt when operating Zero Turn Mower.
- **DISENGAGE POWER TO Zero Turn Mower BEFORE BACKING UP.** Do not mow in reverse unless absolutely necessary and then only after turning around and observing the entire area behind the Zero Turn Mower. Go slowly. Most "running over victim" accidents occur in reverse.
- **BEGINNING OPERATORS SHOULD LEARN HOW TO STEER** the Zero Turning Riding Mower before attempting to mow. Start with slow engine speed and drive without the blades engaged in open area until comfortable with the Zero Turn Mower.
- **KNOW HOW TO STOP QUICKLY.** Know the location and operation of every control, especially how to brake and how to disengage the Zero Turn Mower blades.
- **NEVER ALLOW RIDERS**
- **BE SURE THE AREA IS CLEAR** of other people before mowing. Stop Zero Turn Mower if anyone enters the area.
- Always be aware of what is behind the Zero Turn Mower before backing up. Never mow in

reverse. Always look down and behind before and while backing up.

- Slow down before turning
- Never attempt high speed maneuvering, especially in crowded or congested areas.
- Always maintain a safe distance from people and pets when mowing. Always stop Zero Turn Mower if someone enters the area.
- Use care when approaching blind corners, shrubs, trees, or other objects that may obscure your vision.

**INSECT INFESTATION**

- **DO NOT** operate in areas where bees or insects may attack unless you **WEAR PROTECTIVE CLOTHING.**

**LIGHTNING STORMS**

- Never operate the Zero Turn Mower when there is a risk for lightning. Lightning can cause severe injury or death.

PN RO-ZT-02

# SAFETY

## CHILD SAFETY



Run Over  
Hazard



Back Over  
Hazard



Never Allow Child  
As A Rider



Never Allow Children To  
Operate Mower



**DANGER**

**AVOID DEATH OR SERIOUS INJURY TO CHILDREN FROM Zero Turn Mower RUN OVER, AND CRUSHING BY Zero Turn Mower.**

- Keep children pets and bystanders away from an operating Zero Turn Mower.
- Never allow riders on Zero Turn Mower
- **DO NOT ALLOW CHILDREN TO OPERATE ZERO TURN MOWER.**
- Do not operate the Zero Turn Mower when children or others are in the area.

### Children

**Tragic accidents can occur if the operator is not alert to the presence of children. Children are often attracted to the Zero Turn Mower and the mowing activity. Never assume that children will remain where you last saw them.**

- Never leave the Zero Turn Mower unattended with engine running, especially with children present.
- Children or bystanders may be injured if they attempt to move or to operate the Zero Turn Mower while it is unattended. Always disengage the Zero Turn Mower deck clutch, place the control levers in park brake position, and stop the engine when leaving the operator's seat.
- Keep children out of the mowing area and under the watchful care of a responsible adult other than the operator.
- Be alert and turn the Zero Turn Mower off if children enter the area.
- Before and while backing, look behind and down for small children.

- Never carry children, even with the blades off. They may fall off and be seriously injured or interfere with safe Zero Turn Mower operation. Children who have been given rides in the past may suddenly appear in the mowing area for another ride and be run over or backed over by the Zero Turn Mower.
- Never allow children or others in or on towed equipment.
- Use care when approaching blind corners, shrubs, trees, the end of a fence or other objects that may obscure vision.
- **ALWAYS TURN ENGINE OFF** before leaving Zero Turn Mower to prevent children and inexperienced operators from starting the engine

PN CZ-ZT-01



# SAFETY

## FUEL & FIRE SAFETY

		
Fuel Fire and Explosion Hazards	Strike and explosion Hazard Blades Contacting Utility or Gas Lines	Do not operate near fires. Keep Zero Turn Mower deck clear of debris

### **NOTICE OF REQUIREMENT OF SPARK ARRESTER MUFFLER**

This equipment may create sparks that can start fires around dry vegetation. California Public Resources Code Section 4442.6 provides that it is unlawful to use or operate an internal combustion engine on any forest-covered, brush-covered, or grass-covered land unless the engine is equipped with a spark arrester maintained in effective working order. A spark arrester is a device constructed of nonflammable materials specifically for the purpose of removing and retaining carbon and other flammable particles over 0.0232 of an inch in size from the exhaust flow of an internal combustion engine that uses hydrocarbon fuels or which is qualified and rated by the United States Forest Service. Other states or federal areas may have similar laws. The Operator Should Contact Local Fire Agencies For Laws or Regulations Relating to Fire Prevention Requirements.

**THIS ZERO TURN MOWER DOES NOT COME WITH A SPARK ARRESTER. YOU SHOULD CONTACT YOUR AUTHORIZED DEALER FOR THE PURCHASE OF A SPARK ARRESTER.**

**Inspect spark arrester daily; replace every 500 hours or as needed.**

### **WARNING**

**TO AVOID DEATH OR SERIOUS INJURY FROM ELECTRICAL CONTACT WHEN WORKING AROUND ELECTRICAL POWER LINES, GAS LINES AND UTILITY LINES:**

- INSPECT mowing area for overhead or underground electrical power lines, obstructions, gas lines, cables and Utility, Municipal, or other type structure.
- KEEP Zero Turn Mower at a 10 feet or greater distance from all power lines and utility lines and obstructions.
- DO NOT allow Zero Turn Mower to contact with any Utility, Municipal, or type of structures and obstructions.

#### **Fire Prevention**

- Clean flammable material from Zero Turn Mower. Prevent fires by keeping the engine compartment, top of the deck, exhaust area, battery, fuel line, fuel tank and operator's station clean of accumulated trash, grass clippings, and other debris.
- Do not drive into or mow over burning grass or materials
- Always clean up spilled fuel and oil.
- Prevent fires by keeping the engine and exhaust areas clear of grass clippings and other debris. Do not back Zero Turn Mower into flammable materials.
- Allow the Zero Turn Mower, especially the engine, to cool before storing inside a building.

PN FF-ZT-01

# SAFETY

## FUEL & FIRE SAFETY - CONTINUED



Fuel Fire and Explosion Hazards



Strike and explosion Hazard  
Blades Contacting Utility or  
Gas Lines



Do not operate near fires.  
Keep Zero Turn Mower deck  
clear of debris





### Fuel Handling Precautions

- To avoid personal injury or property damage, use extreme care when handling gasoline. Gasoline is extremely flammable and the vapors are explosive.
- A fire or explosion from gasoline can burn you and others and can damage property.
- Observe all usual gasoline handling precautions:
- Do not smoke while refueling. Extinguish all cigarettes, cigars, pipes and other sources of ignition.
- NEVER REFUEL A Zero Turn Mower INDOORS
- Do not remove fuel cap or fill tank with engine running or while engine is hot. Clean up any gasoline spills.
- If gasoline is spilled, do not attempt to start the engine but move the Zero Turn Mower away from the area of spillage and avoid creating any source of ignition until gasoline vapors have dissipated.
- Keep gasoline away from open flame or spark and store Zero Turn Mower away from open flame or spark or pilot light such as on a water heater or appliances.
- Refuel outdoors. Never refuel or drain the gasoline from the Zero Turn Mower indoors.
- Never attempt to start the engine when there is a strong odor of gasoline fumes present. Locate and correct the cause.
- Store gasoline in an approved container and keep it out of the reach of children. Never buy more than a 30-day supply of gasoline.
- Do not fill fuel containers inside a vehicle or on a truck or trailer bed with interior carpets or plastic truck bed liners. Always place gasoline containers on the ground away from your vehicle before filling.
- When practical, remove the Zero Turn Mower from the truck or trailer and refuel the Zero Turn Mower with its wheels on the ground. If this is not possible, then refuel Zero Turn Mower on the truck or trailer using a portable container and not a fuel dispenser nozzle. If a fuel dispenser nozzle must be used, keep the nozzle in contact with the rim of the fuel tank or container opening at all times until fueling is complete. Do not use a nozzle lock-open device.
- Never use gasoline for cleaning parts.
- Avoid prolonged breathing of vapors
- Long-term exposure to vapors can cause serious injury and illness.
- Keep gasoline away from eyes and skin.
- Keep face away from nozzle and fuel tank or fuel container opening.
- If gasoline is spilled on clothing, change clothing immediately.
- Keep the nozzle in contact with the rim of the fuel tank or container opening at all times until fueling is complete.
- Do not overfill the fuel tank. Replace the fuel cap and tighten securely.

PN FF-ZT-02

# SAFETY

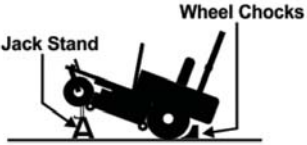
## MAINTENANCE SERVICE AND STORAGE SAFETY

			
<p>Periodically inspect all moving parts, and tighten all fasteners</p>	<p>Stop engine remove key before conducting maintenance</p>	<p>Use jack stands to support zero turn mower before servicing. Use wheel chocks to keep from rolling back. Engage parking brake.</p>	<p>Inspect Blades for damage or cracks</p>

### **WARNING**

**AVOID DEATH OR SERIOUS INJURY FROM COMPONENT FAILURE BY KEEPING ZERO TURN MOWER IN GOOD OPERATING CONDITION IN PERFORMING PROPER SERVICE, REPAIRS AND MAINTENANCE.**

**WEAR SAFETY GLASSES with side shields (marked ANSI Z87), PROTECTIVE GLOVES and follow SAFETY PROCEDURES when performing service, repairs and maintenance on the Zero Turn Mower:**

### **BEFORE PERFORMING SERVICE, REPAIRS AND MAINTENANCE ON THE Zero Turn Mower:**

#### **SECURE EQUIPMENT FOR SERVICE**

#### **BLOCK OUT POTENTIAL ENERGY HAZARDS; Rotating Parts, Raised Components, Hydraulic Pressure.**





- Disengage drives, set the parking brake, stop the engine, or disconnect spark-plug wire. Wait for all movement to stop before adjusting, cleaning, or repairing. Let engine cool and disconnect the spark plugs so the engine cannot start by accident.
- PLACE Zero Turn Mower on ground or securely block up raised Zero Turn Mower.
- Use jack stands to support components when required. Use wheel chocks to keep unit from rolling back.
- Do not run an engine in an enclosed area.
- Disconnect the battery or remove the spark-plug wire before making any repairs. Disconnect the negative terminal first and the positive terminal last. Connect the positive terminal first and negative last.

- Always WEAR protective GLOVES when handling chemicals or worn component with sharp edges.
- AVOID CONTACT with hot hydraulic oil tanks, pumps, motors, valves and hose connection surfaces.
- SECURELY support or BLOCK UP raised Zero Turn Mower, framework and lifted components before working underneath Zero Turn Mower.
- STOP any Zero Turn Mower movements and SHUT-OFF TRACTOR engine before doing any work procedures.
- DO NOT change any factory-set hydraulic calibrations to avoid component or Zero Turn Mower failures.
- DO NOT modify or alter Zero Turn Mower, functions or components.
- DO NOT WELD or repair rotating Zero Turn Mower components. These may cause vibrations and component failures being thrown from Zero Turn Mower.
- DO NOT change the engine governor setting or over speed the engine.

PN MS-ZT-01

# SAFETY

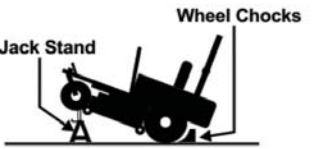
## MAINTENANCE SERVICE AND STORAGE SAFETY - CONTINUED

			
<p>Periodically inspect all moving parts, and tighten all fasteners</p>	<p>Stop engine remove key before conducting maintenance</p>	<p>Use jack stands to support zero turn mower before servicing. Use wheel chocks to keep from rolling back. Engage parking brake.</p>	<p>Inspect Blades for damage or cracks</p>

### PERFORM SERVICE, REPAIRS, LUBRICATION AND MAINTENANCE OUTLINED IN ZERO TURN MOWER MAINTENANCE SECTION:

- Clean grass and debris from the cutting unit, drives, mufflers, and engine to help prevent fires.
- Carefully release pressure from components with stored energy
- **INSPECT** for loose fasteners, worn or broken parts, leaky or loose fittings, missing or broken cotter keys and washers on pins, and all moving parts for wear.
- **REPLACE** any worn or broken parts with authorized service parts.
- **LUBRICATE** unit as specified by lubrication schedule
- **NEVER** lubricate, adjust or remove material while it is running or in motion.
- **TORQUE** all bolts and nuts as specified.

### BLADE INSPECTION:

- Use care when checking the blades. Wrap the blade(s) or wear thickly padded gloves, and use caution when servicing them. Only replace blades; do not straighten or weld them.
- **REPLACE** bent, damage, cracked or broken blades immediately with new blades.
- **AVOID** blade failures and thrown broken blades. **DO NOT** straighten, weld, or weld hard-facing blades.

### SAFETY SHIELDS, GUARDS AND SAFETY DEVICES INSPECTION:

- **KEEP** all Deflectors Chute, Integral Shields, Side Skirts and Anti Scalp Rollers in place and in good condition.
- **REPLACE** any missing, broken or worn safety shields, guards and safety devices. If any of the safety switches become inoperable, have them repaired immediately.

### **WARNING**

**Cancer and Reproductive Harm**  
[www.P65Warnings.ca.gov](http://www.P65Warnings.ca.gov)

PN MS-ZT-02

# SAFETY

## HIGH PRESSURE OIL LEAK HAZARD

		
High pressure oil penetrating skin	High pressure oil eroding skin	Using cardboard to check for oil leaks

**⚠ DANGER** TO AVOID DEATH OR SERIOUS INJURY FROM HIGH PRESSURE HYDRAULIC OIL LEAKS PENETRATING SKIN:

- **DO NOT OPERATE** equipment with oil or fuel leaks.
- **KEEP** all hydraulic hoses, lines and connections in **GOOD CONDITION** and **TIGHT** before applying system pressure.
- **RELIEVE HYDRAULIC PRESSURE** before disconnecting lines or working on the system.
- **REMOVE** and replace hose if you suspect it leaks. Have dealer test it for leaks.







**HIGH PRESSURE FLUID LEAKS CAN BE INVISIBLE.**

**WHEN CHECKING FOR HYDRAULIC LEAKS AND WORKING AROUND HYDRAULIC SYSTEMS:**

- **ALWAYS WEAR** safety glasses with side shields (marked with ANSI Z87) and impenetrable gloves.
- **USE** paper or cardboard to search for leaks.
- **DO NOT USE** hands or body parts to search for leak.
- **KEEP** hands and body **AWAY** from pin holes and nozzles ejecting hydraulic fluid.
- Injected Hydraulic fluid may cause gangrene if not surgically removed immediately by a doctor familiar with this form of injury. *PN HP01*

# SAFETY

## BATTERY SERVICE PRECAUTIONS

					
Always wear eye protection when servicing battery.	No Smoking No Open Flame near batter when charging.	Hydrogen gas inside battery may cause an explosion if exposed to a spark or flame.	Charge batteries in a ventilated area away from sparks and flames.	Metal tools can short between battery terminals and metal mower parts.	Avoid skin and clothing contact with battery acid.

### **WARNING**

Battery posts, terminals, and related accessories contain lead and lead compounds, chemicals known to the State of California to cause cancer and reproductive harm. Wash hands after handling.

- Charge batteries in a well-ventilated open area, away from sparks and flames. Unplug charger before connecting or disconnecting from battery. Wear protective clothing and use insulated tools.
- Avoid skin and clothing contact with battery acid.
- Do not drink the battery electrolyte.
- Always wear eye protection when checking the battery. Acid can cause serious injury to skin and eyes. If contact occurs, flush area with clean water and call a physician immediately. Acid will also damage clothing.
- Do not allow open flame near the battery when charging.
- Hydrogen gas forms inside the battery. This gas is both toxic and flammable and may cause an explosion if exposed to flame. Always disconnect the negative (black) battery cable(s) before disconnecting the positive (red) cable(s). Always connect the positive (red) battery cable(s) before connecting the negative (black) cable(s).
- Do not overfill the battery.
- Electrolyte may overflow and damage paint, wiring or structure. When cleaning the battery, use soap and water. Be careful not to get soap and water into the battery. Clean the battery terminals with a solution of four parts water and one part baking soda when they become corroded.
- Shorts caused by battery terminals or metal tools touching metal mower components can cause sparks. Sparks can cause a battery gas explosion which will result in personal injury.
- Prevent the battery terminals from touching any metal mower parts when removing or installing the battery.
- Do not allow metal tools to short between the battery terminals and metal mower parts.
- Incorrect battery cable routing could cause damage to the mower and battery cables. This can cause sparks which can cause a battery gas explosion which will result in personal injury.
- Always disconnect the negative (black) battery cable(s) before disconnecting the positive (red) cable(s).
- Always connect the positive (red) battery cable(s)

PN BS-ZT-03

# SAFETY

## **DRIVING AND TRANSPORTING ON PUBLIC ROADS**

Check applicable road traffic regulations before transporting on public roads. If the Zero Turn Mower is transported, you must always use approved fastening equipment and ensure that the Zero Turn Mower is well anchored. DO NOT operate this Zero Turn Mower on public roadways.

- Always observe traffic laws while driving mower from one location to another. Watch for traffic when operating near or crossing roadways.
- WATCH OUT FOR TRAFFIC near roadways and when crossing roads.
- THIS ZERO TURN MOWER IS NOT MEANT FOR HIGHWAY OR STREET USE. It is not a recreational vehicle and it should not be operated as such.

### **Hauling**

- Use care when loading or unloading the Zero Turn Mower into a trailer or a truck.
- Use full-width ramps for loading Zero Turn Mower into a trailer or a truck.
- Tie the Zero Turn Mower down securely using straps, chains, cable, or ropes. Both front and rear straps should be directed down and outward from the Zero Turn Mower.

### **Using A Ramp**

- Exercise extreme caution when loading and unloading a Zero Turn Mower onto a truck or trailer with a ramp.
- Use only a single, full width ramp; do not use individual ramps for each side of the unit. Having a full width ramp provides a surface for the Zero Turn Mower frame to contact if the unit starts to tip backwards. It also reduces the risk of a wheel going off and the Zero Turn Mower tipping over.
- Do not exceed a 15 degree angle between the ramp and the ground or between the ramp and the trailer or truck.
- Avoid sudden acceleration when on a ramp. *PN TH-ZT-02*

# SAFETY

## **PARTS INFORMATION**

### PARTS INFORMATION

Bush Hog Zero Turn Mowers use balanced and matched system components for blade components and bearings. These parts are made and tested to Bush Hog specifications. Non-genuine "will fit" parts do not consistently meet these specifications. The use of "will fit" parts may reduce Zero Turn Mower performance, void warranties, and present a safety hazard. Use genuine Bush Hog mower parts for economy and safety. (SPBH-1)

### **SEE YOUR BUSH HOG DEALER**

Operator's & Parts Manuals



[www.algqr.com/bpm](http://www.algqr.com/bpm)

SAFETY



# SAFETY

## Safety Decal Location Mower Deck

SAFETY

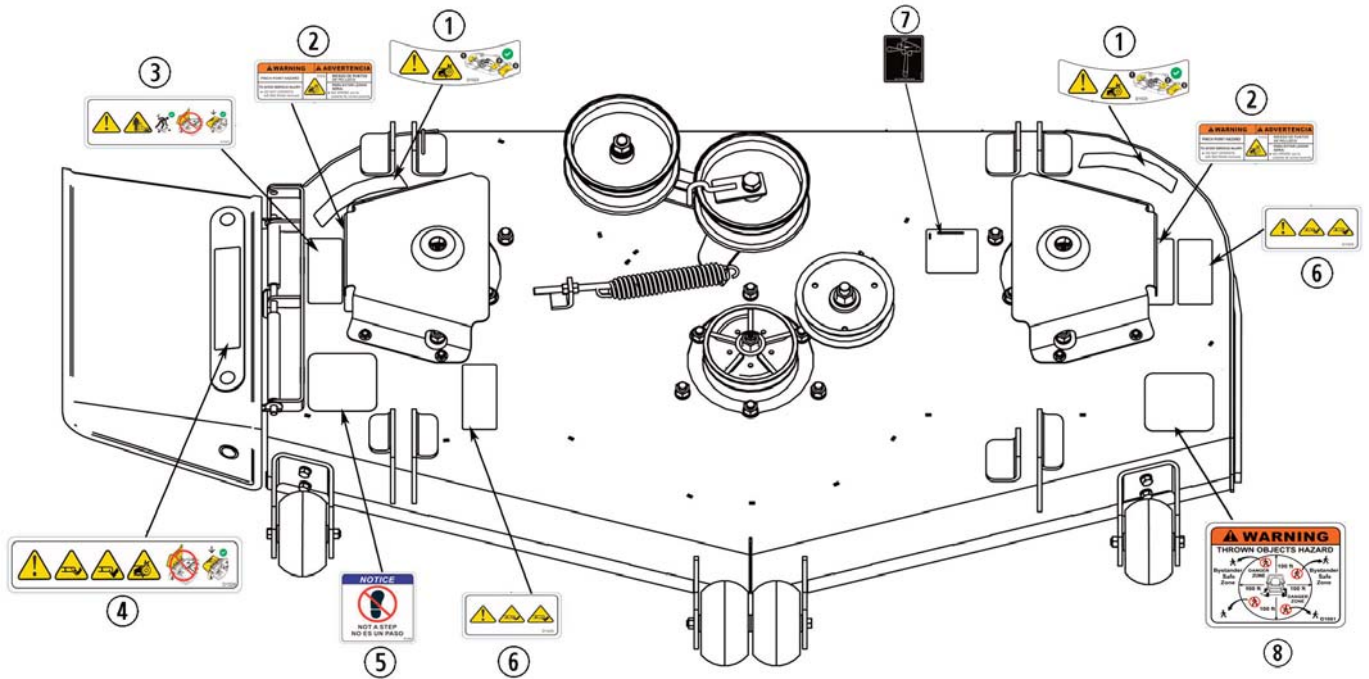

ITEM	PART NO.	QTY.	DESCRIPTION
------	----------	------	-------------

1	D1023	2	Decal, Warning - Keep Shields in Place
2	D1016	2	Decal, Warning - Pinch Points
3	D1022	1	Decal, Warning - Thrown Object Hazard
4	D1024	1	Decal, Warning - Do Not Mow Without Discharge Chute
5	D1026	1	Decal, Notice - Not A Step
6	D1025	2	Decal, Warning - Rotating Blades
7	50077946	1	Decal, Belt Installation Guide
8	D1061	1	Decal, Thrown Objects Hazard

# SAFETY

## Safety Decal Location Power Unit

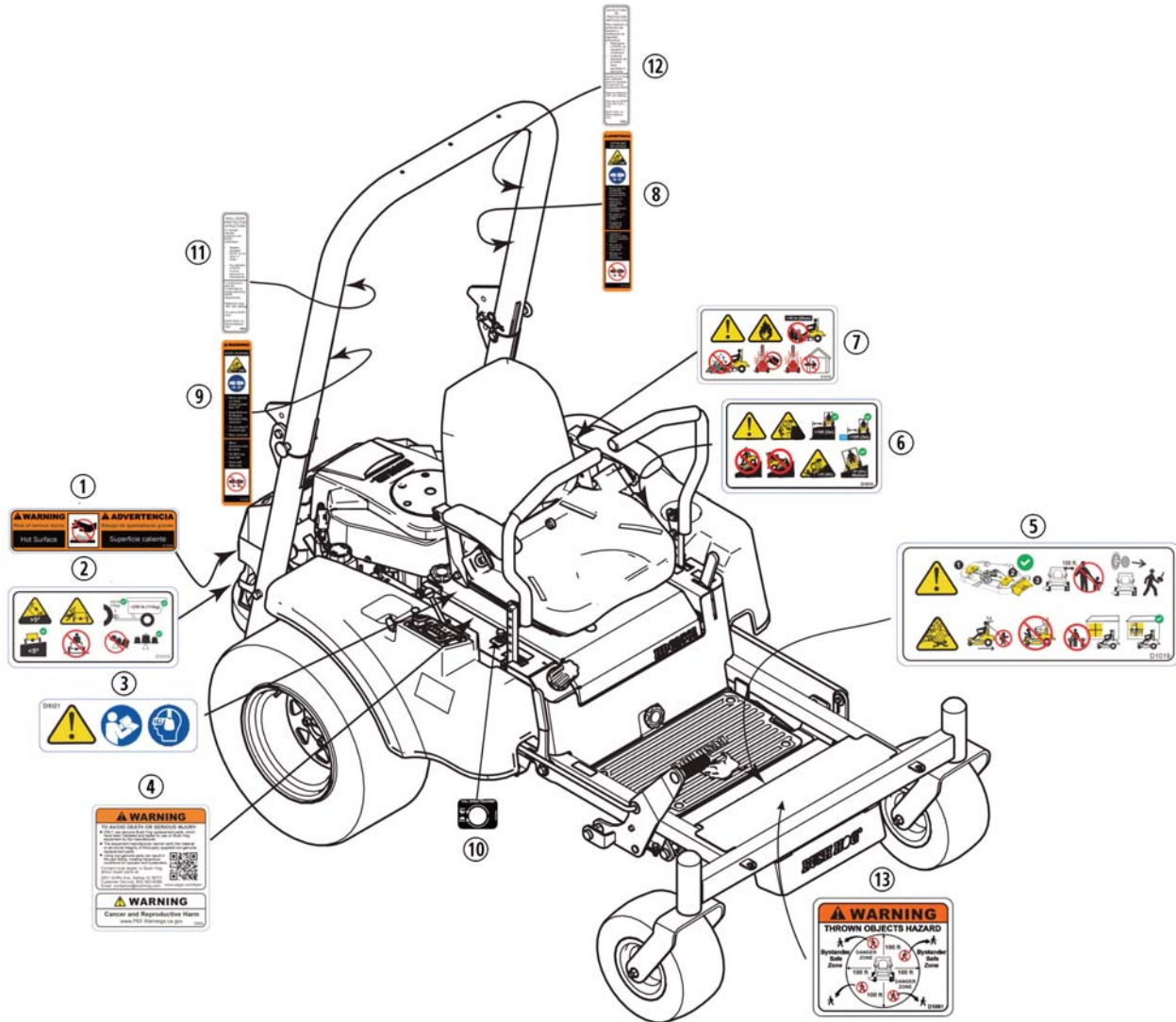

ITEM	PART NO.	QTY.	DESCRIPTION
1	D1028	1	Decal, Warning - Hot Surface
2	D1015	1	Decal, Warning - Towing
3	D1021	1	Decal, Warning - Operators Manual
4	D859	1	Decal, Warning - Genuine Bush Hog Parts
5	D1019	1	Decal, Warning - Avoid Injury
6	D1014	1	Decal, Warning - Tip Over
7	D1018	1	Decal, Warning - Equip. Fires
8	D1030	1	Decal, Warning - Hazard (Spanish)
9	D1029	1	Decal, Warning - Crushing Hazard
10	50079856	2	Decal, Tracking
11	D920	1	Decal, Instruction - Maintain ROPS (English)
12	D922	1	Decal, Instruction - Maintain ROPS (Spanish)
13	D1061	1	Decal, Warning - Thrown Object Hazards

# SAFETY

## Safety Decal Pictorials

### **WARNING**

#### **AVOID CHILD BACKOVER/ RUNOVER/BLADE INJURY**

To avoid back-over accidents, always look behind and down for small children. Never carry children, even with the blade(s) shut off. Keep bystanders, children and pets inside during operation under the watchful care of a responsible adult other than the operator. Stop tractor if anyone enters the area.



### **WARNING**

#### **AVOID TOWING RELATED INJURY**

Do not tow a load that exceeds 250lbs (113 kg) rolling weight and never exceed 50 lbs (22 kg) tongue weight. Never allow children or others in or on towed equipment. Do not tow on slopes greater than 5 degrees (9%). On slopes, the weight of the towed equipment may cause loss of traction, loss of control and/or loss of the ability to stop. Travel slowly and allow extra distance to stop.



### **WARNING**

#### **AVOID FIRES**

Your tractor is designed to cut normal residential grass of a height no more than 10" (25cm). Do not attempt to mow through unusually tall, dry grass (e.g., pasture) or piles of dry leaves. Allow a tractor to cool at least five minutes before fueling or storing inside an enclosed garage or storage shed.



### **WARNING**

#### **AVOID AMPUTATION INJURY**

Do not put hands or feet near or under the cutting deck. Contact with the blade(s) can amputate hands and feet.

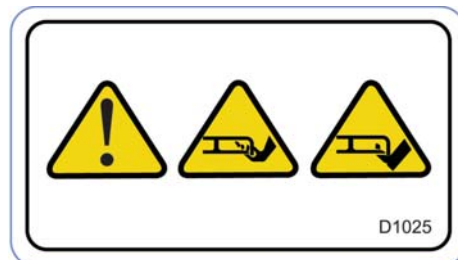

# SAFETY

## Safety Decal Pictorials

### **WARNING**

#### **AVOID THROWN OBJECTS INJURY**

Keep helpers at least 75' (23 meters) from machine during operation. Remove all stones, sticks, wire, bones, toys, and other foreign objects which could be picked up and thrown by the blade(s). Do not operate the tractor without the discharge cover or entire grass catcher in its proper place.



### **WARNING**

#### **AVOID AMPUTATION INJURY**

Do not put hands or feet near rotating parts or under the cutting deck. Contact with the blade(s) can amputate hands and feet. Ensure that all safety devices (guards, shields, switches, etc.) are in place and working. Belt and/or blade spindle contact can crush or injury body parts.



### **WARNING**

#### **AVOID TIP-OVER/ROLL-OVER INJURY**

Do not operate machine on a slope greater than 15°(25%). Do not mow up or down slopes, only mow across slopes that are less than 15 degrees (25%). Use low speeds and avoid sudden turns on slopes. Stay at least 10 feet (3 meters) from drop-offs, ditches, embankments or the edge of water.



### **WARNING**

#### **AVOID AMPUTATION INJURY**

Do not put hands or feet near rotating parts or under the cutting deck. Contact with the blade(s) can amputate hands and feet. Ensure that all safety devices (guards, shields, switches, etc.) are in place and working. Belt and/or blade spindle contact can crush or injury body parts.



# SAFETY

## Safety Decal Pictorials



### READ OPERATOR'S MANUAL - WEAR HEARING PROTECTION

Read, understand and follow all the safety rules and instructions in the manual(s) and on the tractor before attempting to operate this tractor. Failure to comply with this information may result in personal injury or death. Keep this manual in a safe location for future and regular reference. Using a Smart Phone, scan the QR code symbol to learn more information concerning the warnings contained on this tractor. You can also go to [www.OPESymbol.com](http://www.OPESymbol.com) for more information.

D1021



SAFETY

<b>⚠ WARNING</b>		<b>⚠ ADVERTENCIA</b>	
<b>PINCH POINT HAZARD</b>	<p>D1016</p>	<b>RIESGO DE PUNTOS DE PELLIZCO</b>	
<b>TO AVOID SERIOUS INJURY:</b> <ul style="list-style-type: none"> <li>• DO NOT OPERATE with Belt Shield removed.</li> </ul>		<b>PARA EVITAR LESION SERIA:</b> <ul style="list-style-type: none"> <li>• NO OPERE con la cubierta de correa ausente.</li> </ul>	

**⚠ WARNING**

**THROWN OBJECTS HAZARD**

The diagram shows a tractor in the center with a circular 'DANGER ZONE' of 100 ft radius. Four 'Bystander Safe Zones' are indicated by arrows pointing away from the tractor, each also 100 ft wide. Red 'no entry' symbols are placed at the boundaries of the danger zones.

D1061

**⚠ WARNING**

**TO AVOID DEATH OR SERIOUS INJURY:**

- ONLY use genuine Bush Hog replacement parts, which have been validated and tested to use on Bush Hog equipment by the manufacturer.
- The equipment manufacturer cannot verify the material or structural integrity of third-party supplied non-genuine replacement parts.
- Using non-genuine parts can result in the part failing, creating hazardous conditions for operator and bystanders.

Contact local dealer or Bush Hog about repair parts at:  
2501 Griffin Ave., Selma, AL 36701  
Customer Service: 800-363-6096.  
Email: [contactus@bushhog.com](mailto:contactus@bushhog.com)

[www.algqr.com/bpm](http://www.algqr.com/bpm)

**⚠ WARNING**

**Cancer and Reproductive Harm**

[www.P65Warnings.ca.gov](http://www.P65Warnings.ca.gov)

D859

# SAFETY

SAFETY

## Safety Decal Pictorials

**ADVERTENCIA**

**EVITAR SER APLASTADO**

- Nunca oper en pendientes pronunciadas mayores de 15°
- Mantener la estructura antivuelcos (ROPS) completamente extendida
- No saltar si la máquina se inclina
- Pongase el cinturón de seguridad
- Cuando la estructura debe estar en posición bajada:
- NO usar el cinturón de seguridad
- Maneje con extrema precaución

D1030

**WARNING**

**AVOID CRUSHING**

- Never operate on steep slopes greater than 15°
- Keep Rollover Protective Structure fully extended
- Do not jump if machine tips
- Wear seat belt
- When structure must be down:
- DO NOT use seat belt
- Drive with extra care

D1029

**ROLL-OVER PROTECTIVE STRUCTURE**

To maintain operator protection and ROPS certification:

- Replace damaged ROPS, do not repair or revise
- Any alteration of ROPS must be approved by manufacturer

In conformance with ISO 21299:2009 for energy absorbing ROPS requirements

Reference mass: 1967 LBS. [892Kg]

For use on BUSH HOG

BUSH HOG, Inc.  
Selma Alabama, USA

D920

**ESTRUCTURA DE PROTECCIÓN ANTIVUELCOS**

Para mantener la protección del operador y certificación de seguridad antivuelcos:

- Reemplace el ROPS, no repararlo ni modificarlo
- Cualquier alteración de la ROPS debe aprobarla el fabricante

Acorde con la norma ISO 2199:2009 sobre los requisitos de absorción de energía de la ROPS

Masa de referencia: 1967 LBS. [892Kg]

Para uso con BUSH HOG HDE, HDC y HDZ

BUSH HOG, Inc.  
Selma Alabama, USA

D922

**WARNING** Risk of serious burns

**ADVERTENCIA** Riesgo de quemaduras graves

**Hot Surface** **Superficie caliente**

D1028

**NOTICE**

**NOT A STEP**  
**NO ES UN PASO**

D1026

**FRONT**

**BELT INSTALLATION GUIDE**

5007946

# SAFETY

## **FEDERAL LAWS AND REGULATIONS**

### CONCERNING EMPLOYERS, EMPLOYEES AND OPERATIONS

This section is intended to explain in broad terms the concept and effect of federal laws and regulations. This section is not intended as a legal interpretation of the law and should not be considered as such.

U.S. Public Law 91-596 (The Williams-Steiger Occupational and Health Act of 1970) OSHA

#### **This Act Seeks:**

"...to assure so far as possible every working man and woman in the nation safe and healthful working conditions and to preserve our human resources..."

#### **DUTIES**

Sec. 5 (a) Each employer-

- (1) shall furnish to each of his employees employment and a place of employment which are free from recognized hazards that are causing or are likely to cause death or serious physical harm to his employees;
- (2) shall comply with occupational safety and health standards promulgated under this Act.
- (b) Each employee shall comply with occupational safety and health standards and all rules, regulations and orders issued pursuant to this Act which are applicable to his own actions and conduct.

### **OSHA REGULATIONS**

**Current OSHA regulations state in part: "At the time of initial assignment and at least annually thereafter, the employer shall instruct every employee in the safe operation and servicing of all equipment with which the employee is, or will be involved. "These will include (but are not limited to) instructions to:**

***Keep all guards in place when machine is in operation;***

Permit no riders on equipment;

Stop engine, disconnect the power source, and wait for all machine movement to stop before servicing, adjusting, cleaning or unclogging the equipment, except where the machine must be running to be properly serviced or maintained, in which case the employer shall instruct employees as to all steps and procedures which are necessary to safely service or maintain the equipment.

Make sure everyone is clear of machinery before starting the engine, engaging power, or operating the machine.

### **Child Labor Under 16 Years Old**

Some regulations specify that no one under the age of 16 may operate power machinery. It is your responsibility to know what these regulations are in your own area or situation. (Refer to U.S. Dept. of Labor, Employment Standard Administration, Wage & Home Division, Child Labor Bulletin #102.)





# **INTRODUCTION**

## **SECTION 2**



# INTRODUCTION

We are pleased to have you as a Bush Hog customer. Your Bush Hog Zero Turn Riding Mower has been carefully designed with care and built with quality materials by skilled workers to give maximum service with minimum down time. This manual is provided to give you the necessary operating and maintenance instructions for keeping your Zero Turn Mower in top operating condition. Careful use and timely service saves extensive repairs and costly down time losses. Please read this manual thoroughly. Understand what each control is for and how to use it. No shielding is 100% effective in preventing thrown objects. The possibility of injury and property damage from this hazard can be substantially reduced by selecting proper shielding, maintaining the Zero Turn Mower and shielding in good operational condition, inspecting the area for foreign debris before mowing, and operating the Zero Turn Mower at a minimum cutting height. Keep unprotected persons at a minimum distance of 100 feet from the Zero Turn Mower at all times during operation. Safety is of primary importance to the owner/operator and to the manufacturer. Observe all safety precaution decals on the Zero Turn Mower and noted throughout the manual for safe operation of Zero Turn Mowers. If any assistance or additional information is needed, contact your authorized Bush Hog dealer. The owner/operator/dealer should know and understand the Safety Messages before assembly and be aware of the hazards of operating this Zero Turn Mower during assembly, use, and maintenance. The Safety Alert Symbol combined with a Signal Word, as seen below, is intended to warn the owner/operator of impending hazards and the degree of possible injury faced when operating this Zero Turn Mower.



Indicates an imminently hazardous situation that, if not avoided, WILL result in DEATH OR VERY SERIOUS INJURY.



Indicates an imminently hazardous situation that, if not avoided, COULD result in DEATH OR SERIOUS INJURY.



Indicates an imminently hazardous situation that, if not avoided, MAY result in MINOR INJURY.



Identifies special instructions or procedures that, if not strictly observed, could result in damage to, or destruction of the Zero Turn Mower, attachments or the environment.

# INTRODUCTION

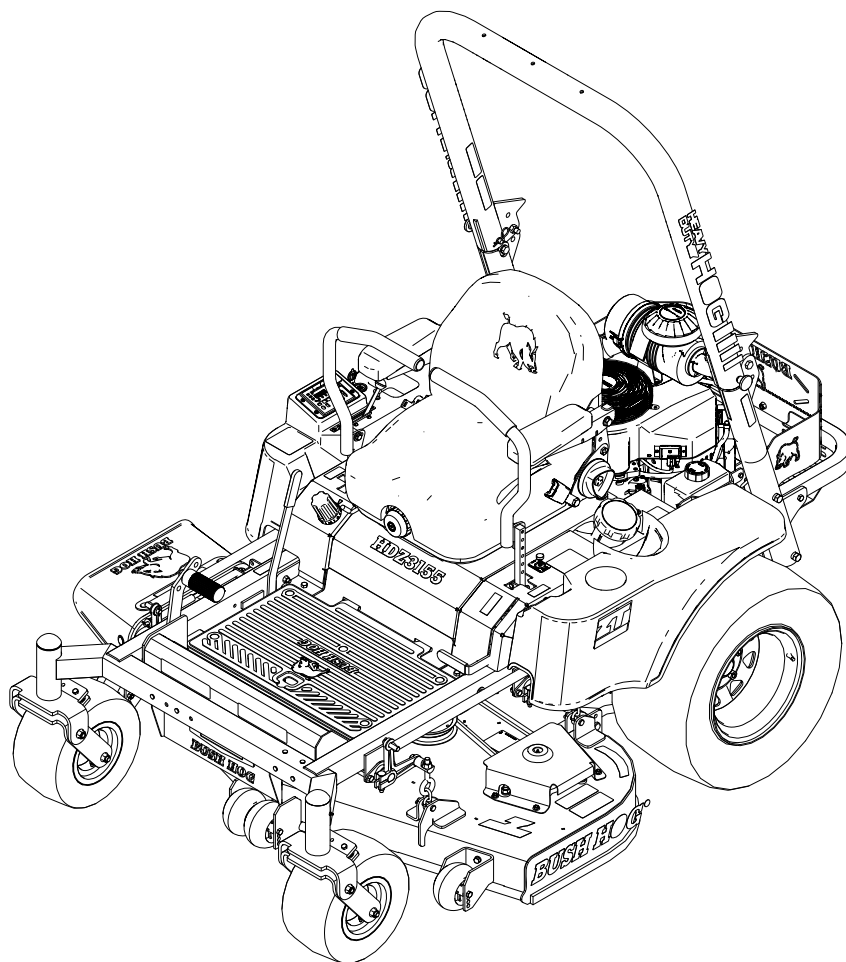

The Bush Hog Zero Turn is intended for use on lawns and other frequently maintained areas where a smooth, even cut is desired and superior maneuverability is needed. The Power Unit consists of a Kawasaki, or Kohler twin cylinder engine. The engine has a pressurized oil lubrication system with spin-on type filter, fused electronic ignition, electric start and the Zero Turn has a 8 gallon fuel system.

Literature Page



[www.algqr.com/ble](http://www.algqr.com/ble)

Two hydrostatic transaxles are used for propelling and steering. The Transaxles are belt driven by the engine output shaft. One lever for each drive controls both speed and direction. This independent control of each drive wheel coupled with continuously variable speed selection gives the Zero Turn mower exceptional maneuverability.

The Zero Turn Mower Deck is available in 55", 61" or 73" cutting widths. The Zero Turn Mower has three cutting blades, driven by an electromagnetic clutch through a single v-belt.

Front, rear, left and right are determined by the normal direction of travel, the same as driving an automobile.

# INTRODUCTION

## SPECIFICATIONS

### HDZ Series Zero Turn Mower

<b>MODEL</b>	<b>ENGINE</b>	<b>CUTTING WIDTH</b>
HDZ3155FX4 .....	31 HP Kawasaki FX921 .....	55" Deck
HDZ3161FX4 .....	31 HP Kawasaki FX921 .....	61" Deck
HDZ3173FX4 .....	31 HP Kawasaki FX921 .....	73" Deck
HDZ3355ECV4 .....	33 HP Kohler Command Pro EFI .....	55" Deck
HDZ3361ECV4 .....	33 HP Kohler Command Pro EFI .....	61" Deck
HDZ3373ECV4 .....	33 HP Kohler Command Pro EFI .....	73" Deck
HDZ3855ECV4 .....	38 HP Kohler Command Pro EFI .....	55" Deck
HDZ3861ECV4 .....	38 HP Kohler Command Pro EFI .....	61" Deck
HDZ3873ECV4 .....	38 HP Kohler Command Pro EFI .....	73" Deck
<b>CONTROLS</b> .....	Electronic Control Module with Keyless Start, System Monitoring and Soft Start PTO Engage	
<b>PTO</b> .....	Electromagnetic Clutch rated at 200 FT/LBS	
<b>FUEL CAPACITY</b> .....	8 Gallons (87 Octane Unleaded Gasoline)	
<b>TRANSAXLES</b> .....	(2) Hydro-Gear ZT5400 Hydrostats	
<b>TIRES</b> .....	Front - 13 x 6.5 - 6 (Suspension Standard) Rear - 24 x 12 - 12 (Selection of Turf tires or Bar Tires)	
<b>TREAD WIDTH</b> .....	50"	
<b>HEIGHT to TOP OF SEAT BACK</b> .....	47" Non Suspension Seat / 51" Full Suspension Seat	
<b>STEERING</b> .....	Dampened Twin Lever, Adjustable Fore, Aft and Vertical	
<b>SPEED</b> .....	Infinitely Variable 0-14 mph Forward, 0-4 mph Reverse	

### DECK SPECIFICATIONS

<b>CUTTING WIDTHS</b> .....	55" .....	61" .....	73"
<b>OVERALL WIDTH (CHUTE DOWN)</b> .....	69" .....	75" .....	89"
<b>BLADES (Standard)</b> .....	(3) 19" Uplift .....	(3) 21" Uplift .....	(3) 25" Uplift
<b>CUTTING HEIGHTS</b> .....	1-1/2" to 5" Adjustable in 1/4" Increments		
<b>DECK CONSTRUCTION</b> .....	7 Gauge reinforced steel		

### SAFETY

Integrated Operator Presence Controls  
2-7/8" Round Tube ROPS  
Seat Belts



# **CONTROLS**

## **SECTION 3**





# CONTROLS

## CONTROL LOCATIONS

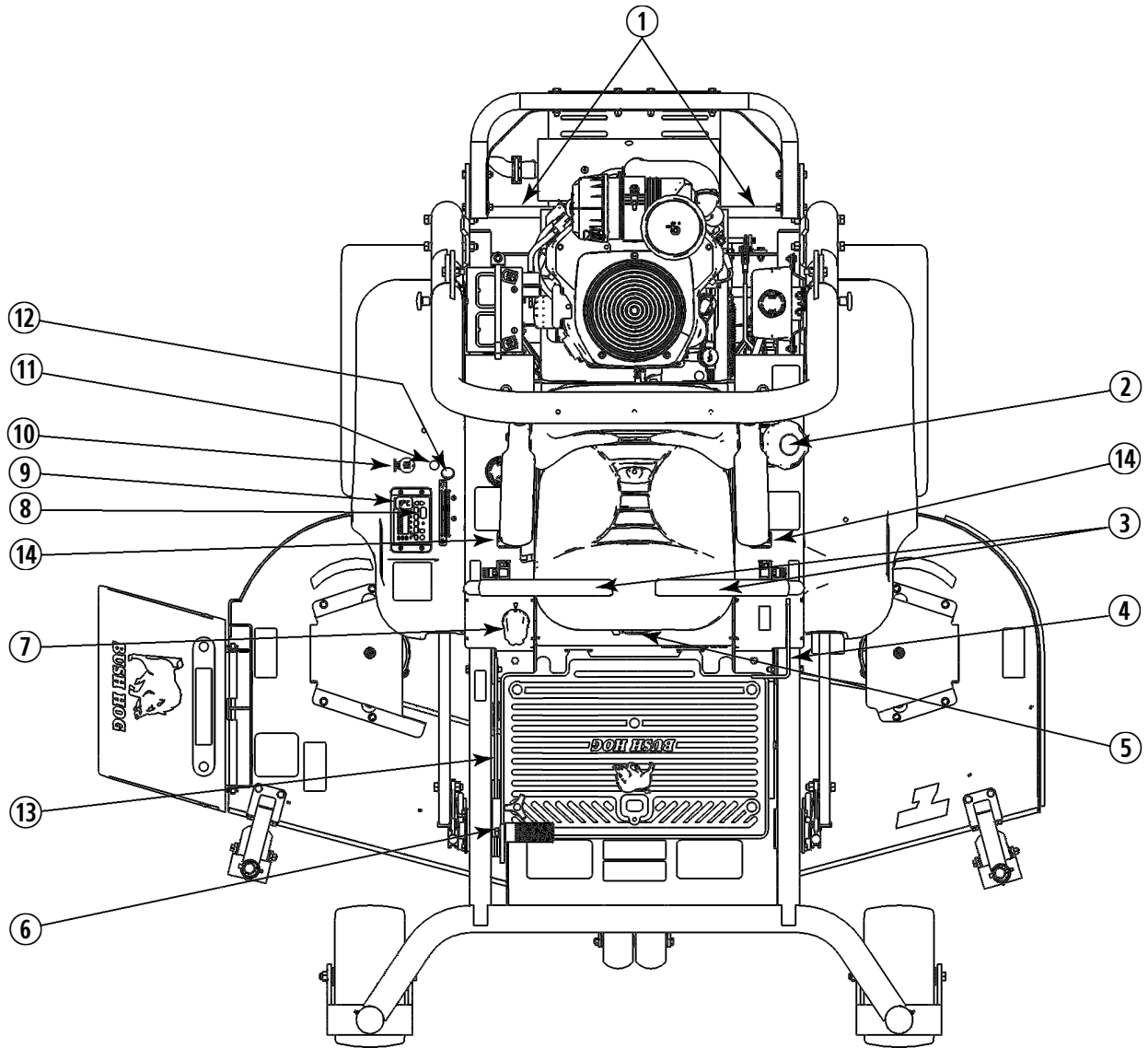

- |                               |                                |
|-------------------------------|--------------------------------|
| 1. Transaxle Bypass Linkage   | 8. Start / Stop Button         |
| 2. Fuel Cap                   | 9. Mower PTO Switch            |
| 3. Steering Control Levers    | 10. USB Charging Socket        |
| 4. Parking Brake Lever        | 11. Choke                      |
| 5. Seat Adjusting Lever       | 12. Engine Throttle Control    |
| 6. Deck Lift Pedal            | 13. Deck Transport Lock        |
| 7. Deck Height Adjusting Knob | 14. Tracking Adjusting Control |

# CONTROLS

## CONTROLS

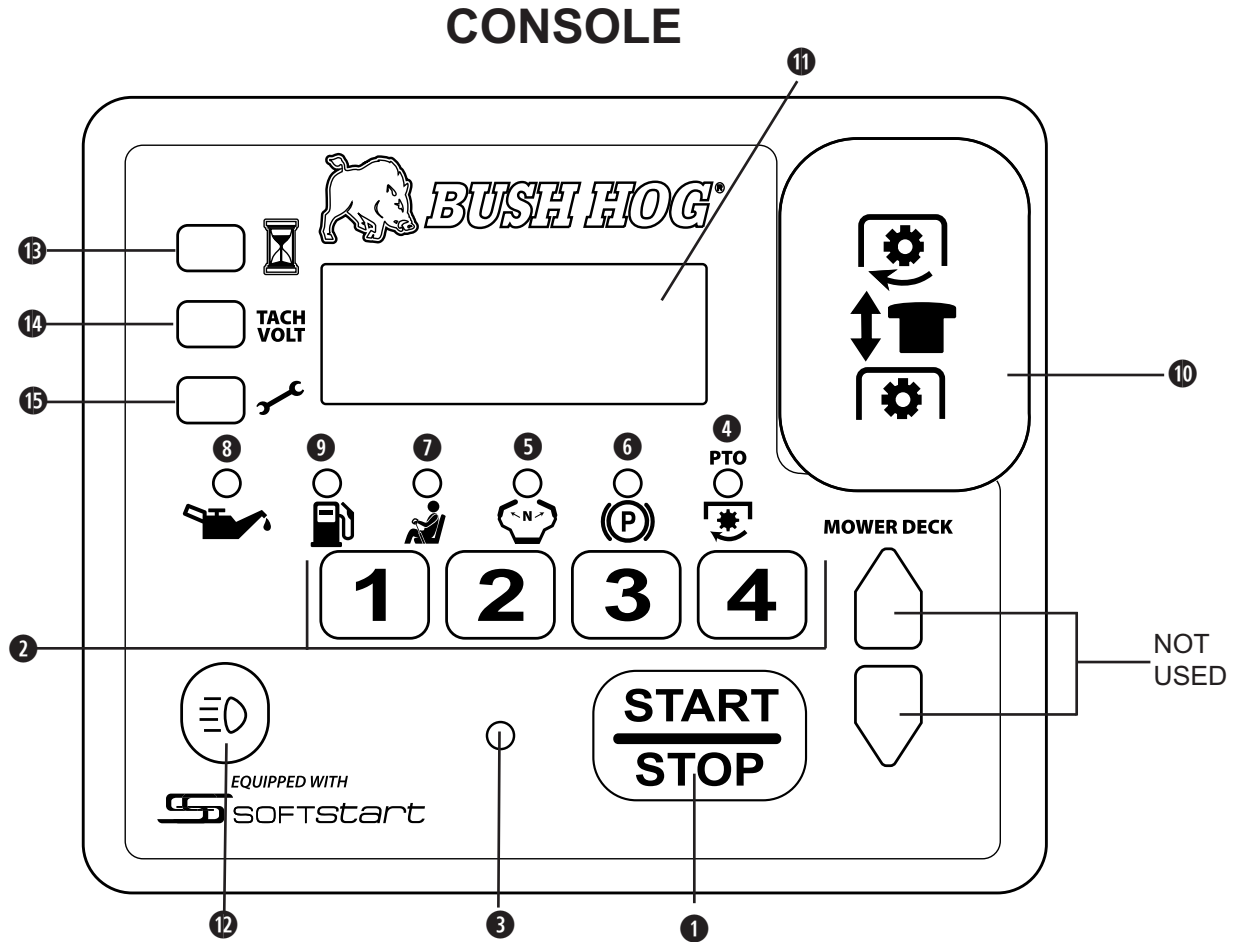

ITEM	DESCRIPTION	FUNCTION
1	Engine Start/Stop Button	Powers Engine ON / Powers Engine OFF.
2	Key Code Buttons	Powers up Console by entering Key Code and enables specific functions as starting /stopping engine, engaging PTO.
3	OK to Start Indicator Light	Glow Green when safe to start engine, Red when unsafe.
4	PTO Indicator LED	Glow Red to indicate PTO is engaged.
5	Steering Lever Indicator LED	Glow Red when Steering Levers are not in Neutral position during startup
6	Parking Brake LED	Glow Red if Parking Brake not set during startup.
7	Operator Position Indicator	Glow Red if Operator is not in seat.
8	Low Oil Indicator LED	Alerts Operator when Engine oil is low.
9	Fuel Level Indicator LED	Alerts Operator when Fuel is low.
10	PTO Switch	Engages / Disengages Mower Blades.
11	LCD Display	Indicates Hours, Service Alerts, Engine RPM, and Voltage.
12	Head Light ON/OFF Switch	Turns Head Lights On and Off.
13	Hour Meter Switch	Total Accumulated Engine Hours.
14	Tachometer / Voltage Switch	Switch between Engine RPM or System Voltage.
15	Service Engine Indicator	Indicates engine Oil Change is needed. Press down and hold for 6-9 seconds to reset after Oil Change.

# CONTROLS

## Ignition Switch

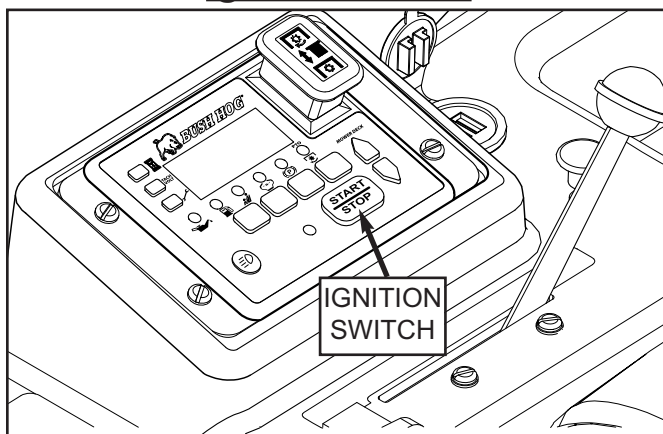

The Ignition Switch is keyless and is the Red Button on the Console located on the right hand side of the Zero Turn Mower. This controls starting and stopping the engine.

**Important** A 4 digit code must be entered before the engine can be started.

**This code will be supplied by the dealer at the time the purchaser takes ownership of the Zero Turn Mower.** A code is programmed at the factory for use until the owner changes it to his personal code.

***It is recommended that the owner personalize the code as soon as possible after taking ownership of the Zero Turn Mower.***

**See Personalizing Your Key Code.**

## PERSONALIZING YOUR KEY CODE

1. Record your new Key Code (1-12 digits) for safe keeping. **NOTE:** *Only a dealer service call can reset a forgotten code.*
2. Engine must be stopped and console unlocked (using the original code that comes with the Zero Turn Mower) and the PTO Switch down (OFF).
3. Hold KEY CODE BUTTONS 1 & 2 simultaneously for three seconds until the display shows "CHNGE" "CODE" followed by a blank screen.
4. Enter the new key code into the console. If more than 12 digits are used the display shows "FULL"  
**NOTE:** The display always shows the 5 most recently entered digits.
5. After entering the new code, pull the PTO Switch up. If the new code is unusable, the display will show "BAD" "CODE". If this occurs push the PTO switch down and return to step 1 and try a different code.  
**NOTE:** If user does not enter a code and pulls the PTO switch up the display shows "EMPTY" "CODE".

6. If the new code is usable, the console prompts the user to re-enter the code again by displaying: ENTER" "CODE" "AGAIN". Re-enter the code used in step 4, then push the PTO switch down.
7. The console confirms that the two key codes entered in step 4 and 6 match. If they do match, the console saves the new unlock code and displays "SAVED" "CODE" before returning to the previous display mode. If they do not match the console displays "NO" "MATCH" and the user must return to step 1.

**NOTE:** If no input is received for 10 seconds the console displays "TIME" "OUT" before returning to the previous display mode, retaining the previous unlock code.

**RECORD YOUR PERSONALIZED KEY CODE HERE**

## Choke and Throttle

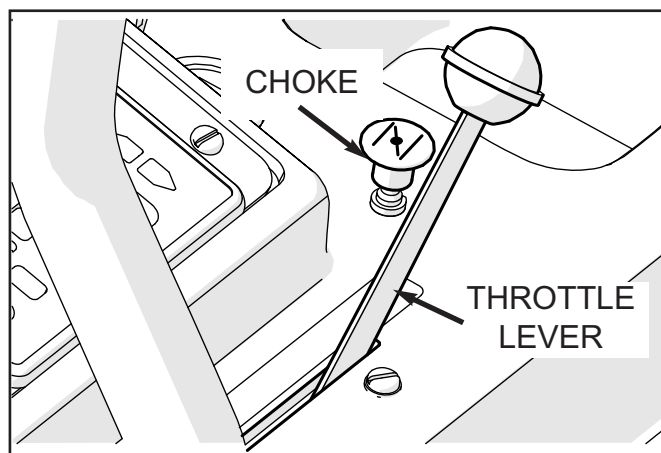

### CHOKE

The Choke provides a richer fuel mixture to the engine to assist on cold starts. Pull the choke up to engage and once the engine starts push down to disengage.

### THROTTLE

The Throttle controls the engine speed and blade speed when blades are engaged. To increase the engine and blade speeds push the Throttle forward and to decrease the speeds push the throttle toward the back. For best mowing performance run the engine at full throttle and control your ground speed with the Steering levers.

# CONTROLS

## Steering Control Levers

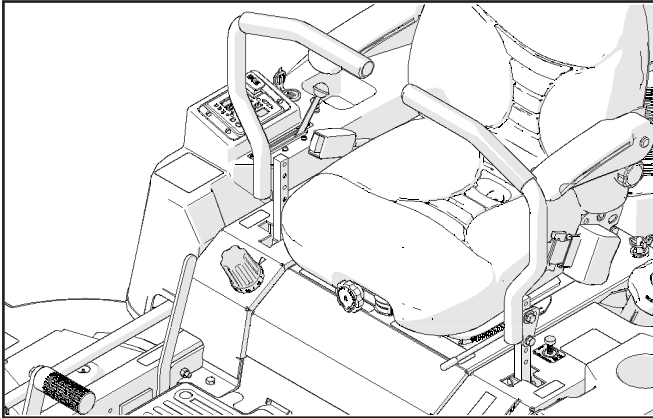

Steering Control Levers control the direction and speed of the Zero Turn Mower in both forward and reverse travel. Turning is controlled by pushing one lever forward and pulling the opposite lever backward or to the neutral position.

Moving the levers forward equally will cause the Zero Turn Mower to travel forward in a straight line. Moving the levers backward equally causes the Zero Turn Mower to travel in reverse. **The further the levers are moved forward or backward increases the speed of travel in that direction.**

**WARNING** THE ZERO TURN MOWER WILL TURN VERY RAPIDLY IF ONE STEERING LEVER IS MOVED MUCH FURTHER FORWARD THAN THE OTHER.

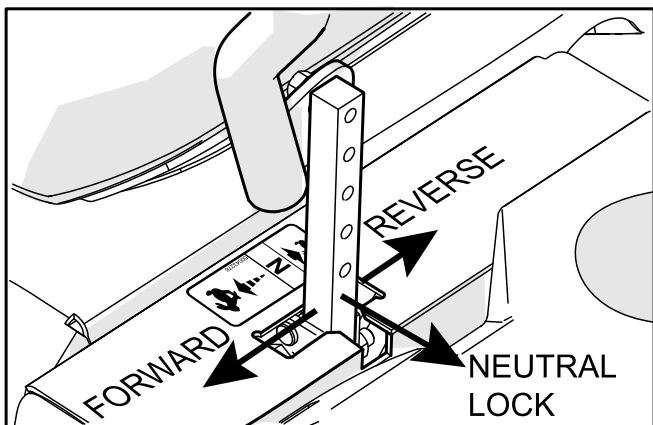

Moving the right hand lever forward and the left hand lever to the neutral position turns the Zero Turn Mower left. Moving the left hand lever forward and the right hand lever to the neutral position turns the Zero Turn Mower to the right.

Moving the right hand lever forward and the left hand lever backward the Zero Turn Mower will achieve a zero turn to the left. Moving the left hand lever forward and the right hand lever backward achieves a zero turn to the right. **These maneuvers should be done with extra care at a slow speed when turning.**

## Speed Tracking Adjusting

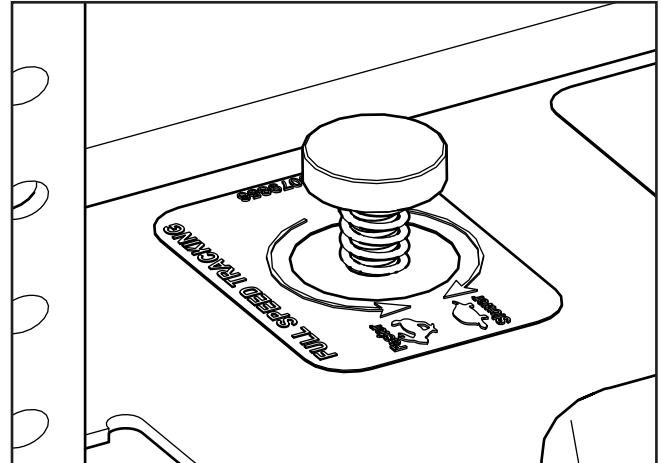

The Speed Tracking Adjustment Screws, located on the panels under the seat arm rest on each side, allow the operator to adjust the forward speed of each Steering Control Lever so the Zero Turn travels in a straight line when both Steering Levers are pushed all the way forward.

To adjust the forward speed, turn the knobs counter clockwise to increase the forward speed and clockwise to decrease the forward speed.

Test drive the mower to determine if speed tracking adjustments are required. Push the steering control levers all the way forward, if the mower steers to the right or left adjustments are needed.

- If mower steers to the right, adjust the tracking adjustment on the left side of the mower to decrease the speed of the left drive axle speed.
- If mower steers to the left, adjust the tracking adjustment on the right side of the mower to decrease the speed of the right drive axle speed.

**NOTE:** After tracking speed adjustments are completed the steering handles may need to be adjusted to the operators preferred position for comfort and best operation of the mower.

# CONTROLS

## PTO Switch

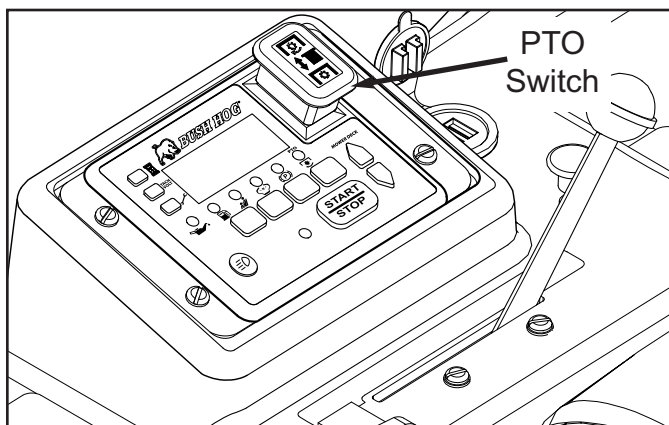

The PTO Switch is located on the Console and is Yellow in color.

To engage the Zero Turn mower blades pull the PTO Switch switch up and to disengage push the switch down.

**NOTE:** The PTO Switch should only be engaged when the engine is running and the steering levers are in the Neutral position. The Zero Turn Mower will not start if the PTO Switch is pulled up prior to starting the Zero Turn Mower. It must always be in the OFF (Down) position to start.

## Cutting Height Controls

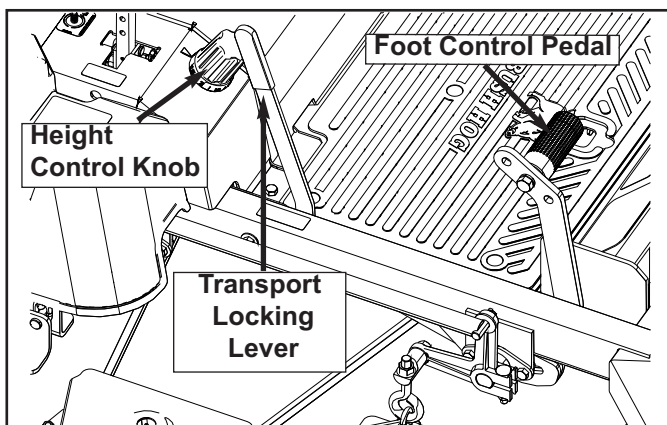

The Cutting Height is controlled by the Height Control Knob. Push the Foot Control Pedal all the way forward to lock the deck in the lockout position. Adjust the Height Control Knob to the desired cutting height by aligning the indicator point on the panel. To position the deck at the set cutting height, push the Foot Control Pedal forward while pulling back on the Transport Locking Lever and slowly let pressure off the Foot Control Pedal allowing the deck to drop to the set cutting height.

**IMPORTANT:** Always disengage the blades and raise the Zero Turn mower deck to the highest position and engage the Transport Locking Lever before transporting.

**IMPORTANT:** To maintain an even cutting height, all tires must have equal air pressure of 15 psi /103kPa / 1bar.

## Fuel Tank and Filler Neck

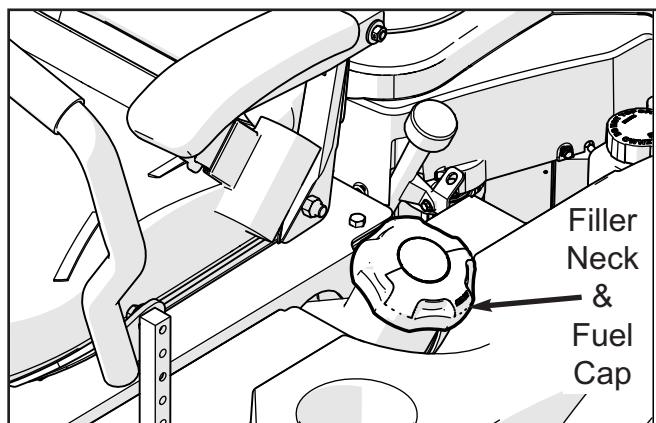

The Fuel Tank is located under the operators seat and the Filler Neck is located on the left hand side toward the rear of the seat. The Fuel Cap is tethered to the tank to avoid dropping when refueling the Zero Turn Mower.

**WARNING** Gasoline is highly flammable. The engine and exhaust system become very hot during operation.

Allow engine and exhaust system to cool down before refueling the Zero Turn Mower.

Use CAUTION and only fill outdoors.

Fill to the bottom of the filler neck (DO NOT OVER FILL).

Do not fuel the Zero Turn Mower near an open flame.

Clean away any spilled fuel after re-fueling and before re-starting the Zero Turn Mower.

Check the gas fill cap often for damage to gasket. If damaged replace the fill cap.

The engine is designed to operate on 87 Octane unleaded gasoline.

Damage to the engine may occur if E85 Alcohol based fuel or Methanol fuel is used.

# CONTROLS

## Seat Adjustment Controls

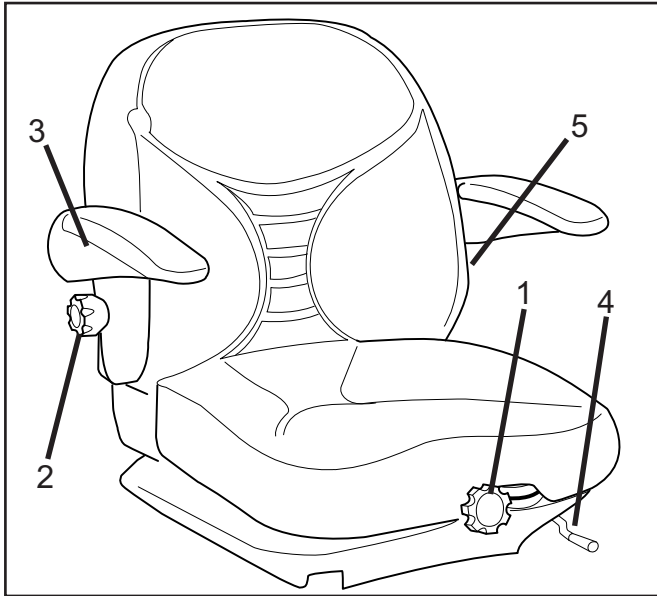

### FULL SUSPENSION SEAT

1. The Weight Adjustment Knob lets you set a personalized suspension setting.
2. The Backrest Angle Adjustment Knob.
3. Arm Rest Height adjustment (raise arm rest to access adjustment knobs).
4. Seat Slide allows 6" of fore and aft adjustment.
5. Lumbar Support Adjustment Knob.

The seat is shaped to increase air flow so that you stay more comfortable on hot days

## Transaxle Bypass Control

**NOTE:** Do not push, pull, or tow this Zero Turn Mower without first releasing the hydraulic pressure in the Integrated Transaxles.

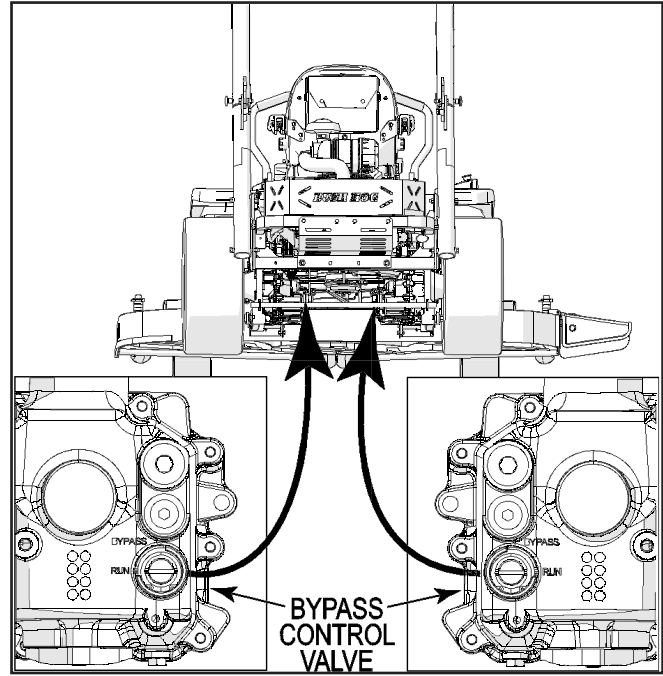

The Transaxle hydraulic fluid Bypass Control Valves are located on the front / inside of the transaxle on the underside of the Zero Turn Mower as shown above.

**CAUTION** Bypass Control Valves are close to the muffler and other HOT parts.

**NEVER attempt to manipulate the Bypass Control Valves while the engine is running.**

To prevent burn injury or physical injury turn the Zero Turn Mower off and allow for a cool down period before changing the Bypass Control Valves.

To move the zero turn mower without engine power (engine off) the Bypass Control Valve must be placed in the **BYPASS** position and parking brake off.

To relieve the hydraulic pressure on the transaxles, locate the Bypass Control Valve on the transaxle. Insert a large flat blade screw driver into the slot and turn the control 90 degrees to the **BYPASS** position. This allows the zero turn mower to be moved around without engine power.

**NOTE:** The Transaxle Bypass Control Valves must be placed back to the **RUN** Position to enable the Zero Turn Mower to move forward or backward under its engine power.

# CONTROLS

## Parking Brake

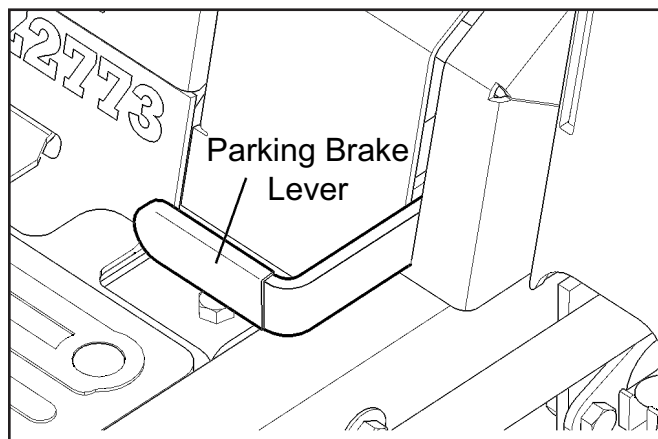

The Parking Brake is located on the left side of the Zero Turn Mower. To set the brake pull the lever up and push down to release. When engaging the brake the Zero Turn Mower must be completely motionless. *Always set the Parking Brake before dismounting the Zero Turn Mower and always release the brake before putting the Zero Turn Mower into operation.*

**NOTE:** If the Parking Brake is not set in the Park position when starting, the engine will not start and the Parking Brake LED will be lit on the console. Release the brake after the engine has started.

**NOTE:** Applying the parking brake while in forward or reverse travel and the Steering Levers in the operating position will stop the engine and could do possible damage to the Hydrostat Drives.

## USB Charging Socket

During Zero Turn Operation, the USB Charging Socket provides USB charging from 2 ports. The ports are 2.1 AMP - 5 Volt and a 1 AMP - 5 Volt.





# **OPERATION SECTION 4**



# OPERATION

## Important

If you are unfamiliar with the operation of a Zero Turn Mower, READ the Safety Section and the Controls Section before Operating.

## Training

Zero Turn Mowers are more maneuverable than conventional riding mowers because of the unique steering capabilities.

Before attempting to operate this Zero Turn Mower under its own power, the Operation Section should be reviewed entirely.

After reviewing the Operation Section, board the Zero Turn Mower (**Always from the left side or front only, never from the right hand side**). Begin slowly by practicing on a smooth, hard, level surface such as concrete or asphalt before moving to turf.

Choose an area where no people, vehicles or other obstacles are present.

Do not move the Steering Levers too aggressively to the most forward or rearward positions during your initial operation. Moving to turf before being completely comfortable with the maneuverability of this Zero Turn Mower could cause turf damage.

## Before Starting

1. Read the **Safety** and **Controls** sections before starting the *Zero Turn Mower*.
2. Do a maintenance check before starting. See Maintenance Schedule in the **Maintenance** Section.
3. Check Fuel for a sufficient amount to perform the task at hand.
4. Adjust the Operators Seat to desired position (**See Seat Adjustment Controls**).
5. Raise the Zero Turn mower deck to the transport position (highest cutting setting). (**See Cutting Height Controls**).
6. The following Control settings must be applied before the engine will start.
  - PTO Control Switch must be down (Off position).
  - Parking Brake must be set (Up position).
  - Both Steering control Levers must be in the Neutral Lock position.
  - Operator must be in the seat.

## Starting the Engine

1. Operator sitting in seat. *NOTE: The Seat is equipped with an operator presence switch and the unit will not start if operator is not sitting in the seat!*
2. Raise the Zero Turn mower deck to the transport position (highest cutting setting).
3. The PTO Switch must be disengage.
4. Engage the Parking Brake.
5. Steering Levers in the Neutral Lock position.
6. Move Throttle Control to middle position.
7. Pull Choke Up. (On cold starts)
8. Enter Console Un-Lock Code.
9. Press Start/Stop Button after the Green light is on. If the engine fails to start after 5 seconds release the Starter Button wait 10 seconds and retry.
10. When engine starts release Starter Button and push the Choke Knob down.  
**NOTE: When engine is running, engine RPM shows in the LED Display. When engine is shut down total usage Hours displayed.**
11. Allow the engine to run at a moderate speed for a short time before beginning to mow.

## Shutting Down the Engine

### Important

The Engine can be shut down at any time by simply pushing the Start/Stop Button, however this should not be done with Zero Turn mower deck engaged and forward or reverse travel in progress. This should be done only in as emergency procedures.

**NOTE: The engine will shut down during operation if the operator leaves the seat.**

### Proper Shutdown is achieved as follows:

1. Disengage the Zero Turn Mower deck by pushing the PTO Switch down.
2. Bring the engine down to idle speed.
2. Place the Steering Levers in the Neutral Lock position.
3. Set the Parking Brake.
4. Depress the Start/Stop switch.

# OPERATION

OPERATION

## Steering

Direction of travel and speed are controlled by the Steering Control Levers. The right hand lever controls the right wheel and the left hand lever controls the left wheel.

**CAUTION** All procedures listed below should be performed slowly and with caution until the operator is confident in their ability to operate this Zero Turn Mower SAFELY.

Begin with the operator sitting in the seat and adjust the seat so the operator feels comfortable with the steering controls and can easily raise and lower the deck with the Foot Control Pedal.

Begin by bringing the engine to idle speed. Release the Parking Brake. Move the Steering Levers inward from the Neutral Lock position to the Neutral position.

## To Move Forward or Backwards

Pushing the Steering Lever forward equally causes the Zero Turn Mower to travel forward in a straight line. The further forward the Levers are pushed the travel speed will increase.

Pulling the levers backward equally causes the Zero Turn Mower to travel in reverse and speed increases the further back they are pulled.

## To Turn Left

To negotiate a left hand turn while moving forward pull the left hand lever backward toward the neutral position slowing the left wheel causing the Zero Turn Mower to turn left.

## To Turn Right

To negotiate a right hand turn while moving forward pull the right hand lever backward toward the neutral position slowing the right wheel causing the Zero Turn Mower to turn right.

## To Perform a Zero Turn

Bring both Steering Levers to the neutral position until the Zero Turn Mower slows or stops.

Pushing the Left Lever slightly forward and pulling the Right Lever slightly backward negotiates a Right Hand Zero Turn.

Pushing the Right Lever slightly forward and pulling the Left Lever slightly backward negotiates a Left Hand Zero Turn.

## Operating the Mower

The Mowing Height is controlled by the Foot Control Pedal and a Height Adjusting Knob.

Mowing Height is adjustable from 1-1/2" to 5-1/2" in 1/4" increments.

NOTE: Mowing Height Adjustment should only be made with the Zero Turn Mower deck blades disengaged.

To adjust the Mowing Height, place the right foot against the knurled shaft on the Foot Control Pedal and push forward while pulling the Transport Locking Lever to the rear to release the deck. Turn the Knob to the desired cutting height to align with the indicator on the panel. Push the Foot Control Pedal all the way forward while pulling the Transport Locking Lever toward you. Slowly let pressure off the pedal allowing the mower deck to lower to the cutting height setting.

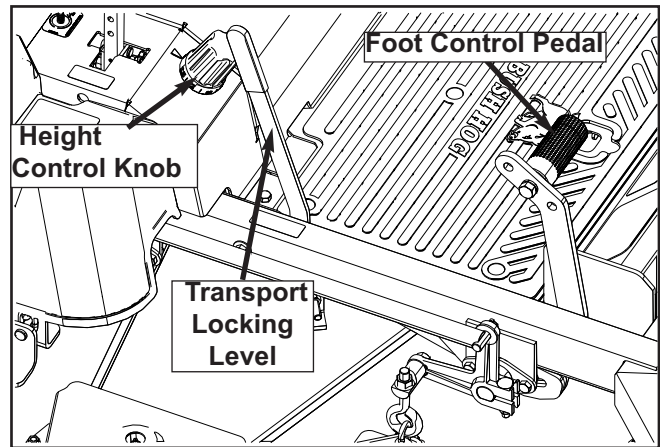

When the mowing height has been established, start the Zero Turn Mower, pull the PTO Switch up to engage the blades. Engine should be at full throttle when engaging the blades.

**WARNING** When engaging the blades make sure no one is near to the Zero Turn Mower.

Be sure the area to be mowed has been cleared of all debris that could be thrown by the rotating blades causing injury to bystanders and damage to the Zero Turn Mower.

**Best mowing results are achieved when the engine is at full throttle and ground speed is controlled by the Steering Levers.**

When mowing is completed, disengage the Zero Turn Mower deck blades by pushing the PTO Switch down.

Raise the Zero Turn Mower by pushing the Foot Control Pedal and place the Height Adjusting Pin in the 5" hole for transporting to the next location.

# OPERATION

## ROPS and Seat Belts

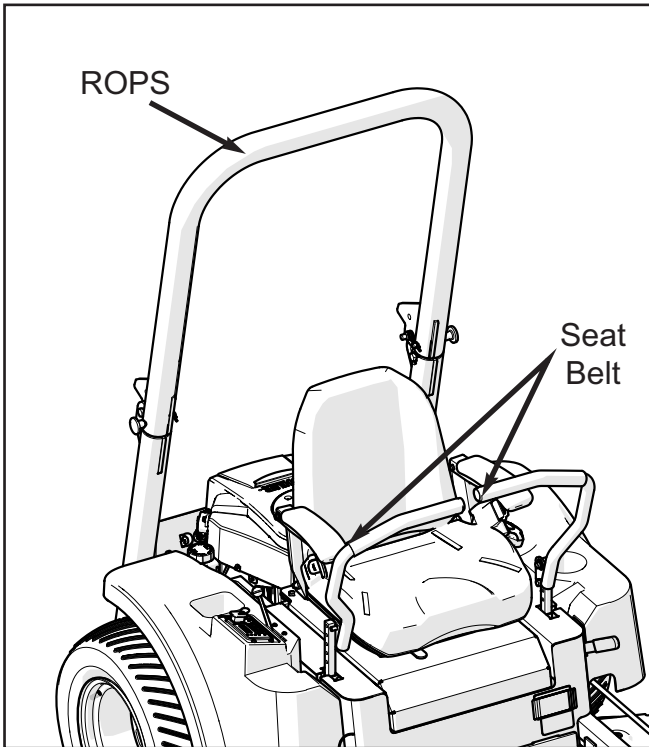

This Zero Turn Mower is equipped with a ROPS (Roll Over Protective System) and Seat Belts for the Operator's safety.

The ROPS should always be raised and locked and Seat Belt used when the Zero Turn Mower is in use. Ensure the seat is secured to the Zero Turn Mower.

**⚠ DANGER** If the ROPS must be lowered for clearance, do not wear the seat belt. There is no protection from a rollover when the ROPS is lowered. Raise the ROPS and lock in the up position as soon as clearance allows.

## REAR HITCH

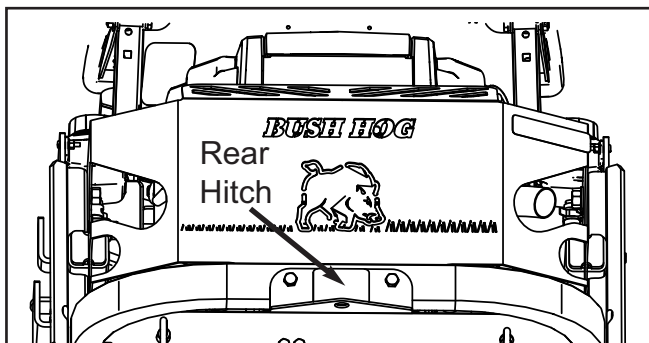

This Zero Turn Mower comes equipped from the factory with a Rear Tow Hitch. The hitch should be used to pull small yard implements such as dethatchers, seeders, fertilizer spreaders and yard carts.

**⚠ CAUTION** Implements should be towed at slow speeds on level ground and never towed on steep slopes. Tongue weight shall not exceed 25 Lbs. and implement weight shall not exceed 250 Lbs. Operator shall be cautious when towing implements due to reduced braking and overall mower handling capabilities.

## Mowing on Slope and Hills

**⚠ DANGER** Operating this Zero Turn Mower on a Slope Exceeding 15 Degrees is unsafe and can cause upset or loss of traction resulting in death or serious injury.

Refer to the Slope Indicator page in the front of this manual to determine if a Slope or Hill is too DANGEROUS to operate this Zero Turn Mower on!

Refer to SAFETY SECTION: Using ROPS & Seat Belts For Operating on Slopes Safety.

**⚠ CAUTION** To avoid tipover, drive across slopes, not up and down. If machine stops going uphill, stop blades and back down slowly..

**Mowing on wet grass can cause sliding and result in loss of control!**

1. Reduce speed to slowest speed possible before starting up or down hills.
2. Avoid stopping or changing speed on hills.
3. If you must stop, place the steering levers in the neutral lock position and engage parking brake.
4. To Restart movement release the parking brake. Move the Steering Levers out of Neutral Lock position and push forward equally to regain forward motion.
5. Make turns slowly if operator must turn on a slope or hill.

# OPERATION

## Mowing Near Water, Ditches, and Embankments

**⚠ DANGER** Operating this Zero Turn Mower near water where drop offs are present is unsafe. Wheels dropping over the edge can cause rollover or loss of traction resulting in death or serious injury by drowning.

Refer to **SAFETY SECTION: Using ROPS & Seat Belts For Operating on Slopes Safety.**

### **⚠ CAUTION**

- Watch for ditches, holes, rocks, dips and rises that can change the operating angle. Keep away from drop offs and steep banks. Tall grass can hide these obstacles.
- Use caution near drop offs, ditches, or embankments. The Zero Turn Mower can suddenly turn over if a wheel goes over an edge of a ditch, drop off, embankment, or an edge caves in.
- Mow a safe distance from water's edge (Ponds or Lakes). A Danger Zone of 10 feet should be observed.

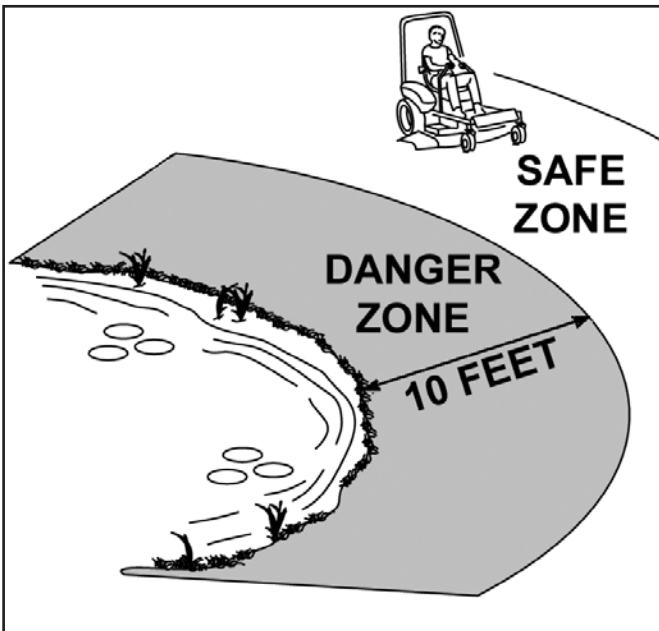

## Mowing Tips

**⚠ CAUTION** Before mowing check the area to be mowed for debris that can be removed. Objects that are fixed and cannot be removed, flag the object so a collision does not occur.

- Start by setting the Zero Turn Mower at the desired cutting height so desired result is attained. The average lawn should be cut to a height of 2-1/2" during cool seasons and 3" during hot months. For healthier, better looking lawns mow often after moderate growth has occurred.
- Grass over 6" in height should be mowed twice. Make the first cut relatively high and then mow a second time at desired height.
- Mowing results are best when the engine is a full throttle (blades spin faster) and the travel speed is low. If grass is low, travel speed can increase without affecting mowing results.
- Avoid mowing when grass is damp or wet. The mowing results can be poor and cause the wet grass to clump under the deck and stick to the underside of the mowing deck, resulting in an uneven cut.

## After Mowing is Completed

- After the Zero Turn Mower is shut down and the engine has cooled, use compressed air to clean the top surfaces of the Zero Turn Mower deck and frame. If compressed air is not available a leaf blower can be used.
- Avoid using water on top surfaces around engine and electrical components.
- Raise the Zero Turn Mower deck to its highest position and hose the underside of the Zero Turn Mower deck to remove any build up of grass clippings.

# OPERATION

## Moving Machine Manually

**NOTE:** Do not push, pull, or tow this Zero Turn Mower without first releasing the hydraulic pressure in the Integrated Transaxles.

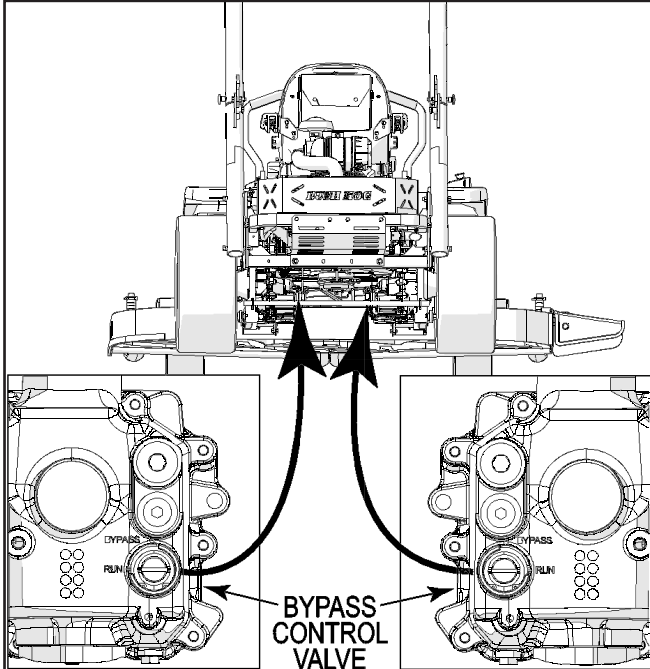

The Transaxle hydraulic fluid Bypass Control Valves are located on the front / inside of the transaxle on the underside of the Zero Turn Mower as shown above.

**CAUTION** Bypass Control Valves are close to the muffler and other HOT parts.

***NEVER attempt to manipulate the Bypass Control Valves while the engine is running.***

To prevent burn injury or physical injury turn the Zero Turn Mower off and allow for a cool down period before changing the Bypass Control Valves.

To move the zero turn mower without engine power (engine off) the Bypass Control Valve must be placed in the **BYPASS** position and parking brake off.

To relieve the hydraulic pressure on the transaxles, locate the Bypass Control Valve on the transaxle. Insert a large flat blade screw driver into the slot and turn the control 90 degrees to the **BYPASS** position. This allows the zero turn mower to be moved around without engine power.

***NOTE: The Transaxle Bypass Control Valves must be placed back to the RUN Position to enable the Zero Turn Mower to move forward or backward under its engine power.***

## Weak or Discharged Battery

If the battery is weak and will not start the engine, it should be recharged using a battery charger. Replace the battery if it will not hold a charge after recharging.

The minimum capacity battery for this Zero Turn Mower is a 12 Volt / 230 cranking amp Lawn and Garden.

**CAUTION** Lead-acid Batteries generate explosive gases. Keep sparks, flames and smoking materials away from batteries. Always wear eye protection when Jump Starting batteries.

## Jumper Cable Usage

1. Attach each end of the RED cable ends to the POSITIVE (+) terminals on each battery. Care should be taken not to short against the Zero Turn Mowers frame.
2. Connect one end of the BLACK (-) to the Fully charged battery.
3. Connect the other end of the BLACK (-) cable to a good CHASSIS GROUND on the Zero Turn Mowers frame.

## Starting the Engine

4. Operator sitting in seat. *NOTE; The Seat is equipped with an operator presence switch and will not start if operator is not sitting in the seat!*
5. Raise the Zero Turn Mower deck to the transport position (highest cutting setting).
6. Disengage the PTO Switch.
7. Engage the Parking Brake.
8. Steering Levers in the Neutral Lock position.
9. Move Throttle Control to middle position.
10. Pull Choke Up. (On cold starts)
11. Enter Console Un-Lock Code.
12. Press Start/Stop Button.

## Removing Jumper Cables

13. Disconnect the BLACK cable from the chassis ground first then from the Zero Turn Mowers battery.
14. Remove the RED cable from the Zero Turn Mowers battery and then the jumper battery.





# **TRANSPORTING SECTION 5**



# TRANSPORTING

## Transporting the Zero Turn Mower

Transport Zero Turn Mower on a heavy duty trailer that is adequate to handle the size and weight of the Zero Turn Mower. Be sure the trailer has all the necessary brakes, lighting and reflective markings required by law.

**WARNING** Never drive this Zero Turn Mower on public streets or roadways. Driving this Zero Turn Mower on streets or roadways without proper lighting, turn signals, reflective markings or a Slow Moving Vehicle Placard can lead to death or serious injury by collision with other vehicles.

## Preparing to Transport

1. Connect the trailer to the towing vehicle. Connect all trailer safety chains and lighting harness to tow vehicle.
2. Connect trailer brakes if applicable.

## Loading the Zero Turn Mower

**CAUTION** Extreme CAUTION should be used when loading and unloading the Zero Turn Mower. Avoid sudden acceleration and deceleration while driving on the ramp and trailer bed. This could cause loss of control and tip-over.

**DANGER** Do not use narrow individual ramps on each side to load this Zero Turn Mower. Only use a full width ramp that is wider than the Zero Turn Mowers width.

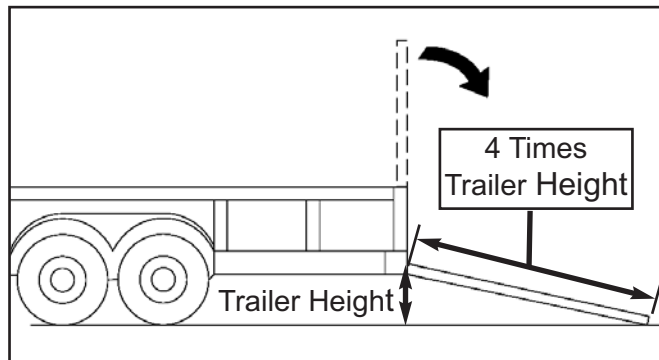

**The ramp should be 4 times longer than the height of the trailer to prevent angles above 15 degrees.**

**Loading the Zero Turn Mower at a steeper angle than 15 degrees can cause possible tip over or loss of traction resulting in death or injury. Mower components may hang up on the transition from the ramp to the trailer bed.**

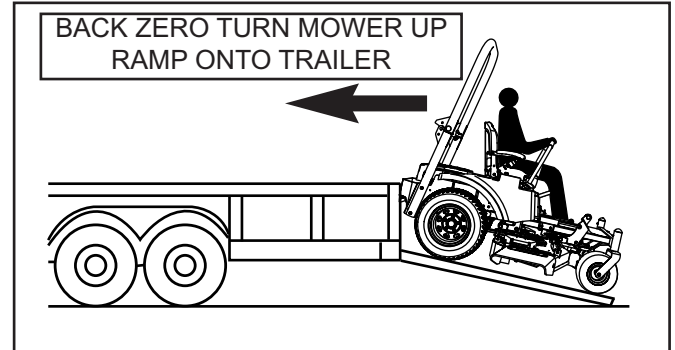

When loading the Zero Turn Mower on a trailer, back the Zero Turn Mower up the ramp and center the weight of the Zero Turn Mower over the trailer axles. After the Zero Turn Mower is loaded on the trailer shut the engine off and apply the parking brake.

## Tie Down Points

**Important** Do not rely strictly on the parking brake to transport on a trailer! Use of the tie down Straps or Chains are required for safe transport.

**CAUTION** Sudden stops or acceleration can cause the Zero Turn Mower to skid in the bed of the trailer possibly over turning the Zero Turn Mower or ejecting the Zero Turn Mower from the trailer causing death or injury to bystanders and damage to surrounding vehicles.

# TRANSPORTING

## Unloading the Zero Turn Mower

**CAUTION** *Extreme CAUTION should be used when loading and unloading the Zero Turn Mower. Avoid sudden acceleration and deceleration while driving on the ramp and trailer bed. This could cause loss of control and tip-over.*

1. Park the trailer on a level surface, then lower the ramp. **NOTE:** *If unloading must be done on a slope, position the trailer so the ramp extends up the slope not exceeding a 15 degree angle.*
2. Release the tie down straps.
3. Board the Zero Turn Mower, start the engine.
4. Release the park brake and slowly drive forward off the trailer.

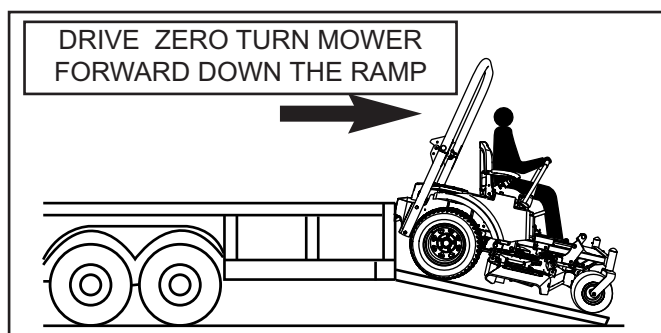

**MAINTENANCE  
SECTION 6**



# MAINTENANCE

## Recommended Regular Maintenance Schedule

Maintenance Service Interval	Maintenance Procedure
After the first 8 hours	<ul style="list-style-type: none"> <li>• Change the engine oil and oil filter.</li> <li>• Check the torque on the wheel lug nuts.</li> </ul>
After the first 100 hours	<ul style="list-style-type: none"> <li>• Change the hydraulic system filter and oil.</li> </ul>
Before each use or daily	<ul style="list-style-type: none"> <li>• Check the safety system.</li> <li>• Check the engine oil level.</li> <li>• Check the seat belt.</li> <li>• Check the rollover protection system (ROPS) knobs.</li> <li>• Clean the engine screen.</li> <li>• Inspect the blades.</li> <li>• Clean the Zero Turn Mower deck.</li> </ul>
Every 25 hours	<ul style="list-style-type: none"> <li>• Check the hydraulic oil level in the expansion tank.</li> </ul>
Every 50 hours	<ul style="list-style-type: none"> <li>• Grease the Zero Turn Mower deck idler arm.</li> <li>• Grease Blade Spindles. (5 Shots)</li> <li>• Grease Idler Pivot Point.</li> <li>• Inspect the mower belt and hydrostat drive belt for cracks and wear.</li> <li>• Lubricate the deck lift pivots.</li> </ul>
Every 100 hours	<ul style="list-style-type: none"> <li>• Change the engine oil (more often in dirty or dusty conditions).</li> <li>• Check, clean and gap the spark plug.</li> <li>• Check and clean engine cooling fins and shrouds.</li> <li>• Grease the front caster pivots (more often in dirty or dusty conditions).</li> <li>• Lubricate the caster wheel hubs.</li> <li>• Check and Clean Spark Arrestor.</li> </ul>
Every 200 hours	<ul style="list-style-type: none"> <li>• Change the engine oil filter.</li> </ul>
Every 250 hours	<ul style="list-style-type: none"> <li>• Replace the primary air filter (more often in dusty or sandy conditions).</li> <li>• Check the safety air filter.</li> </ul>
Every 400 hours	<ul style="list-style-type: none"> <li>• Change the hydraulic system filter and oil.</li> </ul>
Every 500 hours	<ul style="list-style-type: none"> <li>• Replace the safety air filter.</li> <li>• Replace the fuel filter (more often in dirty or dusty conditions).</li> <li>• Adjust the caster pivot bearing.</li> <li>• Check the electric clutch.</li> </ul>
Monthly	<ul style="list-style-type: none"> <li>• Check the battery charge.</li> </ul>
Yearly	<ul style="list-style-type: none"> <li>• Check the torque on the wheel lug nuts.</li> </ul>
Before placing in storage	<ul style="list-style-type: none"> <li>• Paint chipped surfaces.</li> <li>• Check all maintenance procedures listed above before storage.</li> <li>• Clean The Underside of the mowing deck.</li> </ul>

# MAINTENANCE

## Lubrication

Proper lubrication at specified intervals will increase the life of the Zero Turn Mower. Greasing more frequently where conditions are extremely dusty or sandy is recommended.

## Lubrication Points on the Zero Turn Mower Power Unit

The Zero Turn Mower Power Unit has 6 grease point locations, 3 on the left side and 3 on the right side (Left Side Shown, corresponding points are on the Right Side).

## **GREASE TYPE: No 2 Lithium or Molybdenum**

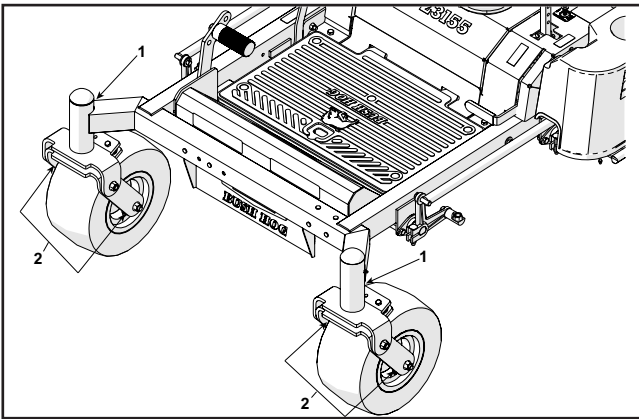

1. Grease the Front Castor Pivots every 100 hours and more frequently in dusty or sandy conditions.
2. Grease the Castor Wheels at the hubs (2 fittings on each hub) every 50 Hours and more frequently in dusty or sandy conditions.

## Lubrication Points on the Zero Turn Mower Deck

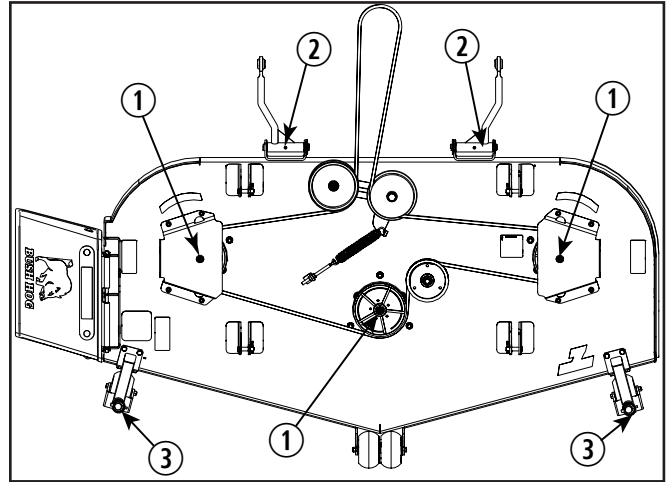

The Zero Turn Mower Deck has 7 grease points. 3 points on the Blade Spindles, 2 points on the Pusher Bars and 2 points on the Castor Wheels.

## **GREASE TYPE: No 2 Lithium or Molybdenum**

1. 5 shots of grease every 50 hours at the Blade Spindles.
2. 5 shots of grease every 50 hours at the Pusher Bar-connection.
3. 2 shots of grease every 50 hours at the Castor Wheels.

## Engine Maintenance

The Bush Hog Series HDZ Zero Turn Mowers are offered with 2 different engine manufactures, Kawasaki and Kohler. Maintenance procedures vary from each manufacturer.

***Operator / Maintenance manuals are available online as a free download from each engine manufacturer.***

Bush Hog recommends following the Engine manufacturers maintenance schedules for each manufacturer's engine model.

***See links listed on next page for downloading the Engine Manual for your Zero Turn Mower.***



# MAINTENANCE

## Mower Model ....Engine Series Number

HDZ3155FX4 .....Kawasaki FX921  
HDZ3161FX4 .....Kawasaki FX921  
HDZ3173FX4 .....Kawasaki FX921  
HDZ3355ECV4 .....Kohler Command Pro EFI  
HDZ3361ECV4 .....Kohler Command Pro EFI  
HDZ3373ECV4 .....Kohler Command Pro EFI  
HDZ3855ECV4 .....Kohler Command Pro EFI  
HDZ3861ECV4 .....Kohler Command Pro EFI  
HDZ3873ECV4 .....Kohler Command Pro EFI

Locate your Mower Model Number and then go to the Engine Manufacturer's website and navigate to the manual needed. Follow links listed below, listing the engine series when prompted.

### KAWASAKI ENGINES:

[www.kawasakinesusa.com](http://www.kawasakinesusa.com)

go to [Parts and Support](#) tab  
go to [Manuals](#) in dropdown  
go to [Series](#) and choose FX Series  
choose the FX850V or FX921V Manual  
Manual from dropdown.

### KOHLER ENGINES

[www.kohlerengines.com/manuals](http://www.kohlerengines.com/manuals)

go to [Manuals and Maintenance](#)  
go to [Owners & Service Manuals](#)  
enter engine model number under [I know my model number](#) (CV752-3011)  
Under Manuals select [Owners](#)  
Select Language (English)

## Checking Engine Oil Level

**NOTE: Check oil level when engine is cold.**

Engine oil should be checked before each use or daily.

Follow the procedures for checking oil as instructed by the engine manufacturers manual which applies to your Zero Turn Mower.

## Changing the Engine Oil and Oil Filter

**NOTE: It is recommended after the first 8 hours of usage the oil and filter be changed.**

Follow the procedures for changing oil and oil filter as instructed by the engine manufacturers manual which applies to your Zero Turn Mower.

The engine manufacturers manual will provide the recommended service intervals, oils, amount required and filters required when changing oil.

**Dispose of the used oil at a recycling center.**

## Servicing the Air Cleaner

### Service Intervals:

Every 250 hours replace the primary Air Filter (more often in dusty or sandy conditions).

Check the Safety Filter every 250 hours and replace every 500 hours of usage.

Follow the procedures for changing air filter as instructed by the engine manufacturers manual which applies to your engine.

# MAINTENANCE

MAINTENANCE

## Servicing the Battery

This Zero Turn Mower is equipped from the factory with a maintenance free battery that does not need servicing. However, if the Zero Turn Mower is not being used for an extended period or placed in storage, disconnect the Black (ground) cable from the battery. Periodic charging with automotive battery charger is recommended and will extend the battery life.

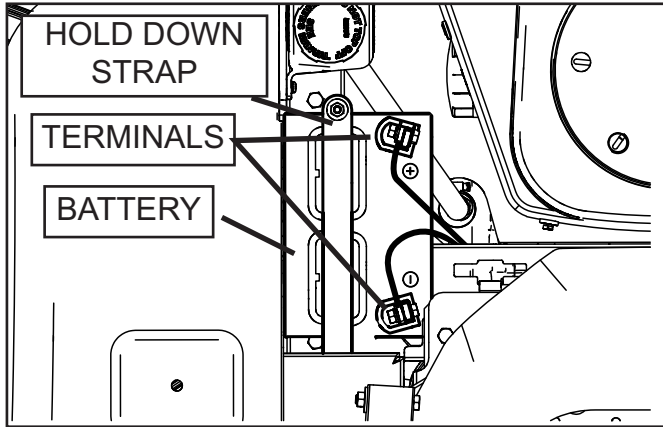

**CAUTION** Always wear eye protection when working with batteries!

The battery is located on the right hand side behind the seat.

**WARNING** DO NOT short across battery terminals by allowing a wrench or any other metal object to come in contact with both terminals at the same time.

**WARNING** DO NOT allow a wrench to come in contact with any part of the Zero Turn Mowers frame when working with the POSITIVE (+) terminal of the battery.

### • Keep Battery and Terminals Clean. Cleaning battery and terminals

1. Disconnect the BLACK battery cable (ground) first and then the RED (Positive) battery cable.
2. Remove the nut and washer on the Hold Down Strap, then remove the Hold Down Strap. Remove the battery.
3. Rinse the battery with plain water and dry.

4. Clean the terminals with a wire brush removing all corrosion and coat the terminals with a lite coat of battery terminal grease.
5. If corrosion is present on the cable ends clean the corrosion from them and place a lite coat of battery terminal grease to them. If the cable ends are severely damaged, replace the cables.
6. Re-install battery and cable in reverse order of removal.

## Replacing the Battery

1. Disconnect the BLACK battery cable (ground) first and then the RED (Positive) battery cable.
2. Remove the nut and washer on the Hold Down Strap, then remove the Hold down Strap and remove the old battery.
3. *Do Not install battery cables that show signs of corrosion to a new battery.* If corrosion is present on the cable ends, clean the corrosion from them and place a lite coat of battery terminal grease to them. If the cable ends are severely damaged, replace the cables.
4. Place the new battery in it's proper location.
5. Re-install the Hold Down Strap and fasteners.
6. Attach the RED (positive) cable to the POSITIVE (+) terminal on the battery.
7. Attach the BLACK (ground) cable to the NEGATIVE (-) terminal of the battery.
8. Check all connections to be sure they are tight. Do not over tighten.

# MAINTENANCE

## Safety System

The Safety System of this Zero Turn Mower is designed to prevent starting or driving the Zero Turn Mower under the following conditions.

### **The engine will only start when:**

- The Zero Turn Mower PTO Switch is in the down position (Blades disengaged).
- Both Steering Levers are in the Neutral Lock Position.
- The Parking Brake is on.
- Operator in seat.

Make periodic checks of the Safety System by attempting to start the engine when one of these conditions are not met.

If the engine starts when one of these conditions are not met, shut the Zero Turn Mower down and repair the safety system before using the Zero Turn Mower again.

Check to be sure the engine stops when the operator leaves the seat when the Parking brake is OFF.

Check to be sure the engine stops when the Zero Turn Mower blades are engaged and the operator leaves the seat.

Check to be sure that engine stops if the Steering Levers are moved from the Neutral Lock position with the Parking Brake in the on position.

## Parking Brake

***The Zero Turn Mower must be standing still when Parking Brake is applied.***

The Parking Brake is designed to hold the Zero Turn Mower in place when all forward or reverse motion has stopped.

**NOTE: Applying the parking brake while in forward or reverse travel and the Steering Levers in the operating position will stop the engine and could do possible damage to the Hydrostat Drives.**

## Parking Brake Adjustment



Adjusting the Parking Brake Linkage will require working under the Zero Turn Mower. Before working under the Zero Turn Mower chock the wheels so the machine cannot move.

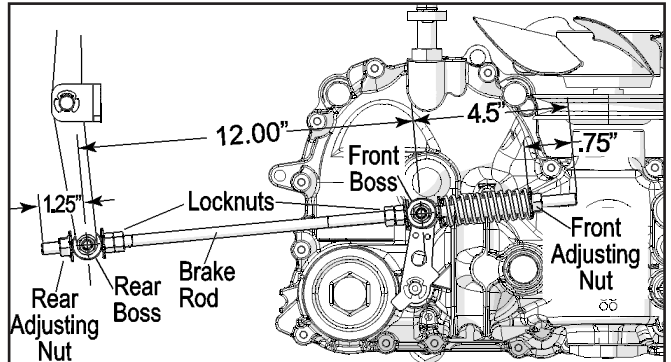

1. Release the Parking Brake.
2. Loosen the Rear Adjusting Nut, Front Adjusting Nut and the Locknuts.
3. Adjust the Rear Boss so the center is 1.25" from the end of the Brake Rod. Tighten the Rear Adjusting Nut and Locknuts against the Rear Boss to maintain this location.
4. Adjust the distance between the Rear Boss and the Front Boss so the distance is 12" between centers.
5. The distance from the center of the Front Boss to the end of the Brake Rod should now measure 4.5".
6. Turn the Front Adjusting Nut and Flatwasher against the spring until the spring side Flatwasher is .75" from the end of the Brake Rod.
7. Tighten the Locknuts against the Front Boss.

## Tire Pressure

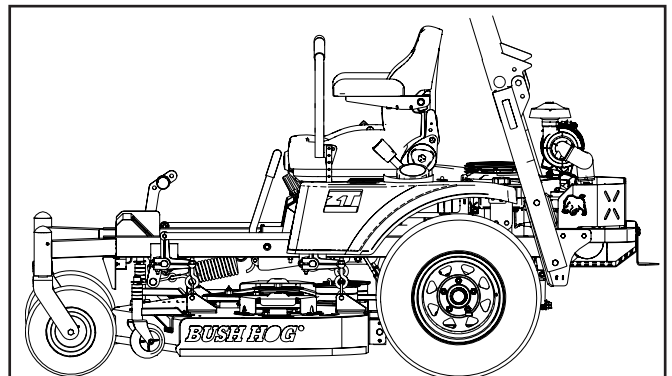

All tire pressure should be at  
15psi / 103kPa / 1 bar

# MAINTENANCE

MAINTENANCE

## Caster Wheels

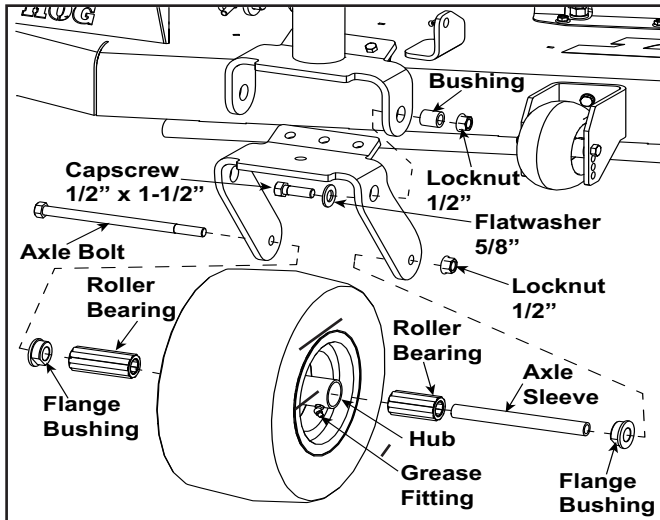

The Caster Wheels should be checked after every 200 hour of operation. Check that the wheels rotate freely on their axles. Check for excessive play on the Axle bolt and bearings.

If necessary remove the Caster Wheel from the yoke and disassemble the Wheel. Check the Axle Sleeve and Roller Bearings for excessive wear and replace if needed.

### To Disassemble:

1. Remove Axle Bolt and Nut.
2. Remove Wheel from yoke.
3. Remove Axle Sleeve.
4. Tap the Flange Bearings out of the hub.
5. Remove the Roller Bearings.
6. Clean Roller Bearings and Axle Sleeve removing old grease.
7. Clean the tube in the Hub of all old grease buildup.

### To Reassemble:

1. Place the Roller Bearings into the Hub.
2. Re-insert the Flange Bearings into the Hub.  
**NOTE:** The flat area on the Flange Bearing must be positioned so it is beneath the grease fitting in the hub tube when installed.

3. Insert the Axle Sleeve through the Hub into the Flange Bearings and Roller Bearings.
4. Put 10 shots of grease in both fittings on the Hub. Use No 2 Lithium or Molybdenum grease.
5. Place the Wheel back in the yoke, insert the Axle Bolt, apply the Axle Nut and torque to 75 ft. lbs.

## Anti-Scalp Rollers

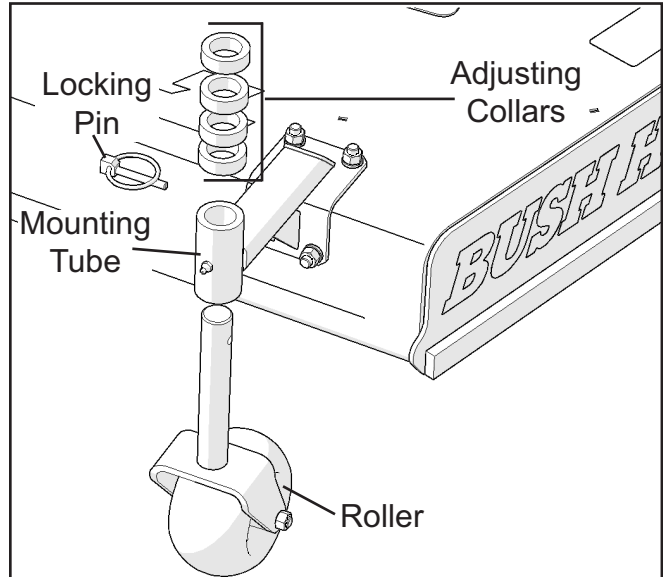

**NOTE:** All adjustments to Anti-Scalp Rollers should be made with the Zero Turn Mower on a flat level surface.

Anti-Scalp rollers should not be adjusted to support the Zero Turn Mower deck. Supporting the Zero Turn Mower deck on the Anti-Scalp rollers may damage the deck.

Adjust the Anti-Scalp rollers so they are slightly off the ground when the deck is set at the desired cutting height.

Adjustments are made by placing adjusting collars between the roller and the mounting tube to lower the roller or by placing the adjusting collars on top of the mounting tube to raise the roller.

Fasten in place by placing the Locking Pin through the hole in the top of the Roller shaft.

Check the Rollers and Axle Bolt for wear often and replace when necessary.

# MAINTENANCE

## Mower Deck V-Belts

Mower deck V-Belts should be checked every 100 hours of usage and more often under heavy usage.

Inspect belts for severe cracking and large nicks.

**NOTE:** Belts will show small cracks under normal operation.

## Mower Deck Belt Removal and Installation

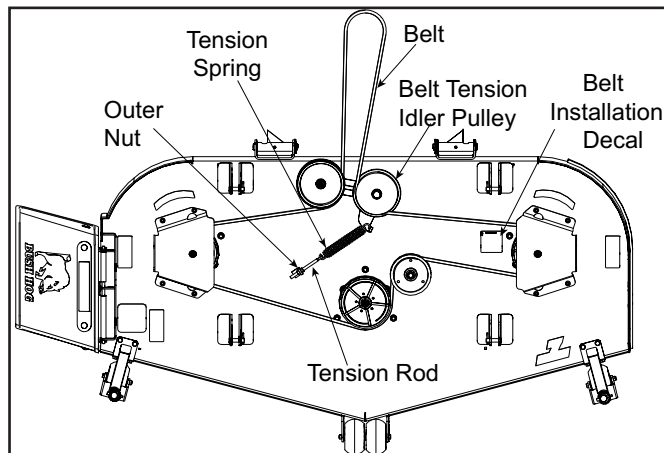

### Mower Deck Belt Removal

1. Park the Zero Turn Mower on a flat level surface and set the parking brake.
2. Lower the deck to its lowest cutting position.
3. Remove the foot plate and outer belt shields.
4. Let the tension off the Belt Tension Idler Pulley by backing off the outer nut on the Tension Rod until the belt has enough slack to be removed from the pulleys.
5. Remove the belt from the deck pulleys.
6. At the rear of the Zero Turn Mower remove the belt from the clutch pulley. Then remove the belt from under the Zero Turn Mower.

### Mower Deck Belt Installation

For further reference, there is a Decal (Belt Installation Diagram) applied to the Deck.

1. Place the belt on the deck pulleys as illustrated above.
2. Route the belt to the clutch pulley and install. belt routing is correct.

3. Check to be sure there are no twist in the belt and the belt routing is correct.
4. Tighten the Outer Nut to apply tension to the Belt Tensioner Idler Pulley.
5. Before re-installing the foot plate the newly installed belt tension should be adjusted.

### Adjusting the Mower Deck Belt

6. To adjust the belt tension, the spring should measure seven (7-1/2") inches from the ends of loops, as shown in the illustration. This is achieved by turning the Adjusting Nuts on the Tension Rod against the Bracket.
5. When desired belt tension is achieved, tighten the two nuts against the bracket.
6. Re-Install the outer belt shields and foot plate.

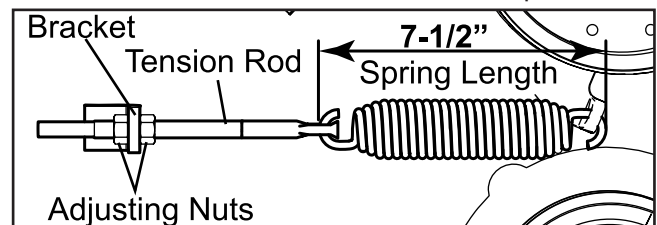

# MAINTENANCE

MAINTENANCE

## PUMP BELT

**CAUTION** Servicing the Pump Belt will require the back end of the Zero Turn Mower to be elevated to gain access to the belt area.

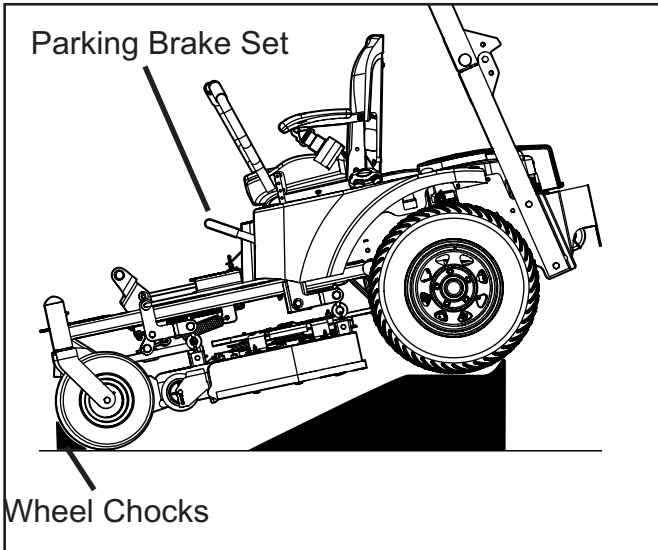

**DANGER** Always set the Parking Brake and use wheel chocks on the front caster wheels before working under the Zero Turn Mower.

Automotive ramps will allow enough clearance to access the pump belts from the underside of the Zero Turn Mower.

If raising the Zero Turn Mower with an overhead hoist, raise the Zero Turn Mower and place jackstands under the Zero Turn Mower. Lower Zero Turn Mower down on the jackstands and chock the front wheels.

### Pump Belt Removal

1. Remove the foot plate to access the Mower Deck Belt.
2. The Mower Deck Belt must be removed from the Clutch prior to working with the Pump Belt. Refer to **(Mower Deck Belt Removal)** steps 4 and 6.
3. Remove the Clutch Stop.
4. Release the tension on the Idler Pulleys by backing off the Tensioner Adjusting Nuts on the Tensioner Rod.
5. Remove the Pump Belt from the clutch pulley, idler pulleys and pump pulleys.

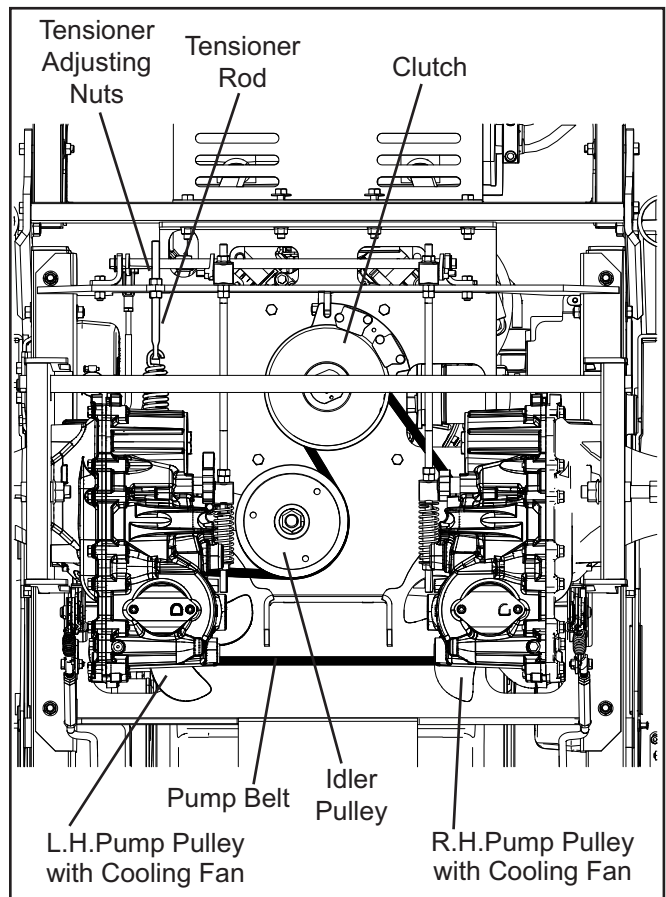
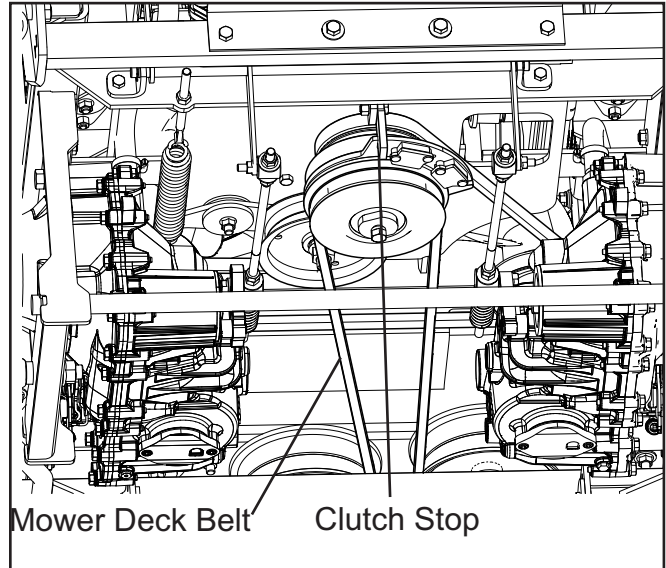

**NOTE:** The belt will need to be lifted over the cooling fans attached to the top of pump pulleys.

# MAINTENANCE

## Pump Belt Installation

1. Follow steps 1-4 of Pump Belt Removal.
2. Place the belt over the Cooling Fans and into the pulley Groove.
3. Place the belt on the Idler pulley and pull the belt back to the clutch.
4. Place the belt on the upper pulley above the Clutch.
5. Check to be sure the belt is installed in all the pulley grooves and is not twisted.
6. Tighten the belt using the Tensioner Adjusting Nuts on the Tensioner Rod. The Tensioner Rod end should be between 1-1/4" to 1-1/2" from the frame obtain the proper Belt tension.

### **DO NOT OVER TIGHTEN!**

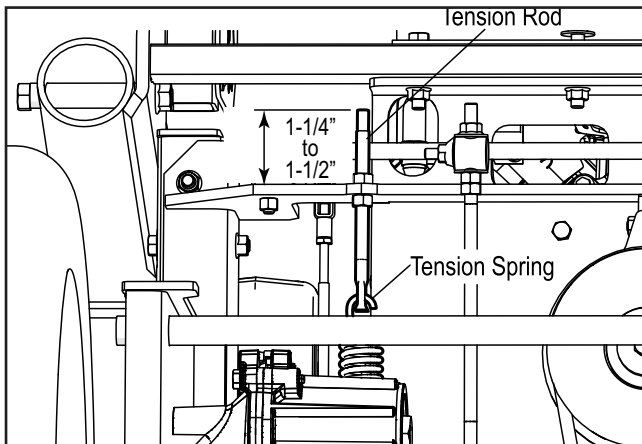

7. When desired tightness is achieved lock the Tensioner Rod position by tightening the Tensioner Adjusting Nuts.
8. Place the Mower Deck Belt back on the Clutch.
9. **IMPORTANT!** Re-Install the Clutch Stop.  
*Damage to the Clutch will result if Zero Turn Mower is engaged without Clutch Stop Installed.*
10. Adjust the Mower Deck Tension (**See Adjusting Mower Deck Belt**).
11. Re-install the foot plate.

## Cutting Blade Maintenance

Best mowing results are achieved when blades are sharp and not damaged.

Replace blades that become bent or cracked while mowing.

**WARNING** WHEN IT IS NECESSARY TO RAISE THE DECK OR MOWER FOR SERVICE OR MAINTENANCE, TO AVOID DEATH OR SERIOUS INJURY, STOP ENGINE, SET PARKING BRAKE, SECURELY SUPPORT THE DECK OR MOWER BEFORE WORKING UNDERNEATH.

## Blade Removal

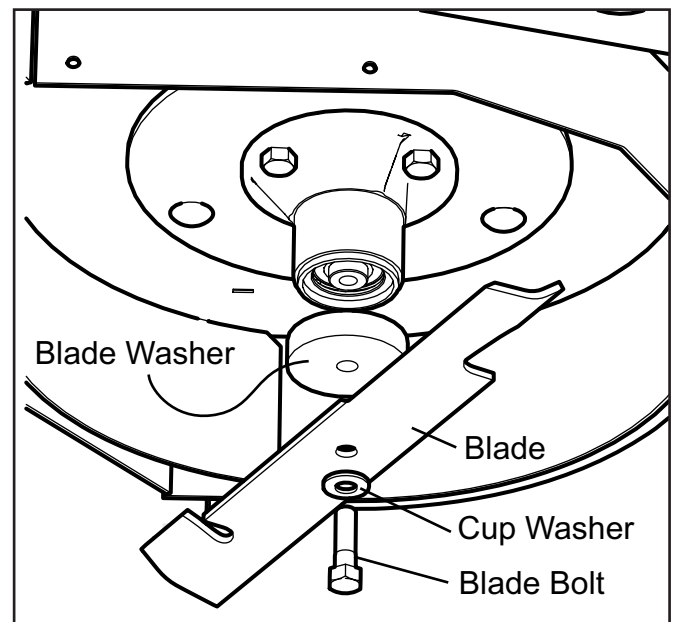

1. Lift deck and secure in raised position.
2. Remove Blade Bolt, Cup Washer, Blade and Blade Washer from shaft.

## Inspect Blades

**Blades should be discarded when worn excessively.**

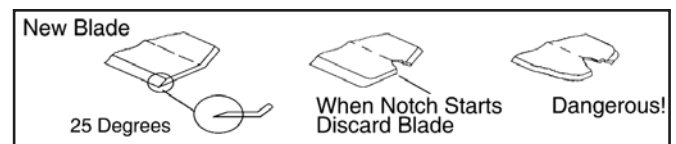

MAINTENANCE

# MAINTENANCE

MAINTENANCE

## Sharpening Blades

**WARNING** When sharpening blades wear gloves and eye protection.

1. Sharpen blade with a hand file, electric grinder or blade sharpener.
2. Grind blade at original bevel.
3. Check balance of blade by positioning the blade on a nail or blade balance pedestal.
4. Grind the blade on the end that is heavier until both sides balance.

## Installing Blades

**Important** When installing blades be sure they are installed with the cutting edge down and the uplift facing up.

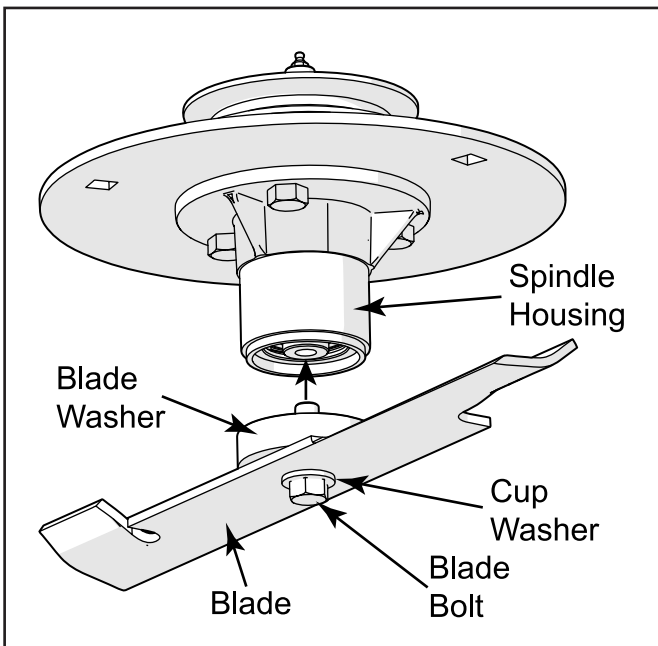

1. Place Cup Washer on the Blade Bolt (Position cup upwards) so the concave side will be against the blade.
2. Place the Blade Bolt through the blade mounting hole from the blades cutting side (Grass Side).
3. Place the upper side of the blade to the Blade Washer (Smooth Side).
4. Put the Blade Bolt in the hole of the Blade Washer and push through.
5. Install the assembly in the spindle housing and tighten the Blade Bolt to 75 ft lbs torque.

## Adjusting the Mower Deck

**Important** Check tire pressure before adjusting Mower Deck (See - **Tire Pressure**). Under inflated or over inflated tires will not allow you to properly adjust your Zero Turn Mower deck.

## Leveling the Deck

1. Park the Zero Turn Mower on a hard level surface. Turn the Zero Turn Mower off and set the parking brake.

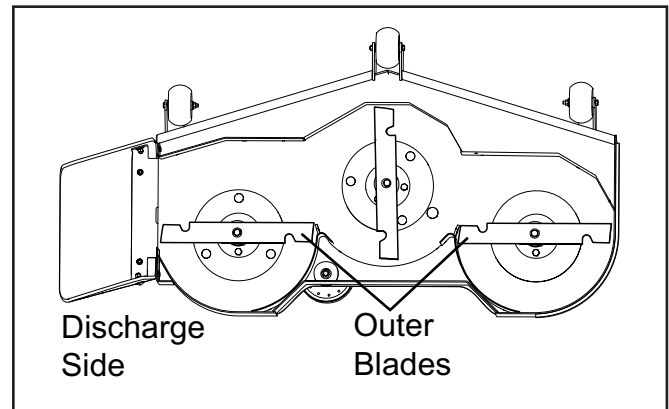

2. Rotate the outer blades so the blade tips align with the deck sides as shown above. **NOTE:** wear heavy gloves when working with blades.
3. Depress the deck lift pedal to raise the mower deck. Place the Deck Height Adjusting Pin in the 3" adjusting hole and release the pedal.
4. Measure from the blade tip to the ground level and retain this measurement. Repeat this process on the opposite side.

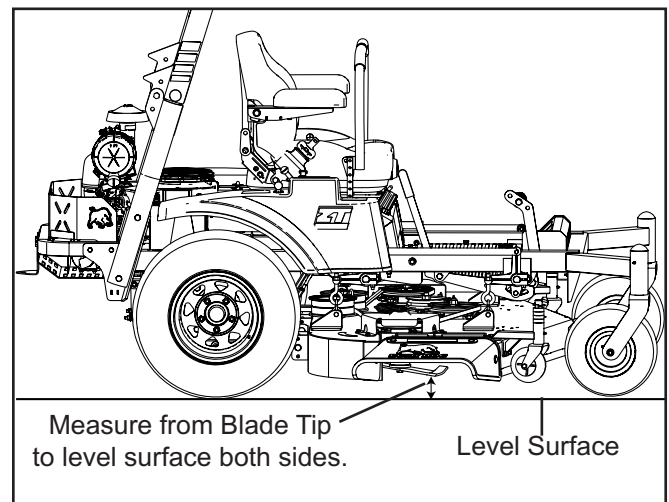



# MAINTENANCE

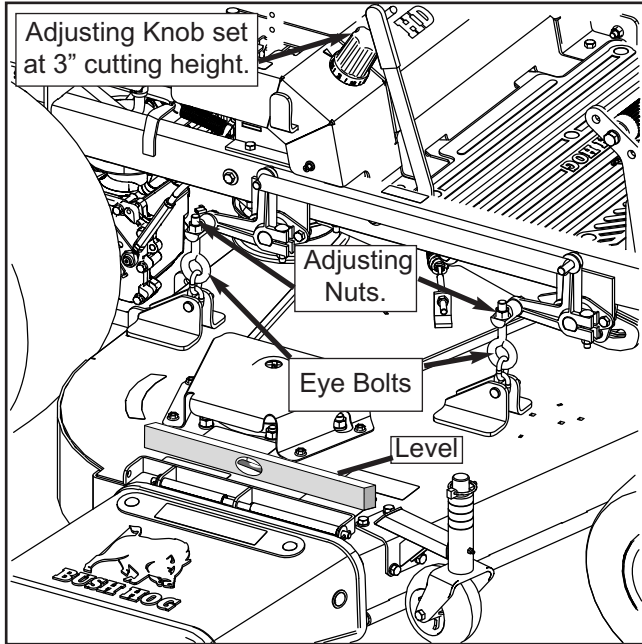

5. Adjustment is achieved by turning the Adjusting Nuts at the Rear Deck Hangers on each side of the deck until the blade tips are at the 3" position.
6. After the blade tips are at the 3" position on both sides, place a level on the top of the deck, positioned front to rear.
7. At the Front Hangers, turn the Adjusting Nuts on each side to raise or lower the deck until the deck is level. Do this procedure on both sides of the deck.
8. Once the deck is level on both sides, check the level of the deck side to side by placing the level on the front of the deck, Some minor adjustment may be necessary.
9. After the deck is level on both sides, recheck the blade tips for the 3" position. Some minor adjustment may be necessary.

## Transaxle Maintenance

This Zero Turn Mower has two Transaxles. The Transaxles have serviceable filters for ease of maintenance. To ensure fluid quality and longer life, changing the oil and filter after the initial 100 hours of Zero Turn Mower usage then in 400 hour intervals thereafter is recommended.

**NOTE:** Recommended oil is API classification of SL is recommended. A 20W-50 engine oil has been selected for use by the factory and is recommended for normal operating temperatures.

**NOTE:** Biodegradable oils are not approved for this unit as they degrade too quickly while in service.

### Fluid and Filter Change Procedure

The following procedure can be performed with the transaxle installed in the vehicle. The Zero Turn Mower must be parked on a level surface, parking brake set and bypass valve on each transaxle applied.

Allow the Zero Turn Mower to cool down before proceeding to perform maintenance.

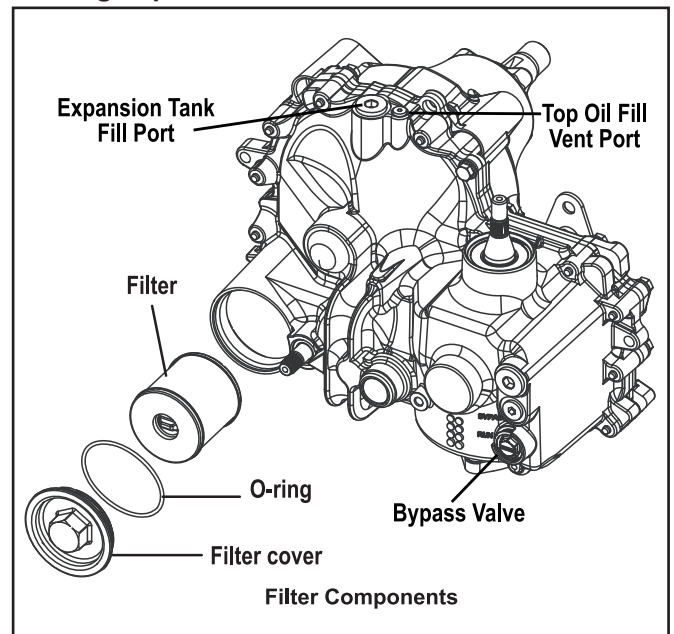

1. Place an oil drain pan (12" or more in diameter and 8 qt. capacity is optimal) beneath the oil filter. Remove the oil filter cover from the transaxle to drain the oil. Remove the O-ring from the cover and discard the O-ring. Use Bush Hog Filter Kit 50072375 (Includes "O" Ring and Filter). Two Kits required per Zero Turn Mower.

# MAINTENANCE

MAINTENANCE

2. After the oil has drained from the transaxle, remove the oil filter from the transaxle housing.
3. Install a new filter and a new O-ring onto the filter cover and install the filter cover.
4. Remove the top oil fill vent port plug and fill the transaxle with new 20W50 motor oil through the expansion tank port/fill port until oil reaches the oil fill vent port.
5. Install the top oil fill vent port plug and continue filling the system with oil until the fill line is reached in the expansion tank.

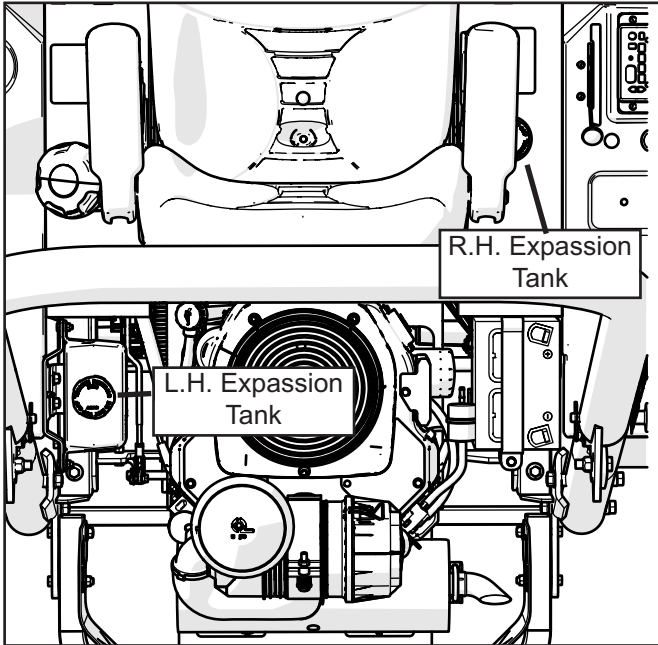

6. Drain old oil filter of all free flowing oil prior to disposal. Place used oil in appropriate containers and deliver to an approved recycling collection facility.
7. Proceed to the Purging Procedures.

## Purging Procedures

**These purge procedures should be implemented any time a hydrostatic system has been opened to facilitate maintenance or the oil has been changed.**

Due to the effects air has on efficiency in hydrostatic drive applications, it is critical that it is purged from the system.

Air creates inefficiency because its compression and expansion rate is higher than that of the oil approved for use in hydrostatic drive systems.

The resulting symptoms in hydrostatic systems may be:

1. Noisy operation.
2. Lack of power or drive after short term operation.
3. High operation temperature and excessive expansion of oil.

**Before starting, make sure the transaxle is at the proper oil level. If it is not, fill to the specifications outlined in this manual. Refer to steps 4-5 under Fluid and Filter Change Procedure**

**The following procedures are best performed with the vehicle drive wheels off the ground. Then repeated under normal operating conditions.**

**If this is not possible, then the procedure should be performed in an open area free of any objects or bystanders.**

1. Disengage the brake if activated.
2. With the bypass valve open and the engine running, slowly move the directional control in both forward and reverse directions (5 or 6 times).
3. With the bypass valve closed and the engine running, slowly move the directional control in both forward and reverse directions (5 to 6 times). Check the oil level, and add oil as required after stopping the engine.
4. It may be necessary to repeat Steps 2 and 3 until all the air is completely purged from the system. When the transaxle operates at normal noise levels and moves smoothly forward and reverse at normal speeds, then the transaxle is considered purged.

# MAINTENANCE

## Console Maintenance

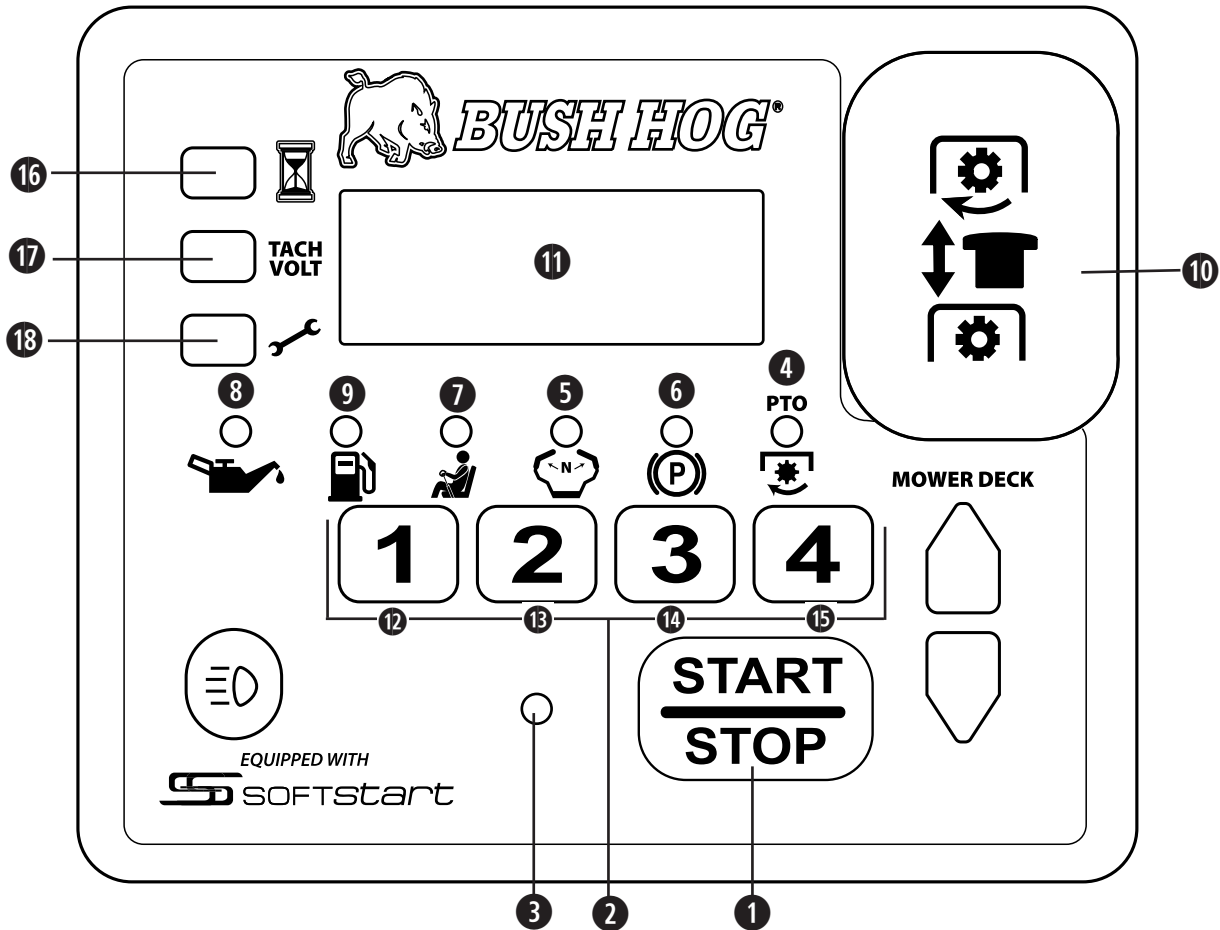

ITEM	DESCRIPTION	FUNCTION
1	Engine Start/Stop Button	Powers Engine ON / Powers Engine OFF.
2	Key Code Buttons	Powers up Console by entering Key Code and enables specific functions as starting /stopping engine, engaging PTO.
3	OK to Start Indicator Light	Glows Green when safe to start engine, Red when unsafe.
4	PTO Indicator LED	Glows Red to indicate PTO is engaged.
5	Steering Lever Indicator LED	Glows Red when Steering Levers are not in Neutral position during startup
6	Parking Brake LED	Glows Red if Parking Brake not set during startup.
7	Operator Position Indicator	Glows Red if Operator is not in seat.
8	Low Oil Indicator LED	Alerts Operator when Engine oil is low.
9	Fuel Level Indicator LED	Alerts Operator when Fuel is low.
10	PTO Switch	Engages /Disengages Mower Blades.
11	LCD Display	Indicates Hours, Service Alerts, Engine RPM, and Voltage.
12	Key Pad Button 1	Enter Functions
13	Key Pad Button 2	Enter Functions
14	Key Pad Button 3	Enter Functions
15	Key Pad Button 4	Enter Functions
16	Hour Meter	Total Accumulated Hours on Engine
17	Tach / Volt Meter	Toggles between Engine RPM and Voltage
18	Service Engine Light	Indicates when time for oil change. (Resetable)

# MAINTENANCE

## Console Maintenance

### General Care

The Console is a completely sealed instrument designed to withstand exposure to outdoor environments. Pressure washing of the console face is acceptable when water spray pressure does not exceed 2000 psi while using a 30 degree or greater nozzle tip (fan spray) at a distance no closer than 12". Oil, gasoline, chemicals and detergents spilled on the console should be wiped off immediately with a clean dry cloth.

*Never use abrasive or corrosive cleaning products on the console.*

### Bypassed or Failed Safety Interlock Switch Detection

While monitoring the safety interlocks, the console identifies interlock switches that have failed, closed, or have been bypassed closed. When the console detects a failed or bypassed switch, it slowly flashes the corresponding indicator LED and flashes "SEAT"/"BRAKE"/"DRIVE" "INTLK" "FAULT" on the LCD.

The console allows the equipment to continue operating normally for a short time after detecting a potentially faulty switch to allow the equipment to return to a service area, locking out engine operation after this time is exhausted.

To clear this error, replace or repair the faulty interlock switch and open the switch while the console is unlocked by entering your Key Code.

### Service Alerts

Service alerts remind the operator to perform specific maintenance tasks based on equipment run time. While the console is unlocked by entering your Key Code, click key code button 1 (12) once to enter service alert display, and again as needed to select the desired alert to display. The display returns to engine hour meter after 30 seconds of inactivity.

### To Reset A Service Alert:

- a. Begin with the console unlocked by entering your Key Code. The console must be unlocked to reset a service alert.
- b. Select the service alert to reset by clicking keypad button 1(12) until the LCD shows the desired service message.
- c. Press and hold keypad Service (18) for 6 seconds.
- d. Release the button when the LCD shows "00000".

### Alarms

**Low Oil Alarm** - If the oil pressure switch closes for ten seconds while the engine is running, the console displays "OIL" "PSI" on the LCD (11), flashes the low oil light (8).

**Low Voltage Alarm** - While the console is unlocked by entering your Key Code, and the system voltage is below 12.0 V for 90 seconds, the console displays "LOW VOLTS" and the current system voltage. This alarm is reset when the system voltage rises above 12.0 V or when the console goes to sleep.

**High Voltage Alarm** - While the console is unlocked by entering your key code, and the system voltage is above 15.0 V for more than 2 seconds the console displays "HIGH VOLTS" and the current system voltage. This alarm is reset when the system voltage drops below 15.0 V or when the console goes to sleep.

# MAINTENANCE

## Console Diagnostic Codes

When a fault is detected by the console it is displayed on the LCD (14) as a numeric code. Below is a chart of the error codes and potential sources.

ERROR CODE #	DESCRIPTION
10	Continuous PTO clutch current to high - check PTO clutch coil resistance.
11	Function inhibited because continuous system current to high.
12	Check battery condition and connections, check starter solenoid wiring for shorts.
13	Check battery condition and connections, check PTO and PTO wiring for shorts.
14	Check battery condition and connections, check fuel solenoid and fuel solenoid wiring for shorts.
15	Check headlight wiring for shorts
16	Check battery condition and connections, check deck motor and wiring for shorts.
17	Check battery condition and connections.
18	Check battery condition and connections, check starter and fuel solenoid and wiring for shorts.
19	Check battery connections and connections, check PTO and PTO wiring for shorts.
20	Check battery connections, check fuel solenoid and wiring for shorts.
21	Check battery connections, check headlight wiring for shorts.
22	Check battery condition and connections, check deck motor and wiring for shorts.
23	Check battery condition and connections, check all wiring for shorts.
24	Excessive system current,
25	Check PTO current.
26	Excessive system current.
27	Excessive system current, check headlights.
28	Excessive system current, check binding deck lift or problem with motor.
29	Excessive system current.
30	Console internal fault.
39	Console internal fault, some or all power functions disabled.
40	Console internal fault.
41	Console internal fault.
42	Check PTO wiring.
43	Check PTO wiring.
44	Low PTO on current, check PTO wiring and connections.
45	Console internal fault.

# MAINTENANCE

## \*SPARK ARRESTOR MAINTENANCE

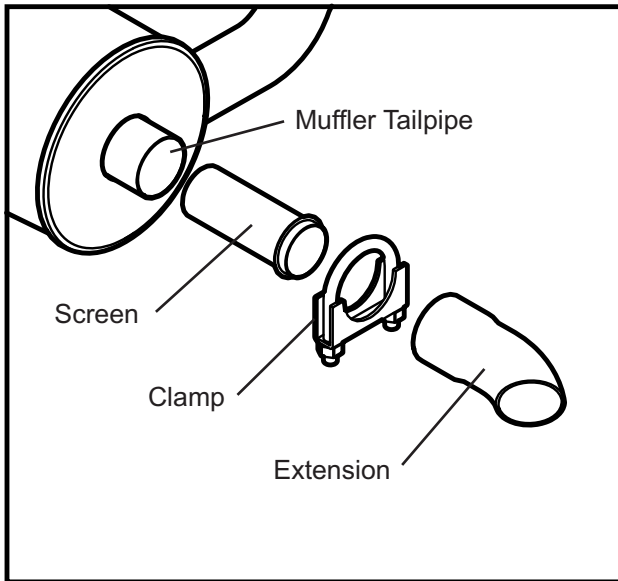

\*This unit is Approved for use on U.S. Forest Service Lands.

MAINTENANCE

### Maintenance



**Wait until the muffler is cool before performing any maintenance.**

**SPARK ARRESTOR SCREEN** should be inspected every 100 hours of engine usage.

1. Loosen the two nuts on the clamp and slide clamp off, over the tailpipe extension.
2. Remove tailpipe extension. The extension may have become tight to the muffler as a result of the crimping action of the clamp. Pliers may be required for extra grip when twisting the extension off.
3. Slide the Spark Arrestor Screen out of the muffler and shake the screen to remove the built up soot and carbon. The amount of carbon collected will vary with fuel used, air quality, engine age and condition. (A soft metal brush may be required to fully clean the screen.)
4. Carefully inspect the screen for any tears, rips, or any other damage which will prevent the screen from operating properly. Replace screen if damaged.
5. Re-install the cleaned and inspected screen.

### Installation

1. Insert the screen into the tailpipe on the muffler until the retaining ring is against the tip of the tailpipe.
2. Install the extension over the tailpipe, The extension should be "snug" fit.
3. Slide the clamp over the extension until it circles the expanded section of the extension where the tailpipe and extension overlap. Tighten the two clamp bolts evenly.

# **STORAGE SECTION 7**





# STORAGE

## Winter Storage

At the end of the mowing season, or when it will not be in use for more than 30 days, the Zero Turn Mower should be readied for storage.

Fuel allowed to stand for long periods of time (30 days or more) can leave sticky residues that can plug the carburetor and disrupt engine function.

Fuel stabilizers are an acceptable option as regards to the sticky residues that can occur during storage.

Add stabilizer to the fuel in the tank and in the storage container.

Always use the mixing ratios specified by the manufacturer of the stabilizer.

Run the engine for at least 10 minutes after adding the stabilizer so that it reaches the carburetor. Do not empty the fuel tank and the carburetor if you have added stabilizer.



**WARNING** Never store an engine with fuel in the tank indoors or in poorly ventilated spaces where fuel vapor can come in contact with open flames, sparks, or a pilot light such as in a boiler, hot water tank, clothes dryer, etc. Handle the fuel with care. Gasoline Fumes are very flammable and can cause serious personal injury and property damage. Drain the fuel into an approved container outdoors and store far away from open flame or sources of ignition. Never use gasoline for cleaning. Use a degreaser and warm water instead.

### Preparing the Machine for storage:

1. Thoroughly clean the Zero Turn Mower, especially under the Zero Turn Mower deck. Touch up damage to the paint and spray a thin layer of oil on the underside of the Zero Turn Mower deck to avoid corrosion.
2. Inspect the Zero Turn Mower for worn or damaged parts and tighten any nuts or screws that may have become loose.
3. Change the engine oil; dispose of properly.
4. Empty the fuel tanks or add a fuel stabilizer. Start the engine and allow it to run until the carburetor is drained of fuel or the stabilizer has reached the carburetor.
5. Remove the spark plug and pour about a tablespoon of engine oil into the cylinder. Turn over the engine so that the oil is evenly distributed and then re-install the spark plugs.

6. Lubricate all grease fittings, joints, and axles.
7. Remove the battery. Clean, charge, and store the battery in a cool place, but protect it from direct cold or freezing.

8. Store the Zero Turn Mower in a clean, dry place and cover it for extra protection.

## New Season Preparation

Before starting the mower following post season storage, the following service is required:

**Important** *Always check that fresh oil has been added to Zero Turn Mower. If oil is drained at season's end and not replaced, engine damage will result.*

1. Clean Zero Turn Mower, removing trash and dirt accumulation.
2. Check engine oil and hydraulic oil levels.
3. Fill fuel tank with fresh fuel. Run Zero Turn Mower at half speed for 5 minutes, checking operation of steering control lever. Stop engine and check for oil leaks, loose fittings.
4. Tighten any bolts that have loosened and make sure all hair pins, cotter pins and clevis pins are in place.
5. Check that all safety shields are in place and secure and review safety precautions listed in this manual.
6. Check Mower belt and drive belt for damage or severe cracking and replace if needed.
7. Check Mower blades for sharpness and damage. Replace or sharpen if needed.
8. Check and inflate tires to 15 psi / 1 bar / 103 kPa.
9. Install fully charged battery and attach the battery cables.
10. Check Safety system startup. Refer to **Safety System** in the **Maintenance Section**.
11. Refer to engine manual for more information.

**Important** *If Service Parts are required after New Season Preparation check is completed use only Genuine Bush Hog Parts. The use of "Will Fit" parts may reduce Zero Turn Mower performance, void warranty and present a safety hazard.*



# **TROUBLE SHOOTING**

## **SECTION 8**



# TROUBLE SHOOTING

PROBLEM CAUSE	PROBLEM CAUSE
<p><b>ENGINE WILL NOT START</b></p> <ul style="list-style-type: none"> <li>Battery Dead</li> <li>PTO Switch Engaged</li> <li>Steering Levers not in Neutral Lock Position</li> <li>Parking Brake Not Set</li> <li>Contamination in Carburetor or Fuel Line</li> <li>Clogged Fuel Filter</li> <li>Ignition System Faulty</li> </ul> <p><b>STARTER DOES NOT TURN OVER</b></p> <ul style="list-style-type: none"> <li>Dead Battery</li> <li>Poor contact of the battery cable connection</li> <li>Blown Fuse</li> <li>Faulty Starter</li> <li>Parking Brake not set.</li> <li>Steering Levers not in the Neutral Lock position.</li> <li>Clutch is engaged.</li> </ul> <p><b>BATTERY NOT CHARGING</b></p> <ul style="list-style-type: none"> <li>Poor contact of the battery cable connection</li> <li>Charging Lead Disconnected</li> <li>Faulty engine charging system</li> </ul> <p><b>ENGINE RUNS ROUGH</b></p> <ul style="list-style-type: none"> <li>Faulty Carburetor</li> <li>Clogged Fuel Filter</li> <li>Water in fuel</li> <li>Fuel tank near empty</li> <li>Rich Fuel mixture or fuel air mixture</li> <li>Wrong type fuel</li> <li>Clogged air filter</li> <li>Fouled Spark Plug</li> <li>Clogged ventilation valve fuel cap</li> </ul> <p><b>ENGINE POWER IS WEAK</b></p> <ul style="list-style-type: none"> <li>Clogged Air Filter</li> <li>Fouled Spark Plugs</li> <li>Carburetor out of adjustment</li> <li>Air trapped in hydraulic system</li> </ul> <p><b>MACHINE VIBRATES</b></p> <ul style="list-style-type: none"> <li>Loose Blade or Blades</li> <li>Blades not balanced</li> <li>Engine mount bolts loose</li> </ul>	<p><b>ENGINE OVERHEATS</b></p> <ul style="list-style-type: none"> <li>Clogged air intakes or cooling fins</li> <li>Engine overloaded</li> <li>Low Oil</li> <li>Contamination in fuel line</li> <li>Fouled Spark Plugs</li> </ul> <p><b>MACHINE MOVES SLOW, UNEVEN, NOT AT ALL</b></p> <ul style="list-style-type: none"> <li>Park Brake engaged</li> <li>Bypass linkage engaged</li> <li>Pump Belt for transmissions loose or has come off</li> <li>Air in hydraulic system</li> </ul> <p><b>MOWER DECK NOT ENGAGING</b></p> <ul style="list-style-type: none"> <li>Drive Belt has come off</li> <li>Mower Belt tension needs adjusting</li> <li>Faulty electromagnetic clutch</li> <li>Connection to clutch is loose or off</li> <li>Faulty PTO switch</li> <li>Blown Fuse</li> </ul> <p><b>TRANSAXLE LEAKING OIL</b></p> <ul style="list-style-type: none"> <li>Damaged seals, housing or gaskets</li> <li>Air trapped in hydraulic system</li> </ul> <p><b>UNEVEN MOWING</b></p> <ul style="list-style-type: none"> <li>Air pressure not equal in all tires</li> <li>Bent blade or blades</li> <li>Mower Deck not adjusted level</li> <li>Blades are dull</li> <li>Driving speed to fast</li> <li>Grass too high</li> <li>Grass build up under Zero Turn Mower deck</li> </ul>



# **TECHNICAL DATA**

## **SECTION 9**





# TECHNICAL DATA

## MAIN WIRING HARNESS ASSEMBLY

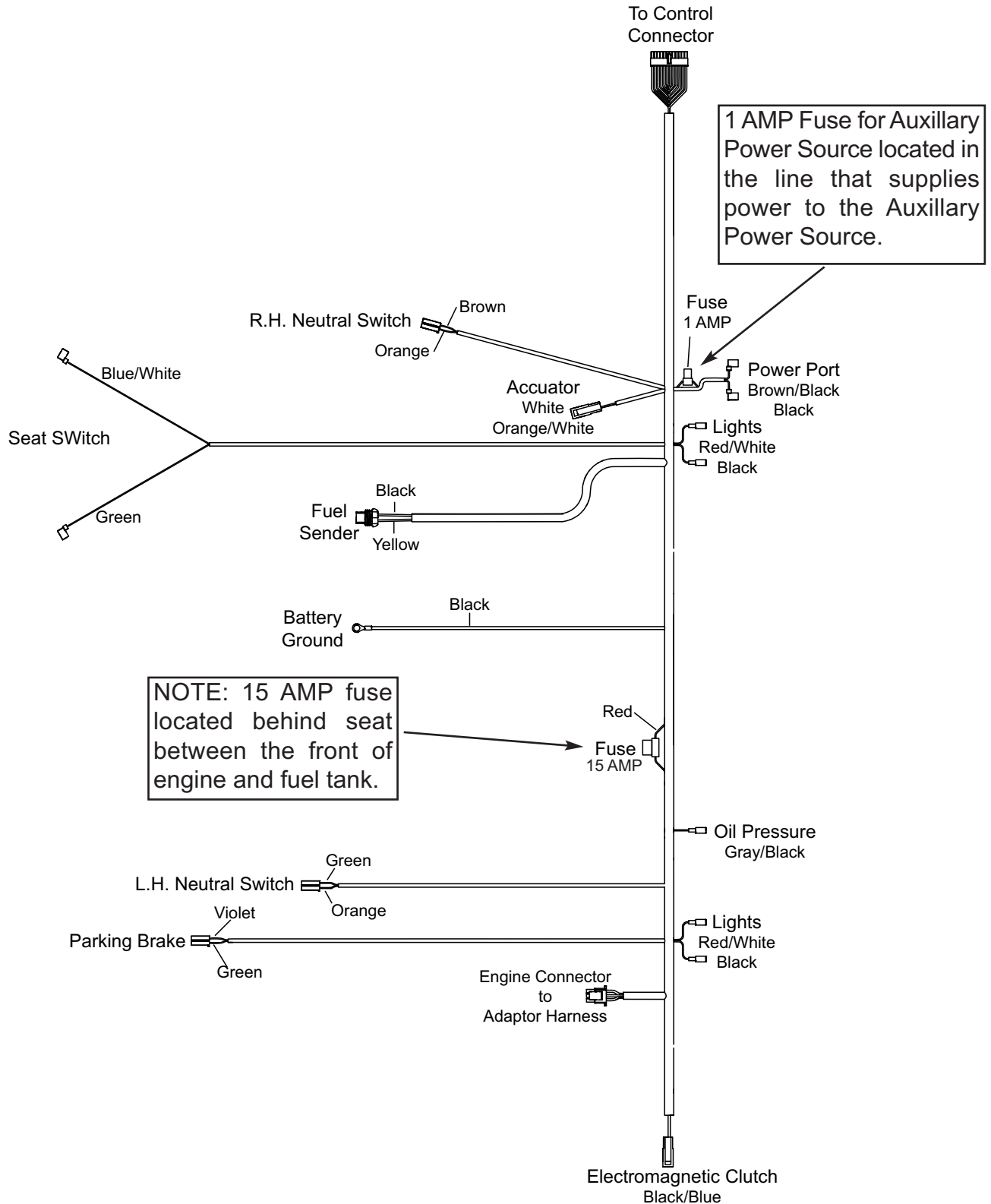

TECHNICAL

# TECHNICAL DATA

## TECHNICAL

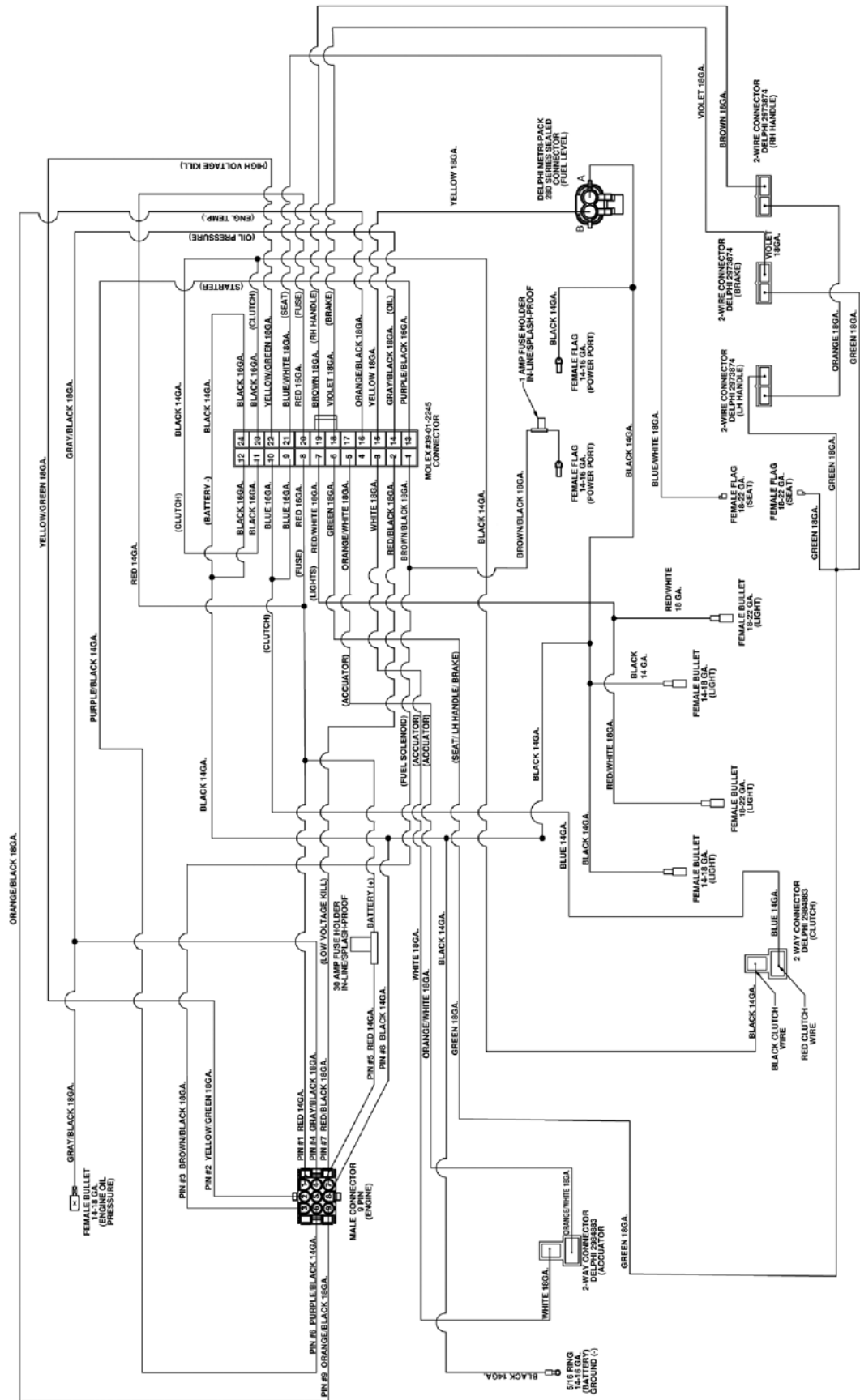

## MAIN WIRING HARNESS SCHEMATIC

# TECHNICAL DATA

50077206

## ENGINE ADAPTOR HARNESS for KAWASAKI ENGINES

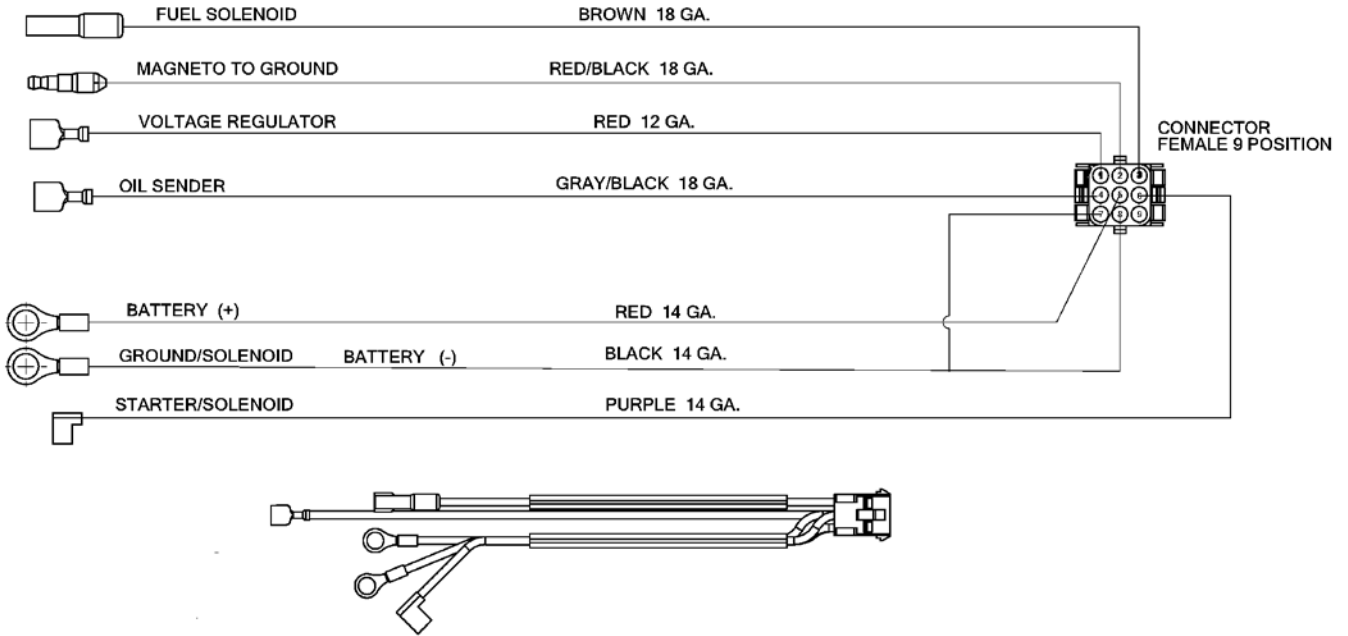

TECHNICAL

# TECHNICAL DATA

50076065

## ENGINE ADAPTOR HARNESS for KOHLER ENGINES

TECHNICAL

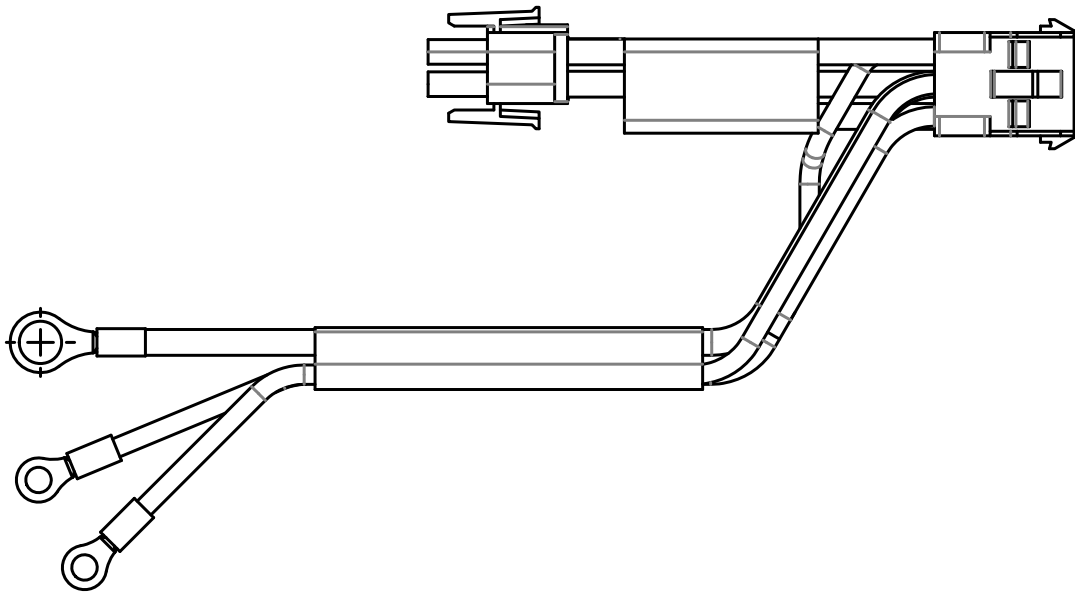
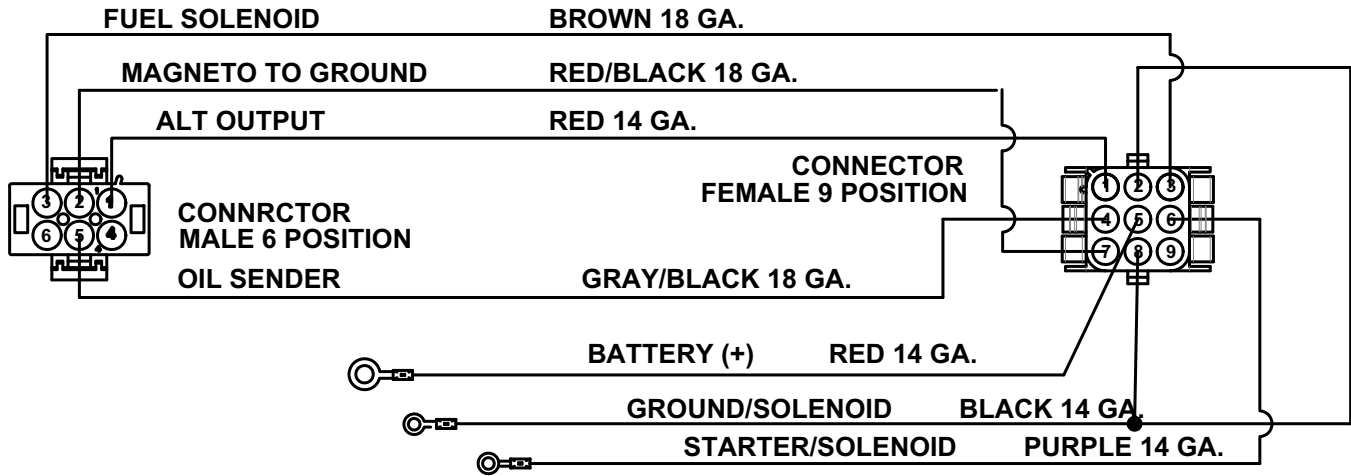

# TECHNICAL DATA

## TORQUE SPECIFICATIONS

Proper torque for American fasteners used on Bush Hog equipment.  
Recommended Torque in Foot Pounds (Newton Meters).\*

### AMERICAN Bolt Head Markings

SAE Grade 2  
(No Dashes)

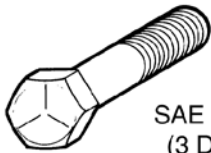

SAE Grade 5  
(3 Dashes)

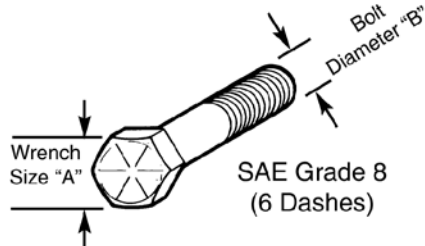

SAE Grade 8  
(6 Dashes)

WRENCH SIZE (IN.) "A"	BOLT DIAMETER (IN.) "B" AND THREAD SIZE	SAE GRADE 2	SAE GRADE 5	SAE GRADE 8
7/16	1/4 - 20 UNC	6 (7)	8 (11)	12 (16)
7/16	1/4 - 28 UNF	6 (8)	10 (13)	14 (18)
1/2	5/16 - 18 UNC	11 (15)	17 (23)	25 (33)
1/2	5/16 - 24 UNF	13 (17)	19 (26)	27 (37)
9/16	3/8 - 16 UNC	20 (27)	31 (42)	44 (60)
9/16	3/8 - 24 UNF	23 (31)	35 (47)	49 (66)
5/8	7/16 - 14 UNC	32 (43)	49 (66)	70 (95)
5/8	7/16 - 20 UNF	36 (49)	55 (75)	78 (106)
3/4	1/2 - 13 UNC	49 (66)	76 (103)	106 (144)
3/4	1/2 - 20 UNF	55 (75)	85 (115)	120 (163)
7/8	9/16 - 12 UNC	70 (95)	109 (148)	153 (207)
7/8	9/16 - 18 UNF	79 (107)	122 (165)	172 (233)
15/16	5/8 - 11 UNC	97 (131)	150 (203)	212 (287)
15/16	5/8 - 18 UNF	110 (149)	170 (230)	240 (325)
1-1/8	3/4 - 10 UNC	144 (195)	266 (360)	376 (509)
1-1/8	3/4 - 16 UNF	192 (260)	297 (402)	420 (569)
1-5/16	7/8 - 9 UNC	166 (225)	430 (583)	606 (821)
1-5/16	7/8 - 14 UNF	184 (249)	474 (642)	668 (905)
1-1/2	1 - 8 UNC	250 (339)	644 (873)	909 (1232)
1-1/2	1 - 12 UNF	274 (371)	705 (955)	995 (1348)
1-1/2	1 - 14 UNF	280 (379)	721 (977)	1019 (1381)
1-11/16	1-1/8 - 7 UNC	354 (480)	795 (1077)	1288(1745)
1-11/16	1-1/8 - 12 UNF	397 (538)	890 (1206)	1444 (1957)
1-7/8	1-1/4 - 7 UNC	500 (678)	1120 (1518)	1817 (2462)
1-7/8	1-1/4 - 12 UNF	553 (749)	1241 (1682)	2013 (2728)
2-1/16	1-3/8 - 6 UNC	655 (887)	1470 (1992)	2382 (3228)
2-1/16	1-3/8 - 12 UNF	746 (1011)	1672 (2266)	2712 (3675)
2-1/4	1-1/2 - 6 UNC	870 (1179)	1950 (2642)	3161 (4283)
2-1/4	1-1/2 - 12 UNF	979 (1327)	2194 (2973)	3557 (4820)

### METRIC

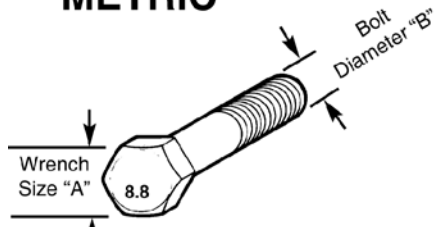

Numbers appearing on bolt heads indicate ASTM class.

Proper torque for metric fasteners used on Bush Hog equipment.  
Recommended torque in foot pounds (newton Meters).\*

WRENCH SIZE (mm) "A"	BOLT DIA. (mm) "B"	ASTM 4.6	ASTM 8.8	ASTM 9.8	ASTM 10.9
8	5	1.8 (2.4)		5.1 (6.9)	6.5 (8.8)
10	6	3 (4)		8.7 (12)	11.1 (15)
13	8	7.3 (10)		21.1 (29)	27 (37)
16	10	14.5 (20)		42 (57)	53 (72)
18	12	25 (34)	74 (100)	73 (99)	93 (126)
21	14	40 (54)	118 (160)	116 (157)	148 (201)
24	16	62 (84)	167 (226)	181 (245)	230 (312)
30	20	122 (165)	325 (440)		449 (608)
33	22		443 (600)		611 (828)
36	24	211 (286)	563 (763)		778 (1054)
41	27		821 (1112)		1138 (1542)
46	30	418 (566)	1119 (1516)		1547 (2096)

\*Use 75% of the specified torque value for plated fasteners. Use 85% of the specified torque values for lubricated fasteners.

TECHNICAL

# TECHNICAL DATA

## SERVICE and MAINTENANCE RECORDS

**Service or Maintenance  
Performed**

**Date**

**Meter  
Hours**

Service or Maintenance Performed	Date	Meter Hours

**TECHNICAL**

# TECHNICAL DATA

## NOTES

TECHNICAL









***BUSH HOG***<sup>®</sup>

Printed in U.S.A.

**HDZ-4 SERIES  
ZERO TURN MOWER**

**P/N 50081560**