



BUSH HOG®

PULL DISC HARROW

Models DHP8, DHP10, DHP12

Published 08/22

Part No.50072116

OPERATOR'S MANUAL



This Operator's Manual is an integral part of the safe operation of this machine and must be maintained with the unit at all times. **READ, UNDERSTAND,** and **FOLLOW** the Safety and Operation Instructions contained in this manual before operating the equipment. C01-Cover str

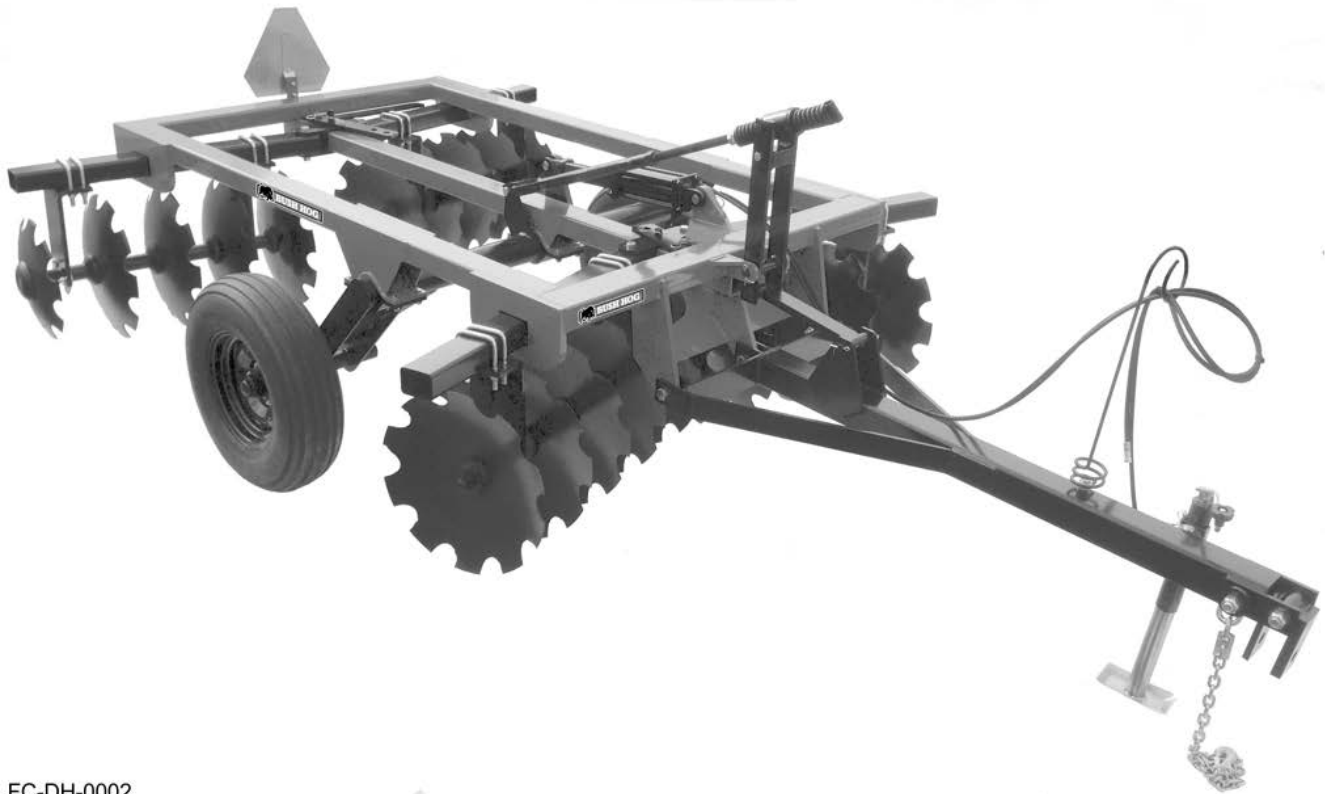

FC-DH-0002

BUSH HOG®

2501 Griffin Ave.
Selma, AL 36703
334-874-2700
www.bushhog.com

Bush Hog Web Page



www.alqr.com/bwe

¡ATENCIÓN!
LEA EL INSTRUCTIVO



Si No Lee Ingles, Pida
Ayuda a Alguien
Que Se Lo Lea Para Que le
Traduzca Las
Medidas de Seguridad





**A™ MEMBER OF THE
ALAMO GROUP**
ALWAYS ON THE CUTTING EDGE®

©2022 Alamo Group Inc.

To the Owner/Operator/Dealer

All implements with moving parts are potentially hazardous. There is no substitute for a cautious, safe-minded operator who recognizes the potential hazards and follows reasonable safety practices. The manufacturer has designed this implement to be used with all its safety equipment properly attached to minimize the chance of accidents.

BEFORE YOU START! Read the safety messages on the implement and shown in your manual. Observe the rules of safety and common sense!

 DANGER	
<p>TO AVOID SERIOUS INJURY OR DEATH:</p> <ul style="list-style-type: none">● READ AND UNDERSTAND the provided Operator's Manuals, safety signs and information decals for tractor and implement before operating equipment.● CONTACT DEALER immediately if you do not have manuals.● CONTACT DEALER to explain any instructions not fully understood.● KNOW HOW to stop tractor and equipment quickly for an emergency.● ALWAYS WEAR safety glasses.● WEAR hard hat, safety shoes and gloves for protection when operating equipment.	   
D604_3	

WARRANTY INFORMATION:

Read and understand the complete Warranty Statement found in this Manual. Fill out the Warranty Registration Form in full and return it to within 30 Days. Make certain the Serial Number of the Machine is recorded on the Warranty Card and on the Warranty Form that you retain.

Table of Contents

SAFETY SECTION	1 - 1
GENERAL SAFETY INSTRUCTIONS AND PRACTICES.....	1 - 2
OPERATOR SAFETY INSTRUCTIONS AND PRACTICES.....	1 - 3
EQUIPMENT OPERATION SAFETY INSTRUCTIONS AND PRACTICES	1 - 5
CONNECTING AND DISCONNECTING SAFETY INSTRUCTIONS AND PRACTICES.....	1 - 7
MAINTENANCE SAFETY INSTRUCTIONS AND PRACTICES.....	1 - 7
TRANSPORTING SAFETY INSTRUCTIONS AND PRACTICES	1 - 9
PARTS INFORMATION	1 - 11
CONCLUDING SAFETY INSTRUCTIONS AND PRACTICES.....	1 - 11
DECAL LOCATION	1 - 12
DECAL DESCRIPTION	1 - 14
FEDERAL LAWS AND REGULATIONS	1 - 15
INTRODUCTION SECTION.....	2 - 1
FEATURES.....	2 - 4
BEFORE OPERATING THIS MACHINE:	2 - 5
BUSH HOG LIMITED WARRANTY	2 - 6
ASSEMBLY SECTION.....	3 - 1
DEALER SET-UP INSTRUCTIONS	3 - 2
AXLE ASSEMBLY	3 - 2
SPINDLE/HUB/WHEEL ASSEMBLY.....	3 - 2
THREADED ROD ASSEMBLY.....	3 - 3
HITCH ASSEMBLY.....	3 - 3
HYDRAULIC CYLINDER ASSEMBLY.....	3 - 4
GANG ARM ASSEMBLY	3 - 5
DISC GANG ASSEMBLY	3 - 6
Disc Gang Positioning	3 - 7
OPTIONAL SCRAPER KITS ASSEMBLY	3 - 7
OPTIONAL CENTER SWEEP ASSEMBLY.....	3 - 8
PARKING BRAKE	3 - 9
SLOW MOVING VEHICLE SIGN.....	3 - 9
OPERATION SECTION	4 - 1
STANDARD EQUIPMENT AND SPECIFICATIONS	4 - 3
OPERATOR REQUIREMENTS	4 - 4
TRACTOR REQUIREMENTS	4 - 5
ROPS and Seat Belt.....	4 - 5
Tractor Safety Devices	4 - 5
Tractor Horsepower.....	4 - 5
Front End Weight.....	4 - 5

Table of Contents

GETTING ON AND OFF THE TRACTOR	4 - 6
Boarding the Tractor	4 - 6
Dismounting the Tractor	4 - 6
STARTING THE TRACTOR	4 - 7
CONNECTING THE IMPLEMENT TO THE TRACTOR	4 - 8
Connecting the Disc Harrow	4 - 8
Slow Moving Vehicle Sign	4 - 9
Bleeding Hydraulic Lines	4 - 9
PRE-FIELD ADJUSTMENTS	4 - 10
Side to Side Leveling	4 - 10
Front or Rear Leveling	4 - 10
Disc Gang Adjustment.....	4 - 10
IN-FIELD ADJUSTMENTS	4 - 11
Hydraulic Cylinder Depth Adjustment.....	4 - 12
Disc Gang Angle.....	4 - 12
Disc Leveling Front to Rear	4 - 12
Disc Blade Replacement	4 - 12
PRE-OPERATION INSPECTION AND SERVICE	4 - 13
Tractor Pre-Operation Inspection/Service	4 - 13
Implement Pre-Operation Inspection/Service	4 - 14
TRACTOR PRE-OPERATION INSPECTION	4 - 15
DISC HARROW PRE-OPERATION INSPECTION	4 - 17
DRIVING THE TRACTOR AND IMPLEMENT	4 - 18
Starting the Tractor	4 - 19
Brake and Differential Lock Setting	4 - 19
Driving the Tractor and Implement	4 - 20
OPERATING THE TRACTOR AND IMPLEMENT	4 - 20
Field Operating Instructions.....	4 - 20
DISCONNECTING THE CULTIVATOR FROM THE TRACTOR.....	4 - 21
IMPLEMENT STORAGE	4 - 22
TRANSPORTING THE TRACTOR AND IMPLEMENT	4 - 22
Transporting on Public Roadways.....	4 - 22
Hauling the Tractor and Implement	4 - 24
TROUBLESHOOTING GUIDE	4 - 26
MAINTENANCE SECTION	5 - 1
LUBRICATION	5 - 2
PROPER TORQUE FOR FASTENERS	5 - 2

SAFETY SECTION

Safety Section 1-1

SAFETY

GENERAL SAFETY INSTRUCTIONS AND PRACTICES

A careful operator is the best operator. Safety is of primary importance to the manufacturer and should be to the owner/operator. Most accidents can be avoided by being aware of your equipment, your surroundings, and observing certain precautions. The first section of this manual includes a list of Safety Messages that, if followed, will help protect the operator and bystanders from injury or death. Read and understand these Safety Messages before assembling, operating or servicing this Implement. This equipment should only be operated by those persons who have read the manual, who are responsible and trained, and who know how to do so responsibly.



The Safety Alert Symbol combined with a Signal Word, as seen below, is used throughout this manual and on decals which are attached to the equipment. The Safety Alert Symbol means: "ATTENTION! BECOME ALERT! YOUR SAFETY IS INVOLVED!" The Symbol and Signal Word are intended to warn the owner/operator of impending hazards and the degree of possible injury faced when operating this equipment.

Practice all usual and customary safe working precautions and above all--remember safety is up to YOU. Only YOU can prevent serious injury or death from unsafe practices.



Indicates an imminently hazardous situation that, if not avoided, WILL result in DEATH OR VERY SERIOUS INJURY.



Indicates an imminently hazardous situation that, if not avoided, COULD result in DEATH OR SERIOUS INJURY.



Indicates an imminently hazardous situation that, if not avoided, MAY result in MINOR INJURY.

Important

Identifies special instructions or procedures that, if not strictly observed, could result in damage to, or destruction of the machine, attachments or the environment.

NOTE: *Identifies points of particular interest for more efficient and convenient operation or repair.* (SG-1) str

READ, UNDERSTAND, and FOLLOW the following Safety Messages. Death or serious injury may occur unless care is taken to follow the warnings and instructions stated in the Safety Messages. Always use good common sense to avoid hazards. (SG-2) str



Si no lee ingles, pida ayuda a alguien que si lo lea para que le traduzca las medidas de seguridad. (SG-3) str

¡ LEA EL INSTRUCTIVO!



There are obvious and hidden potential hazards in the operation of this Implement as in all power-driven or pulled equipment. REMEMBER! This machine is often operated in rough terrain conditions that include grass, weeds, gullies, holes, slopes, hidden obstructions and the like. Serious injury or even death may occur unless care is taken to assure the safety of the operator and bystanders in the area. Do not operate this machine with anyone in the immediate area. Stop operating if anyone comes within 25 feet of the equipment. (STL-4) str

SAFETY

OPERATOR SAFETY INSTRUCTIONS AND PRACTICES

⚠ DANGER

Never operate the Tractor or Implement until you have read and completely understand this Manual, the Tractor Operator's Manual, and each of the Safety Messages found in the Manual or on the Tractor and Implement. Learn how to stop the tractor engine suddenly in an emergency. Never allow inexperienced or untrained personnel to operate the Tractor or Implement without supervision. Make sure the operator has fully read and understood the manuals prior to operation.

(SG-4)str



⚠ WARNING

The operator and all support personnel should wear hard hats, safety shoes, safety glasses, and proper hearing protection at all times for protection from injury including injury from items that may be thrown by the equipment. (SG-16)str

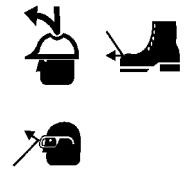

⚠ CAUTION

PROLONGED EXPOSURE TO LOUD NOISE MAY CAUSE PERMANENT HEARING LOSS! Tractors with or without an Implement attached can often be noisy enough to cause permanent hearing loss. We recommend that you always wear hearing protection if the noise in the Operator's position exceeds 80db. Noise over 85db over an extended period of time will cause severe hearing loss. Noise over 90db adjacent to the Operator over an extended period of time will cause permanent or total hearing loss. **NOTE:** *Hearing loss from loud noise [from tractors, chain saws, radios, and other such sources close to the ear] is cumulative over a lifetime without hope of natural recovery.* (SG-17)str



⚠ WARNING

Always read carefully and comply fully with the manufacturer's instructions when handling oil, solvents, cleansers, and any other chemical agent. (SG-22)str



⚠ DANGER

KEEP AWAY FROM ROTATING ELEMENTS to prevent entanglement and possible death or serious injury. (SG-24)str



⚠ DANGER

Never allow children to play on or around Tractor or Implement. Children can slip or fall off the Equipment and be killed or injured. Inadvertent contact with controls can cause the Implement to shift or fall crushing themselves or others. (SG-25)str

SAFETY

SAFETY

⚠ DANGER

DO NOT use drugs or alcohol immediately before or while operating the Tractor and Implement. Drugs and alcohol will affect an operator's alertness and coordination and therefore affect the operator's ability to operate the equipment safely. Before operating the Tractor or Implement, an operator on prescription or over-the-counter medication must consult a medical professional regarding any side effects of the medication that would hinder their ability to operate the Equipment safely. NEVER knowingly allow anyone to operate this equipment when their alertness or coordination is impaired. Serious injury or death to the operator or others could result if the operator is under the influence of drugs or alcohol. (SG-27) str

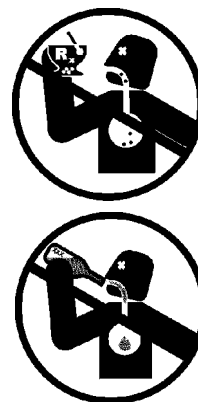

⚠ WARNING

Prolonged operation may cause operator boredom and fatigue affecting safe operation. Take scheduled work breaks to help prevent these potentially impaired operating conditions. Never operate the Implement and Tractor in a fatigued or bored mental state which impairs proper and safe operation. (SG-32) str

⚠ WARNING

Use extreme caution when getting onto the Implement to perform repairs, maintenance and when removing accumulated material. Only stand on solid flat surfaces to ensure good footing. Use a ladder or raised stand to access high spots which cannot be reached from ground level. Slipping and falling can cause serious injury or death. (SG-33) str

⚠ WARNING

Avoid contact with hot surfaces including hydraulic oil tanks, pumps, motors, valves and hose connections. Relieve hydraulic pressure before performing maintenance or repairs. Use gloves and eye protection when servicing hot components. Contact with a hot surface or fluid can cause serious injury from burns or scalding. (SG-34str)

⚠ DANGER

DO NOT operate this Implement on a Tractor that is not properly maintained. Should a mechanical or Tractor control failure occur while operating, immediately shut down the Tractor and perform repairs before resuming operation. Serious injury and possible death could occur from not maintaining this Implement and Tractor in good operating condition. (SG-36) str

⚠ WARNING

Avoid contact with hot surfaces of the engine or muffler. Use gloves and eye protection when servicing hot components. Contact with a hot surface or fluid can cause serious injury from burns or scalding. (SG-38) str

SAFETY

⚠️ WARNING

Repeated or substantial breathing of hazardous dusts, including crystalline silica, could cause fatal or serious respiratory disease including silicosis. Concrete, masonry, many types of rock, and various other materials contain silica sand. California lists respirable crystalline silica as a substance known to cause cancer. Operation of this equipment under certain conditions may generate airborne dust particles that could contain crystalline silica. In those conditions, personal protective equipment including an appropriate respirator must be used. If excessive dust is generated, a dust collection or suppression system should also be used during operation. (SG-41) str

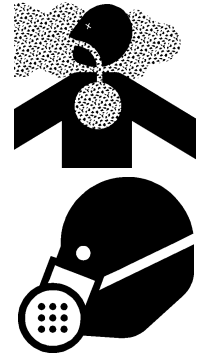

⚠️ WARNING

Be sure you have adequate knowledge of the property you will be working on. Take time to make yourself aware of any area underwater or underground lines or cables. Contact with buried lines or cable could result in serious injury or death. (STL-1) str

⚠️ WARNING

In wet conditions where there is a likelihood of material collecting on the Implement, make certain that this material is removed before traveling on public roadways. (STL-7) str

⚠️ WARNING

Never crawl under a raised Implement supported solely by the Tractor 3-Point hitch. Release of the control lever or mechanical failure will result in the Implement falling and possible injury or death. Always securely block up the Implement before crawling underneath to perform repairs and service. (S3PT-19) str

EQUIPMENT OPERATION SAFETY INSTRUCTIONS AND PRACTICES

⚠️ WARNING

Operate this Implement only in conditions where you have clear visibility in daylight or with adequate artificial lighting. Never operate in darkness or foggy conditions where you cannot clearly see at least 100 yards in front and to the sides of the tractor and implement. Make sure that you can clearly see and identify passersby, steep slopes, ditches, drop-offs, overhead obstructions, power lines, debris and foreign objects. If you are unable to clearly see these types of items discontinue operating this equipment. (S3PT-21) str

⚠️ WARNING

Operate this Equipment only with a Tractor equipped with an approved roll-over-protective system (ROPS). Always wear seat belts. Death or serious injury could result from falling off the tractor, particularly during a turnover when the operator could be pinned under the ROPS. (SG-7) str



SAFETY

SAFETY



BEFORE leaving the tractor seat lower the implement, set the parking brake and/or set the tractor transmission in parking gear, disengage the PTO, stop the engine, remove the key, and wait for all moving parts to stop. Place the tractor shift lever into a low range or parking gear to prevent the tractor from rolling. Never dismount a Tractor that is moving or while the engine is running. Operate the Tractor controls from the tractor seat only.

(SG-9)str

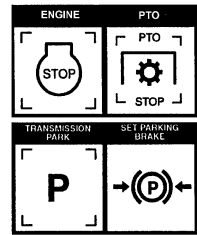

Never allow children or other persons to ride on the Tractor or Implement. Falling off can result in death or serious injury. (SG-10)str



Never allow children to operate, ride on, or come close to the Tractor or Implement. Usually, 16-17 year-old children who are mature and responsible can operate the implement with adult supervision, if they have read and understand the Operator's Manuals, been trained in proper operation of the tractor and Implement, and are physically large enough to reach and operate the controls easily. (SG-11) str



Do not mount or dismount the Tractor while the tractor is moving. Mount the Tractor only when the Tractor and all moving parts are completely stopped. Dismounting a moving power unit can result in a crushing hazard that can cause death or serious injury. (SG-12) str



Start tractor only when properly seated in the Tractor seat. Starting a tractor in gear can result in death or serious injury. Read the Tractor operators manual for proper starting instructions. (SG-13) str



Do not operate this Equipment with hydraulic oil or fuel leaking. Oil and fuel are explosive and their presence could present a hazard. Do not check for leaks with your hand! High-pressure oil streams from breaks in the line could penetrate the skin and cause tissue damage including gangrene. To check for a hose leak, SHUT the unit ENGINE OFF and remove all hydraulic pressure. Wear oil impenetrable gloves, safety glasses and use cardboard to check for evidence of oil leaks. If you suspect a leak, REMOVE the HOSE and have it tested at a Dealer. If oil does penetrate the skin, have the injury treated immediately by a physician knowledgeable and skilled in this procedure. (SG-15) str



Never run the Tractor engine in a closed building or without adequate ventilation. The exhaust fumes can be hazardous to your health. (SG-23) str

SAFETY



Operate the Tractor and/or Implement controls only while properly seated in the Tractor seat with the seat belt securely fastened around you. Inadvertent movement of the Tractor or Implement may cause death or serious injury. (SG-29)str



In case of mechanical difficulty during operation, place the transmission in the park position, set the parking brake, shut down all power, including the PTO and the engine and remove the key. Wait until all rotating motion has stopped before dismounting. (SG-39) str



Do Not operate this equipment in areas where insects such as bees, may attack you and/or cause you to lose control of the equipment. If you must enter in such areas, use a tractor with an enclosed Cab and close the windows to prevent insects from entering. If a tractor cab is not available, wear suitable clothing including head, face, and hand protection to shield you from the insects. Attacking insects can cause you to lose control of the tractor, which can result in serious injury or death to you or bystanders. Never dismount a moving tractor. (SG-40) str



Many varied objects, such as wire, cable, rope, or chains, can become entangled in the rotating parts of the Implement. These objects could then swing outside the housing at great velocity. Such a situation is extremely hazardous and could result in serious injury or even death. Inspect the area for such objects before working in the area. Remove any such objects from the site. Never allow the implement to contact such objects. (STL-6) str

SAFETY

CONNECTING AND DISCONNECTING SAFETY INSTRUCTIONS AND PRACTICES



Never unhitch without using the Tongue Jack. The Tongue is very heavy. Attempting to lift the Tongue without using the Tongue Jack could cause strains or other injury. Allowing the tongue to fall suddenly and unexpectedly could result in crushing injury. Use the Tongue Jack for lifting the Implement only. Overloading the Tongue Jack can cause failure with possible serious bodily injury or even death. (STI-04) str

MAINTENANCE SAFETY INSTRUCTIONS AND PRACTICES



Always maintain the safety signs in good readable condition. If the safety signs are missing, damaged, or unreadable, obtain and install replacement safety signs immediately. (SG-5)str



Do not modify or alter this Implement. Do not permit anyone to modify or alter this Implement, any of its components or any Implement function. (SG-8)str



Never work under the Implement, the framework, or any lifted component unless the Implement is securely supported or blocked up to prevent sudden or inadvertent falling which could cause death or serious injury. (SG-14)str



Never attempt to lubricate, adjust, or remove material from the Implement while it is in motion or while tractor engine is running. (SG-20)str

SAFETY

⚠ WARNING Cancer and Reproductive Harm www.P65Warnings.ca.gov

⚠ WARNING

Periodically inspect all moving parts for wear and replace when necessary with authorized service parts. Look for loose fasteners, worn or broken parts, and leaky or loose fittings. Make sure all pins have cotter pins and washers. Serious injury may occur from not maintaining this machine in good working order. (SG-21) str

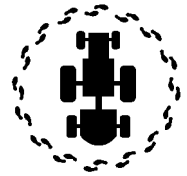

⚠ WARNING

Perform service, repairs and lubrication according to the maintenance section. Ensure the unit is properly lubricated as specified in the lubrication schedule and all bolts and nuts are properly torqued. Failure to properly service, repair and maintain this Implement in good operating condition could cause component failure and possible serious injury or even death. (SG-35str)

⚠ WARNING

Use caution and wear protective gloves when handling sharp objects such as blades, knives, and other cutting edges. Be alert to worn component surfaces which have sharp edges. Sharp surfaces can inflict severe laceration injuries if proper hand protection is not worn. (SG-37) str

⚠ WARNING

Ensure any remote starting system is inoperative before servicing or cleaning the machine. Inadvertent engine start up could result in entanglement or runover causing serious injuries or death. (SSB-17) str

⚠ WARNING

Use extreme care when climbing onto the Equipment to perform repairs, maintenance, and cleaning. Use proper stands and ladders to access areas that cannot be reached from ground level. Slipping and falling off the Equipment can cause serious injury or death. (SSB-25) str

⚠ WARNING

Exercise care when handling the discs. Disc blades are SHARP and HEAVY. Wear gloves at all time to protect your hands. (STL-10) str

⚠ WARNING

Do not use your hands or feet to clean the disc gangs. The discs are sharp and serious injures could result from inadvertent contact with the discs. Never attempt to stand on the discs, tires, or frame members of the implement. (STL-11) str

SAFETY

TRANSPORTING SAFETY INSTRUCTIONS AND PRACTICES



Be particularly careful when transporting the Implement using the tractor. Turn curves or go up or down hills only at a low speed and at a gradual steering angle. Make certain that at least 20% of the tractor's weight is on the front wheels to maintain safe steering. Slow down on rough or uneven surfaces. (STI-01) str



Only tow the Implement behind a properly sized and equipped Tractor which exceeds the weight of the Implement by at least 20%. DO NOT tow the Implement behind a truck or other type of vehicle. Never tow the Implement and another Implement connected in tandem. Never tow the Implement at speeds over 20 MPH. (STI-06)str



Your driving vision may be reduced or impaired by the tractor, cab, or implement. Before driving on public roadways identify any limited vision areas, and make adjustments to your operating position, mirrors, and the implement transport position so that you can clearly see the area where you will be traveling, and any traffic that may approach you. Failure to maintain adequate vision of the public roadway and traffic can result in serious injury or even death. (STI-10)



Lock the disc gangs in the raised position before transporting the Implement. Serious Implement and/or road damage could result from unintentional dropping of the discs gangs. Be sure to pin the tractor drawbar rigid in the center position and properly attach the Implement safety tow chain. (STL-9) str



Make certain that the "Slow Moving Vehicle" (SMV) sign is installed in such a way as to be clearly visible and legible. When transporting the Equipment use the Tractor flashing warning lights and follow all local traffic regulations. (SG-6)str

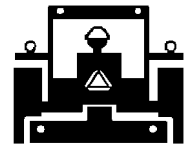

SAFETY

SAFETY

WARNING

Transport only at speeds where you can maintain control of the equipment. Serious accidents and injuries can result from operating this equipment at high speeds. Understand the Tractor and Implement and how it handles before transporting on streets and highways. Make sure the Tractor steering and brakes are in good condition and operate properly.



Before transporting the Tractor and Implement, determine the proper transport speeds for you and the equipment. Make sure you abide by the following rules:

Test the tractor at a slow speed and increase the speed slowly. Apply the Brakes smoothly to determine the stopping characteristics of the Tractor and Implement. As you increase the speed of the Tractor the stopping distance increases. Determine the maximum transport speed not to exceed 20 mph (30 kph) for transporting this equipment.

Test the equipment at a slow speed in turns. Increase the speed through the turn only after you determine that the equipment can be operated at a higher speed. Use extreme care and reduce your speed when turning sharply to prevent the tractor and implement from turning over. Determine the maximum turning speed for you and this equipment before operating on roads or uneven ground.

Only transport the Tractor and Implement at the speeds which allow you to properly control the equipment.

Be aware of the operating conditions. Do not operate the Tractor with weak or faulty brakes or worn tires. When operating down a hill or on wet or rain slick roads, the braking distance increases: use extreme care and reduce your speed. When operating in traffic always use the Tractor's flashing warning lights and reduce your speed. Be aware of traffic around you and watch out for the other guy. (SG-19)str



SAFETY

SAFETY

SAFETY

PARTS INFORMATION

Bush Hog products are designed utilizing specifically matched system components to ensure optimum equipment performance. These parts are made and tested to Bush Hog specifications. Non-genuine "will fit" parts do not consistently meet these specifications. The use of "will fit" parts may reduce equipment performance, void warranties, and present a safety hazard. Use genuine Bush Hog parts for economy and safety. (SPBH-2)str

SEE YOUR BUSH HOG DEALER

Operator's & Parts Manuals



www.algqr.com/bpm

CONCLUDING SAFETY INSTRUCTIONS AND PRACTICES

In addition to the design and configuration of this Implement, including Safety Signs and Safety Equipment, hazard control and accident prevention are dependent upon the awareness, concern, prudence, and proper training of personnel involved in the operation, transport, maintenance, and storage of the machine. Refer also to Safety Messages and operation instruction in each of the appropriate sections of the Tractor and Equipment Manuals. Pay close attention to the Safety Signs affixed to the Tractor and Equipment. (SG-18)str

SAFETY

DECAL LOCATION

Note: BUSH HOG supplies safety decals on this product to promote safe operation. Damage to the decals may occur while in shipping, use or reconditioning. BUSH HOG cares about the safety of its customers, operators, and bystanders, and will replace the safety decals on this product in the field, free of charge (Some shipping and handling charges may apply). Contact BUSH HOG dealer to order replacement decals.

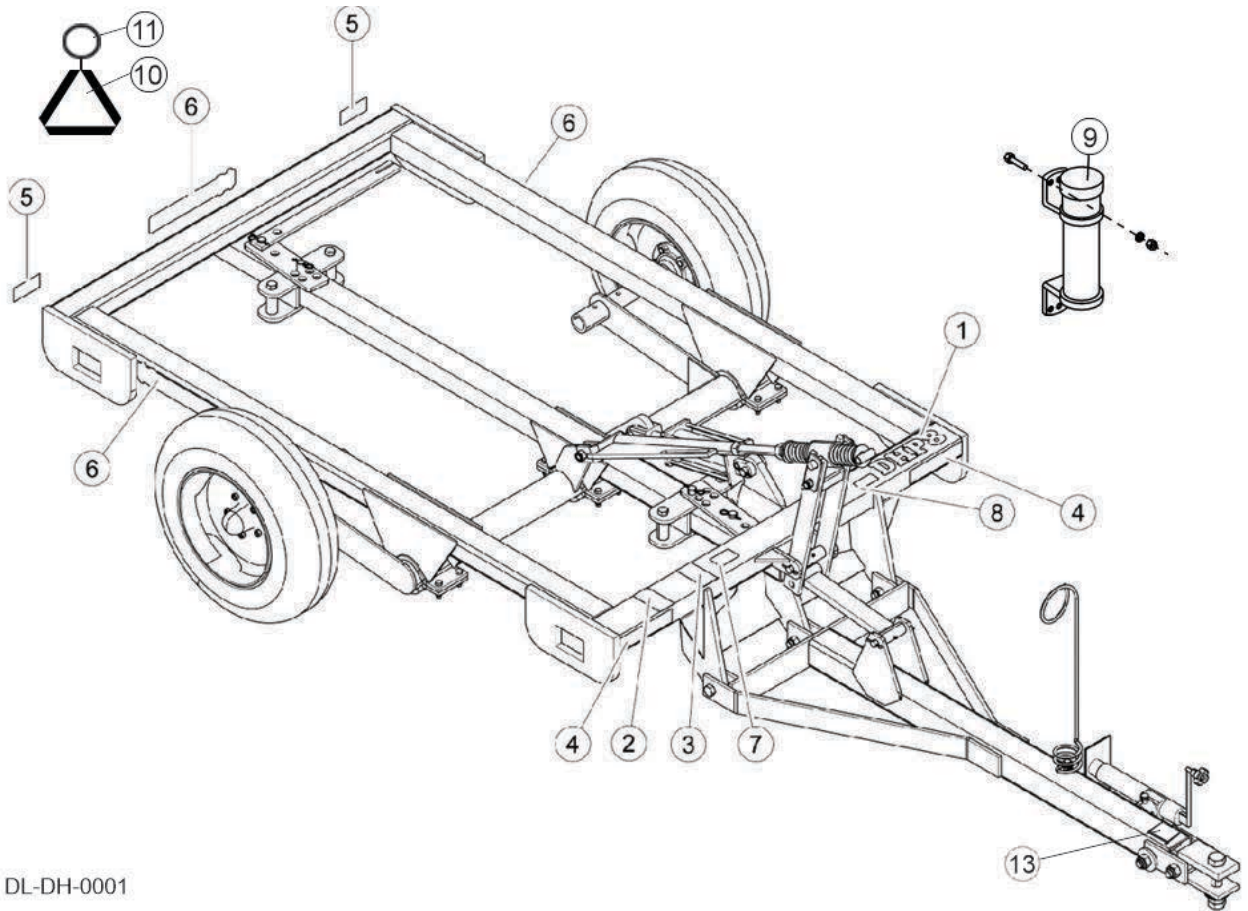

DL-DH-0001

SAFETY

SAFETY

ITEM	PART NO.	QTY	TYPE	DESCRIPTION
1.	50072042	1	NAME	Model Decal DHP8
	50072040	1	NAME	Model Decal DHP10
	50072053	1	NAME	Model Decal DHP12
2.	50057097	1	CAUTION	Multi-Hazard
3.	90960BH	1	WARNING	Multi-Hazard
4.	50031212	2	REFLECT	Amber Reflector
5.	50031213	2	REFLECT	Red Reflector
6.	50065309	3	LOGO	Bush Hog
7.	00725746	1	PELIGRO	Spanish Translation
8.	NFS	1	SERIAL PLT	Serial Number Plate
9.	00789085C	1	---	Canister (Operator's Manual inside)
10.	94359	1	REFLECT	SMV Sign
11.	D1064	1	IMPORTANT	20 MPH Speed
12.	D960	1	WARNING	Proposition 65
13.	D1085	1	---	Park on Level Ground, Max 10% Ground Speed

SAFETY

SAFETY

DECAL DESCRIPTION

! PELIGRO
LEA EL INSTRUCTIVO

Si No Lee Ingles, Pida Ayuda a Alguien Que Si Lo Lea Para Que le Traduzca las Medidas de Seguridad.

00725746

! WARNING
Cancer and Reproductive Harm
www.P65 Warnings.ca.gov

D960

! WARNING

TO AVOID SERIOUS INJURY OR DEATH:

1. DURING RAKE ADJUSTMENTS:

- *AVOID RAKE SWING DOWNHILL WHEN INDEX PINS ARE REMOVED; PLACE TRACTOR ON LEVEL GROUND.
- *KEEP FINGERS AWAY FROM ADJUSTING HOLES.
- *KEEP BODY, HANDS AND FEET CLEAR FROM ELEVATED RAKE AND MOVING PARTS.

2. DURING RAKE OPERATION:

- *AVOID HIGH SPEED OVER ROUGH TERRAIN OR SLOPES.

90960BH

! CAUTION

TO AVOID SERIOUS INJURY OR DEATH:

- READ OPERATORS MANUAL BEFORE OPERATING AND FOLLOW ALL PRECAUTIONS (CONTACT DEALER FOR MANUAL).
- IT IS RECOMMENDED OPERATOR USE ROLLOVER PROTECTIVE SYSTEM AND SEAT BELT EQUIPPED TRACTOR FOR ALL IMPLEMENT OPERATIONS.
- ADD TRACTOR FRONT END WEIGHTS REQUIRED FOR TRACTOR STABILITY.
- LOWER IMPLEMENT TO GROUND, STOP ENGINE, PLACE TRANSMISSION IN NEUTRAL OR PARK, SET PARKING BRAKE AND REMOVE KEY BEFORE DISMOUNTING TRACTOR OR ADJUSTING IMPLEMENT.
- ALLOW NO RIDERS.
- TRANSPORT BLADE IN FULL RAISED POSITION WITH TILT AND OFFSET ANGLES AT "ZERO" POSITION.

50057097

20
mile/h

NOTICE

Do not tow at speeds greater than 20 MPH (30 KM/H).
Ensure mass of towing vehicle is at least 2/3 times the mass of the towed machinery.
Be sure to park on level ground to a maximum of 10% ground slope.

D1085

SAFETY

SAFETY

FEDERAL LAWS AND REGULATIONS

This section is intended to explain in broad terms the concept and effect of federal laws and regulations concerning employer and employee equipment operators. This section is not intended as a legal interpretation of the law and should not be considered as such.

Employer-Employee Operator Regulations

U.S. Public Law 91-596 (The Williams-Steiger Occupational and Health Act of 1970) OSHA

This Act Seeks:

“...to assure so far as possible every working man and woman in the nation safe and healthful working conditions and to preserve our human resources...”

DUTIES

Sec. 5 (a) Each employer-

(1) shall furnish to each of his employees employment and a place of employment which are free from recognized hazards that are causing or are likely to cause death or serious physical harm to his employees;

(2) shall comply with occupational safety and health standards promulgated under this Act.

(b) Each employee shall comply with occupational safety and health standards and all rules, regulations and orders issued pursuant to this Act which are applicable to his own actions and conduct.

OSHA Training Requirements

Title 29, Code of Federal Regulations Part 1928.57(a)(6). www.osha.gov

Operator instructions. At the time of initial assignment and at least annually thereafter, the employer shall instruct every employee who operates an agricultural tractor and implements in the safe operating practices and servicing of equipment with which they are or will be involved, and of any other practices dictated by the work environment.

Keep all guards in place when the machine is in operation;

Permit no riders on equipment

Stop engine, disconnect the power source, and wait for all machine movement to stop before servicing, adjusting, cleaning or unclogging the equipment, except where the machine must be running to be properly serviced or maintained, in which case the employer shall instruct employees as to all steps and procedures which are necessary to safely service or maintain the equipment.

Make sure everyone is clear of machinery before starting the engine, engaging power, or operating the machine.

Employer Responsibilities:

To ensure employee safety during Tractor and Implement operation, it is the employer's responsibility to:

1. Train the employee in the proper and safe operation of the Tractor and Implement.
2. Require that the employee read and fully understand the Tractor and Implement Operator's Manual.
3. Permit only qualified and properly trained employees to operate the Tractor and Implement.
4. Maintain the Tractor and Implement in a safe operational condition and maintain all shields and guards on the equipment.
5. Ensure the Tractor is equipped with a functional ROPS and seat belt and require that the employee operator securely fasten the safety belt and operate with the ROPS in the raised position at all times.
6. Forbid the employee operator to carry additional riders on the Tractor or Implement.
7. Provide the required tools to maintain the Tractor and Implement in a good safe working condition and provide the necessary support devices to secure the equipment safely while performing repairs and service.
8. Require that the employee operator stop operation if bystanders or passersby come within 300 feet.

Child Labor Under 16 Years of Age

Some regulations specify that no one under the age of 16 may operate power machinery. It is your responsibility to know what these regulations are in your own area or situation. (Refer to U.S. Dept. of Labor, Employment Standard Administration, Wage & Home Division, Child Labor Bulletin #102.)

INTRODUCTION SECTION

Introduction Section 2-1

INTRODUCTION

INTRODUCTION

These Disc Harrows are designed with care and built with quality materials by skilled workers. Proper assembly, maintenance, and operating practices, as described in this manual, will help the owner/operator get years of satisfactory service from the machine.

The purpose of this manual is to familiarize, instruct, and train. The Assembly Section instructs the owner/operator in the correct assembly of the Implement using standard and optional equipment. The Parts Manual is designed to familiarize the owner/operator with replaceable parts on the Implement. This manual provides exploded assembly drawings of each implement component illustrating each piece and the corresponding part number.

Careful use and timely service save extensive repairs and costly downtime losses. The Operation and Maintenance Sections of the manual train the owner/operator how to work the Implement correctly and attend to appropriate maintenance. The Trouble Shooting Guide helps diagnose difficulties with implement and offers solution to the problems.

Safety is of primary importance to the owner/operator and to the manufacturer. The first section of this manual includes a list of Safety Messages, that, if followed, will help protect the operator and bystanders from injury or death. Many of the Safety Messages will be repeated throughout the manual. The owner/operator/dealer should know these Safety Messages before assembly and be aware of the hazards of operating this implement during assembly, use, and maintenance. The Safety Alert Symbol combined with a Signal Word, as seen below, is intended to warn the owner/operator of impending hazards and the degree of possible injury faced when operating this machine.



Indicates a hazardous situation that, if not avoided, WILL result in DEATH OR VERY SERIOUS INJURY.



Indicates a hazardous situation that, if not avoided, COULD result in DEATH OR SERIOUS INJURY.



Indicates a hazardous situation that, if not avoided, MAY result in MINOR OR MODERATE INJURY.

Important

Identifies special instructions or procedures that, if not strictly observed, could result in damage to, or destruction of the machine, attachments or the environment.

INTRODUCTION

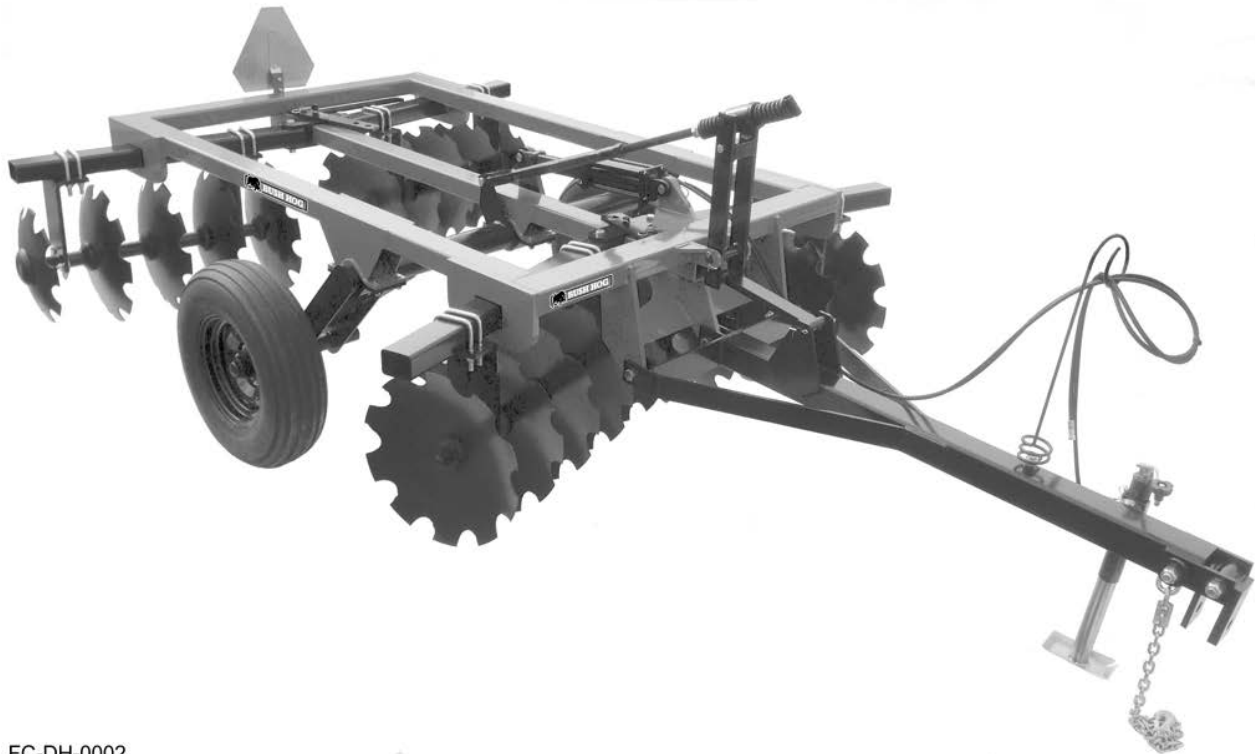

FC-DH-0002

INTRODUCTION

Bush Hog Disc Harrows are designed for garden preparation, game food plots, firebreaks or orchard-vineyard use. Be sure to remove any sizable tree limbs, rocks, or debris from this area. Do not attempt to disc wet or mucky soil and all areas should be well drained and capable of being walked on without having the soil stick to your shoes..

Discing action will commence as soon as you lower the disc from transport position, the unit touches the ground, and tractor horsepower, Never try to disc in reverse and when you reach the end of a pass, raise the unit up into transport before turning. Trying to turn sharply with the unit in the ground will cause extreme side loading on the discs and may cause damage. Making disc gang adjustments is relatively easy by raising the disc off of the ground, pulling the locking pin, making the required gang angle adjustment, and then reverse the process till your back in action. It is extremely important that the disc harrow operates level at all times. This will minimize the horsepower requirements and allow the best flow of soil and residue through the machine.

Ground conditions and the finish you require will determine how you position the angles of your front and rear disc gangs. Both of the front and rear disc gangs have the angle adjustment positions. The best ground finish will usually be achieved when the rear gang is set at a slightly lesser angle than the front gang. The more aggressive you set the angle of the gangs, the more aggressive the cutting action in the soil profile will be. The more aggressive the cutting action is, the more horsepower will be required to pull you unit. Achieving the desired effect may require a little experimentation in your given conditions. If the soil is building up on or sticking to our discs then the soil is too wet and discing operations should be discontinued until the ground is dry and more workable. Optional disc scrapers are recommended and will significantly improve overall performance in conditions where soil continually tends to buildup or stick to discs.

Literature Page



www.algqr.com/ble

INTRODUCTION

Once you have finished using your disc, travel to storage area, lower it out of transport position parking it on a level surface. Clean it, service it, and make sure it is ready for the next use by replacing any parts that may have become excessively worn or damaged during field operation.

FEATURES

- Square and rectangle tube steel frames and gang tubes
- Adjustable gang angles, front and rear
- Variable blade spacings available: You get the best of both worlds.
 - 9" front and rear gangs for tough-to-cut "New Ground"
 - 7-1/2" front and rear gangs for finer soil finishing
 - 9" front gangs - 7-1/2" rear gangs
- Notched disc blades for maximum cutting action
- 1-1/8" square, high carbon steel gang axles
- Available in tractor colors
- Optional disc scrapers
- Center Sweep Kit
- Dual Wheel Transport Kit

NOTE: All reference made in this manual to right, left, front, rear, top or bottom are as viewed facing the direction of forward travel with implement properly attached to tractor. Attention Owner/Operator

INTRODUCTION

BEFORE OPERATING THIS MACHINE:

1. Carefully read the Operator's Manual, completely understand the Safety Messages and instructions, and know how to operate correctly both the tractor and implement.
2. Fill out the Warranty Card in full. Be sure to answer all questions, including the Serial Number of the Mower. Mail within 30 days of delivery date of this implement.

NOTE: Warranties are honored only if completed "Owner Registration and Warranty" forms are received by Bush Hog within thirty days of delivery of the implement.

3. Record the Model and Serial Numbers on the Warranty page provided to with your Operator's and Part's manual package. Keep this as part of the permanent maintenance file for the implement.

⚠ WARNING

TO AVOID DEATH OR SERIOUS INJURY:

- ONLY use genuine Bush Hog replacement parts, which have been validated and tested to use on Bush Hog equipment by the manufacturer.
- The equipment manufacturer cannot verify the material or structural integrity of third-party supplied non-genuine replacement parts.
- Using non-genuine parts can result in the part failing, creating hazardous conditions for operator and bystanders.

Contact local dealer or Bush Hog about repair parts at:
2501 Griffin Ave., Selma, AL 36701
Customer Service: 800-363-6096.
Email: contactus@bushhog.com www.algqr.com/bpm



⚠ WARNING
Cancer and Reproductive Harm
www.P65Warnings.ca.gov

IMPORTANT

BE AWARE BE ALERT BE ALIVE	BE TRAINED Before Operating this Mower
---	---



To prevent serious injury to yourself and/or bystanders, be trained in Safe Mowing Practices. Alamo Group Companies as well as AEM and FEMA provide training material that is critical for your Safety and the Safety of others when operating this equipment. Make these Safety Procedures an important part of every workday. Read and understand the Operator's Manual. www.algqr.com/bve

Do not let untrained individuals operate this equipment. Contact your Dealer, AEM (www.aem.org), FEMA (314-878-2304, www.FarmEquip.org), or Alamo Group (www.Alamo-Group.com) for information on training material or courses that provide training in Safer Operating Practices for Mowers.

D559

INTRODUCTION

BUSH HOG LIMITED WARRANTY



Bush Hog warrants to the original purchaser of any new Bush Hog equipment, purchased from an authorized Bush Hog dealer, that the equipment be free from defects in material and workmanship for a period of one (1) year for non-commercial, state and municipalities' use and ninety (90) days for commercial use from date of retail sale. The obligation of Bush Hog to the purchaser under this warranty is limited to the repair or replacement of defective parts.

Replacement or repair parts installed in the equipment covered by this limited warranty are warranted for ninety (90) days from the date of purchase of such part or to the expiration of the applicable new equipment warranty period, whichever occurs later. Warranted parts shall be provided at no cost to the user at an authorized Bush Hog dealer during regular working hours. Bush Hog reserves the right to inspect any equipment or parts which are claimed to have been defective in material or workmanship.

DISCLAIMER OF IMPLIED WARRANTIES & CONSEQUENTIAL DAMAGES

Bush Hog's obligation under this limited warranty, to the extent allowed by law, is in lieu of all warranties, implied or expressed, **INCLUDING IMPLIED WARRANTIES OF MERCHANTABILITY AND FITNESS FOR A PARTICULAR PURPOSE** and any liability for incidental and consequential damages with respect to the sale or use of the items warranted. Such incidental and consequential damages shall include but not be limited to: transportation charges other than normal freight charges; cost of installation other than cost approved by Bush Hog; duty; taxes; charges for normal service or adjustment; loss of crops or any other loss of income; rental of substitute equipment, expenses due to loss, damage, detention or delay in the delivery of equipment or parts resulting from acts beyond the control of Bush Hog.

THIS LIMITED WARRANTY SHALL NOT APPLY:

1. To vendor items which carry their own warranties, such as engines, tires, and tubes.
2. If the unit has been subjected to misapplication, abuse, misuse, negligence, fire or other accident.
3. If parts not made or supplied by Bush Hog have been used in connection with the unit, if, in the sole judgment of Bush Hog such use affects its performance, stability or reliability.
4. If the unit has been altered or repaired outside of an authorized Bush Hog dealership in a manner which, in the sole judgment of Bush Hog, affects its performance, stability or reliability.
5. To normal maintenance service and normal replacement items such as gearbox lubricant, hydraulic fluid, worn blades, or to normal deterioration of such things as belts and exterior finish due to use or exposure.
6. To expendable or wear items such as teeth, chains, sprockets, belts, springs and any other items that in the company's sole judgment is a wear item.

NO EMPLOYEE OR REPRESENTATIVE OF BUSH HOG IS AUTHORIZED TO CHANGE THIS LIMITED WARRANTY IN ANY WAY OR GRANT ANY OTHER WARRANTY UNLESS SUCH CHANGE IS MADE IN WRITING AND SIGNED BY BUSH HOG'S SERVICE MANAGER, 2501 GRIFFIN AVE., SELMA, ALABAMA 36703.



Record the model number, serial number and date purchased. This information will be helpful to your dealer if parts or service are required.

MODEL NUMBER _____

SERIAL NUMBER _____

MAKE CERTAIN THE WARRANTY HAS BEEN FILED WITH BUSH HOG SELMA, ALABAMA

DATE OF RETAIL SALE _____



BUSH HOG®

ASSEMBLY SECTION

Assembly Section 3-1

ASSEMBLY

DEALER SET-UP INSTRUCTIONS

The Bush Hog DHP8, DHP10 and the DHP12 pull-type discs are perfectly matched for agricultural utility tractor having 45 to 80 drawbar horsepower. They have applications in seed bed preparation, soil pulverization, and tillage on smaller farms, ranches, construction sites, race tracks, rodeo grounds, nurseries, reclamation sites, and sod farms. Economy conscious customers will find them more than equal to just about any soil cultivation task you can throw at them. With notched or smooth 20" or 22" discs mounted on front and rear gangs that have easily adjustable angling, the DHP8, DHP10 and DHP12 readily adapt to a wide range of tillage conditions.



Always use personal protection devices such as eye and ear protectors during assembly.

AXLE ASSEMBLY

1. Unpack Disc Harrow from shipping crate.
2. Secure axle assembly (3) to frame with 3 axle clamps (1).
3. Fasten axle clamps with 1/2"x2" HHCS and 1/2" nylock nuts (2). **Asm-D-0004**

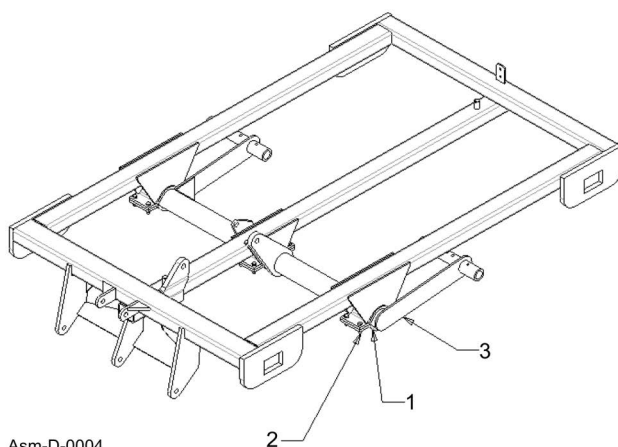

SPINDLE/HUB/WHEEL ASSEMBLY

1. Unpack Disc Harrow from shipping crate.
2. Support main frame with a suitable lifting device,
3. Verify fit-up of spindle/hub (2) to support tube (3) by assembling the two together without anti-seize lubricant.
4. Remove spindle from support tube and apply a thin coat of anti-seize lubricant.
5. Insert spindle (2) into support tube (3) and secure with two 1/2"-13x3-1/4" GR5 capscrews (5) and 1/2" locknuts (6). Tighten to the correct torque.
6. Mount wheel (1) to hub with five 1/2"-20lug nuts (4). Tighten lug nuts to the correct torque.
7. Repeat steps 2 - 6 for the opposite side. **Asm-D-0005**

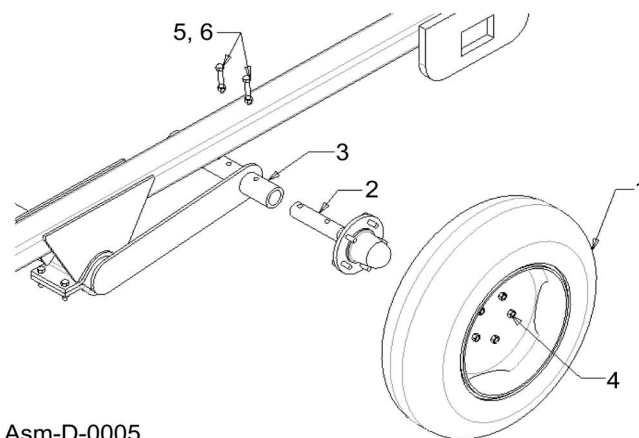

ASSEMBLY

THREADED ROD ASSEMBLY

1. Slide or thread large spring (1), spring cup assembly (3), small spring (4), 1-1/8" USS washer (5) and 1-1/8" hex nuts (6) onto the threaded rod (1) as shown.
2. Screw the threaded rod (1) into the tube weldment (7) about 9-1/2". This may be adjusted after the tongue, frame and pivot assembly have been assembled. **Asm-D-0006**

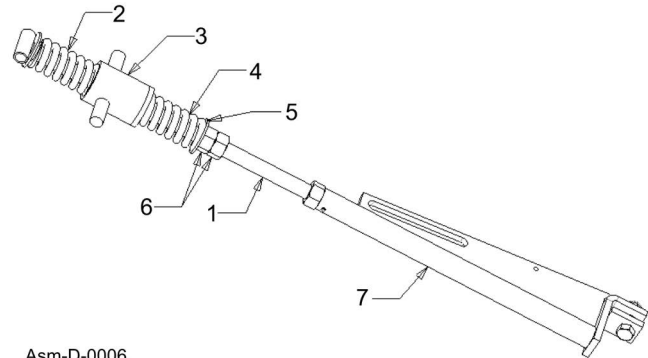

Asm-D-0006

HITCH ASSEMBLY

1. Attach tongue (1) to main frame (2) with three 7/8"-9 x 4" GR 5 capscrews (3) and 7/8" nylock nut (4). Loosely fasten nuts. **DO NOT TIGHTEN.**
2. If included, rotate optional parking jack (5) to the upright position and retain with pin (6). Extend jack to support hitch approximately 18" off the ground.
3. Attach midpoint of pivot weldment (8) to the mainframe (2) with one 7/8" x 7-1/2" pin (9) and two 1/4" x 2" cotter pins (10). Bend one or both legs of cotter pins to prevent them from falling out.
4. Attach pivot weldment (8) to tongue (1) with one 7/8" x 6" pin (11) and two 1/4" x 2" cotter pins (10). Bend one or both legs of cotter pin.
5. Attach threaded rod assembly (7) to axle lug (12) with one 3/4" - 10 x 2-1/2" GR 5 capscrew (13) and 3/4" nylock (14). Fasten nut. **DO NOT TIGHTEN.**
6. Secure the hose spring (15) with one 1/2" - 13 x 1" capscrew (16) and two 1/2" USS washer (17) to the welded nut on top of tongue frame (1) as shown. Tighten bolt to the correct torque.
7. Mount the five stroke control spacer (18) onto the spring adjuster (19) storage rack.
8. Attach cylinder transport lock (20) to spring adjuster gusset with 1/4" x 2" ire retaining pin (21).
9. Make sure the safety chain (22) is attached to the tongue using the 3/8" x 3" safety chain washer (23), 1" - 8 x 7-1/2" capscrew (24) and 1" nylock (25).
10. Secure the pull hitch assembly (26) to the tongue (1) with a 1" - 8 x 6-1/2" capscrew (27) and one 1" nylock (28).
11. A 1-1/4" - 7 x 6-1/2" (29) and four 1-1/4" SAE washers (30) are secured to the pull hitch by a 1-1/4" hex nut (31) and a 1-1/4" hex jam nut (32) for attaching to the drawbar.

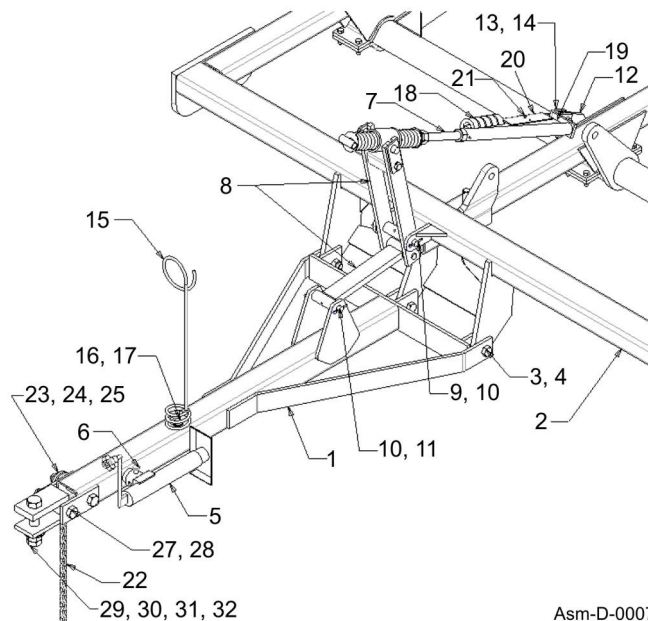

Asm-D-0007

ASSEMBLY

WARNING

Do not operate this Equipment with hydraulic oil or fuel leaking. Oil and fuel are explosive and their presence could present a hazard. Do not check for leaks with your hand! High-pressure oil streams from breaks in the line could penetrate the skin and cause tissue damage including gangrene. To check for a hose leak, SHUT the unit ENGINE OFF and remove all hydraulic pressure. Wear oil impenetrable gloves, safety glasses and use cardboard to check for evidence of oil leaks. If you suspect a leak, REMOVE the HOSE and have it tested at a Dealer. If oil does penetrate the skin, have the injury treated immediately by a physician knowledgeable and skilled in this procedure. (SG-15) str



ASSEMBLY

HYDRAULIC CYLINDER ASSEMBLY

Important

Attach cylinder base to the front main frame lug. Hydraulic fittings will be stressed if cylinder base is attached to the rear mainframe lug.

1. Position hydraulic cylinder (1) with ports on top as shown. Install two 90 degree elbows (2) into the cylinder ports with elbow fittings facing forward. Tighten elbows in cylinder as needed.
2. Screw 123" long hydraulic hoses (3) into the front and rear elbow at cylinder base end and tighten.
3. Purge hydraulic cylinder of air before continuing.
 - a. Place hydraulic cylinder near a hydraulic power source on the ground in an area where it can be extended and retracted freely.
 - b. Connect hydraulic hoses to a power source.
 - c. Fully extend and retract cylinder two or more cycles until cylinder rod moves in and out smoothly.
 - d. Follow instructions for "**Bleeding Hydraulic Lines**" if cylinder continue to move in uneven strokes.
4. Attach hydraulic cylinder base to the mainframe lug with 1" x 3-1/4" cylinder pin (4). Use .148" x 3" hair pin to secure cylinder pin (5). Make sure hydraulic ports are positioned on top and cylinder base positioned to the front as shown.
5. Route hydraulic hoses through pivot bracket (6) and spring hose loop (7).
6. Adjust fittings on cylinder as needed to prevent wear on outside of hose due to any frame contact.
7. Connect hydraulic hoses to a power source and extend cylinder until holes in the rod clevis align with axle lug hole.
8. Attach cylinder rod to axle frame with 1" x 3-1/4" clevis pin (4) and hair pin (5).
9. Fully extend hydraulic cylinder.
10. Remove transport lock (20) from storage bar (19) and pin to cylinder rod with wire retaining pin (21). Refer to Hitch Assembly drawing.
11. Retract cylinder until weight of Disc Harrow is supported by the transport lock.

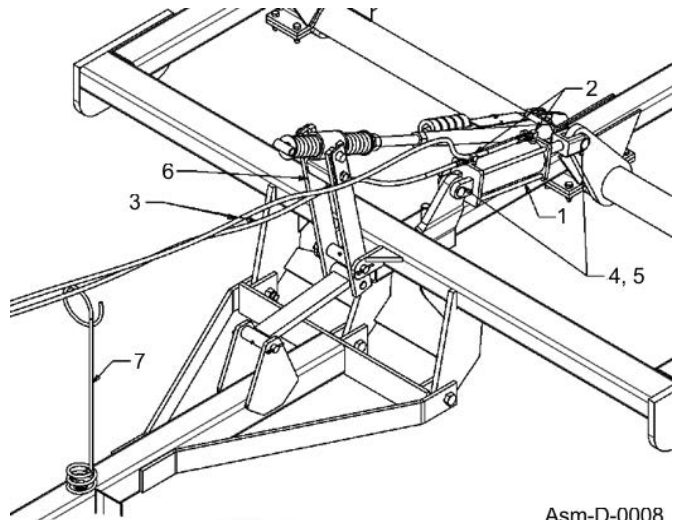

ASSEMBLY

GANG ARM ASSEMBLY

1. Insert gang tubes (1) through slots at rear of mainframe with pivot hole end in first with all decals facing up
 2. Connect the two arms together at the center with two spacers (2), one angle adjustment assembly (3), one angle adjustment plate (4), two 3/4"-10 x 5" GR5 hex head capscrews (5), and two 3/4" nylocks (6). Tighten locknuts to the correct torque.
 3. Insert 1/2" spacer (7) over rear pin located on the mainframe.
 4. Install end hole on angle adjustment bar (8) over rear frame pin and angle adjustment pin. The cutting angle is determined by what hole is used for the angle adjustment assembly.
 5. Secure stabilizer bar with hairpins (9).
 6. Apply a head of silicone on the inside lip of the swing tube outer ends.
- NOTE:** Bolt (7) must be inserted into the left side of slide bracket (5) before positioning the bracket under the hydraulic cylinder.
7. Repeat steps 1 to 6 to install front swing arms (1)
 8. Angle adjustment handle (10) can be secured to the front or rear frame pin when not in use.

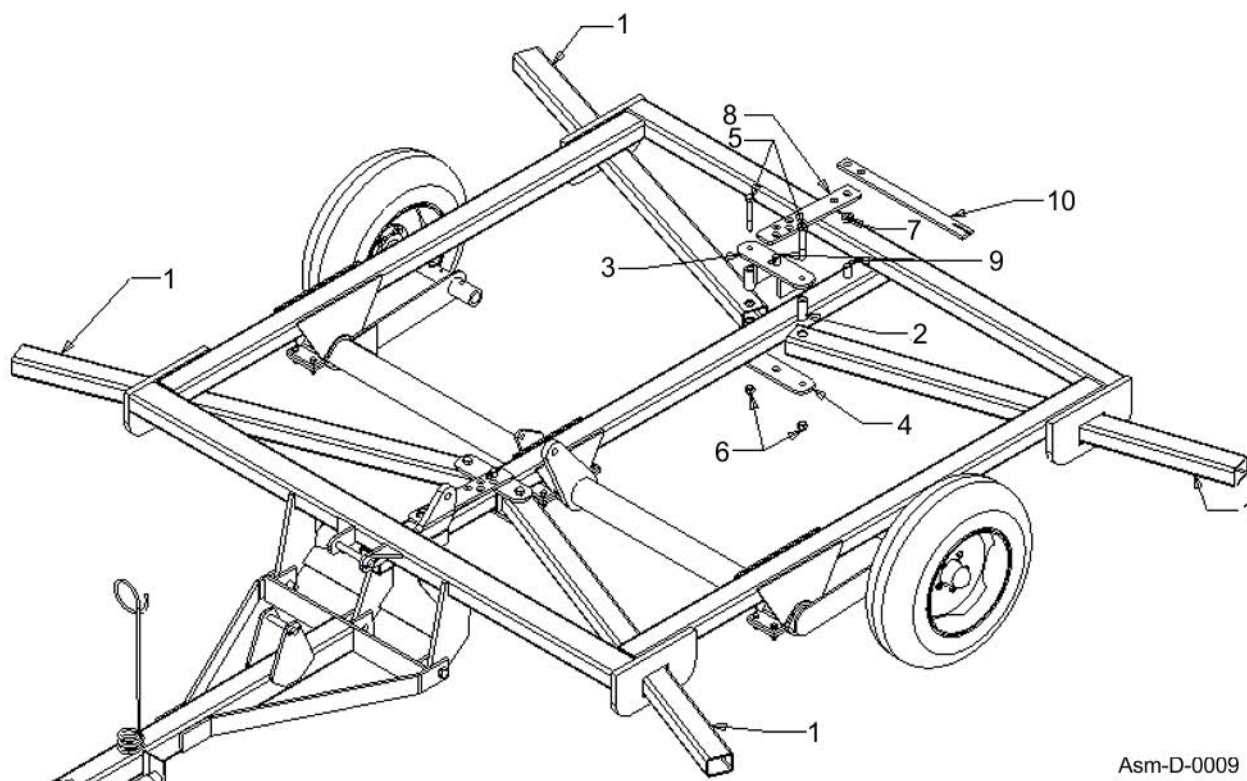

ASSEMBLY

DISC GANG ASSEMBLY

CAUTION

Be careful when working with disc blades as the edges are sharp. Wear gloves when working around disc blades.

WARNING

Keep feet and other body extremities out from under the disc gangs to prevent serious injury or death from crushing or falling blade hazard.

Important

Make sure gang arms (1) are assembled to the disc frame before attaching disc gangs (2) to the swing arms. See "Gang Arm Assembly". Disc gangs (2) come assembled from the factory and include all spacers, discs, bearings and gang hanger brackets. Disc gangs are provided in 7-1" and 9" spacing and with plain or notched disc blades depending on model. If your harrow has two gangs with 7-1/2" spacing, and two gangs with 9" spacing, the 9" spacing always goes in front.

Important

U-Bolts (3) are longer for attaching optional scraper bars and are always located in both holes of the disc gang mounting brackets. Optional scraper kits can be added anytime using the supplied U-Bolts, nuts, and washers.

1. Start with the rear disc gangs. Position them under the rear swing arms.
2. Lower the disc frame gang arms within close proximity of the mounting brackets as follows:
Method #1: Use the hydraulic cylinder to raise the lower the frame with gang tubes attached arms.
Method #2: Raise the front of the frame up to lower the rear gang arms and raise the back of the frame up to lower the front gang arms.
3. Align disc gangs with gang tubes and then drop U-Bolts over the gang tubes into the mounting bracket holes.
4. Continue lowering the swing arms until they are touching the mounting bracket holes.
5. Install 3/4" washers (5) and 3/4" nylocks (4) to the U-Bolts (3). Draw nuts up loosely. **DO NOT TIGHTEN.**
6. Repeat steps 1 to 5 to attach the front disc gangs to the front swing arms.

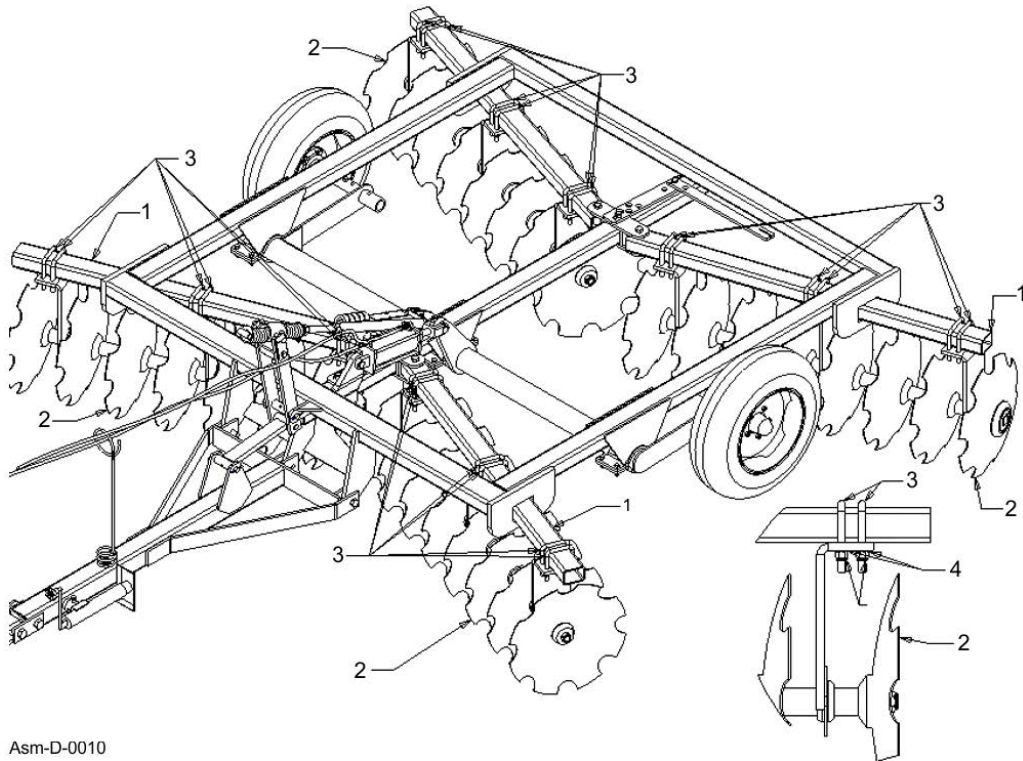

Asm-D-0010

ASSEMBLY

ASSEMBLY

Disc Gang Positioning

The harrow disc gangs are designed to be adjustable to fit your specific environment and application. The following is a good starting point to achieve the best cutting results. Depending on soil type and hardness a wider or narrower gang spread may be needed.

1. Align the front gangs as close together as possible without touching or binding in the middle. Approximately three inches from the gang tube edge to the gang hanger edge is a good starting point. Fine tune each side until the gangs are almost touching and spin freely.
2. The rear gang disc should line up in between the cutting edges of the front disc. To accomplish this, measure six to ten inches from gang tube to gang hanger. Tighten U-Bolts and nylocks to the correct torque.

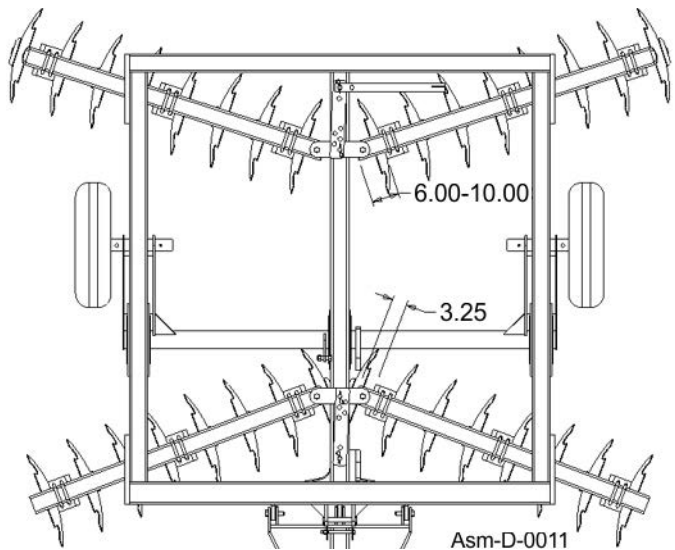

OPTIONAL SCRAPER KITS ASSEMBLY

Scraper kits are sold as an option and can be added at any time. Each kit comes with two different scraper assemblies. Type A is used for left front and right rear. Type B is used on the right front and left rear.

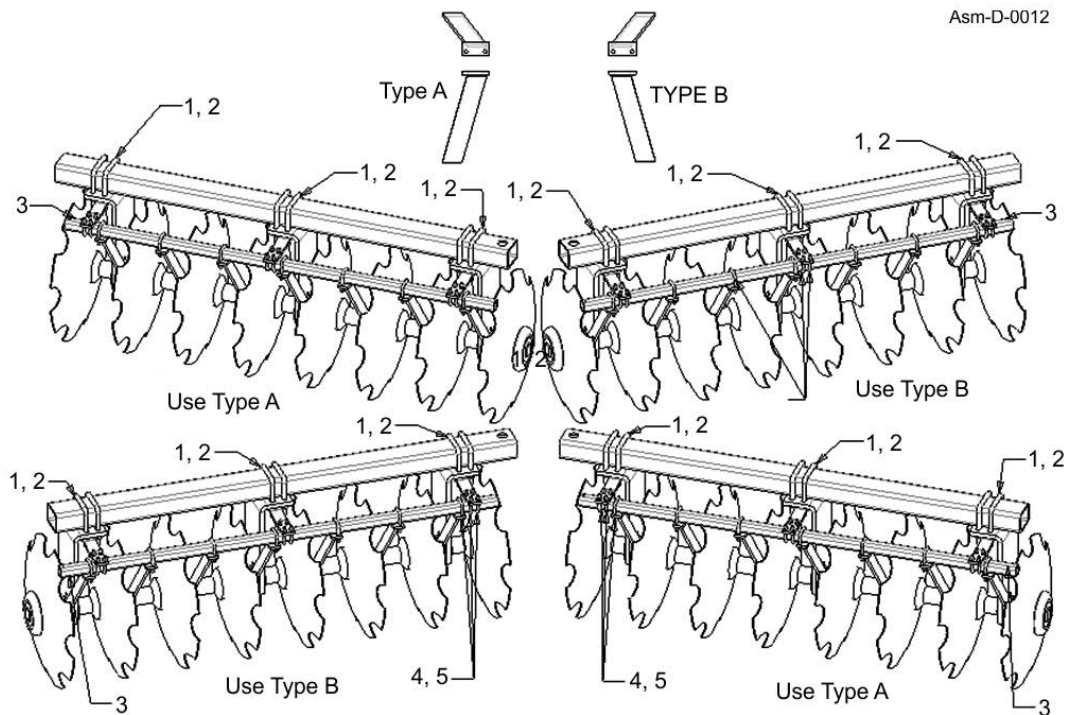

1. Bolt one attachment plate to each gang hanger using the 5/8"x4-1/2" U-Bolts (1) and 5/8" nylocks (2) supplied with the harrow

ASSEMBLY

ASSEMBLY

2. Mount one of the square tubes (3) to the attachment plates on each of the disc gangs using the 3/8"x1-5/8" U-Bolts (4) and 3/8" nylocks (5) supplied with scraper kit. The square tubes are the same and can be mounted on any of the disc gangs. Center the tube leaving approximately the same distance on either side of the outer attachment plates. **Snug the nuts only.** Do not fully tighten the nuts because some adjustment may be needed.
3. Refer to the drawing to identify the "A" and "B" type scraper assemblies. Attach type "A" to the left front and right rear disc gangs using the 3/8"x1-5/8" U-Bolts (4) and 3/8" nylocks (5). The type "A" scraper assembly should be mounted a few inches away from each disc and slant inward toward the concave side of the disc. The scraper should be close to the disc but does not have to touch to be effective. Snug the nuts.
4. Refer to the drawing to identify the "A" and "B" type scraper assemblies. Attach type "B" to the right front and left rear disc gangs using the 3/8"x1-5/8" U-Bolts (4) and 3/8" nylocks (5). The type "B" scraper assembly should be mounted a few inches away from each disc and slant inward toward the concave side of the disc. Snug the nuts. The scraper should be close to the disc but does not have to touch to be effective.
5. Once you have all the scrapers in their approximate place, tighten the nuts that secure the square tube to the attachment plate. Fine tune each scraper's position and tighten to the proper torque.
6. Check the tightness of the scrapers before each use.

OPTIONAL CENTER SWEEP ASSEMBLY

1. Mount the center sweep weldment (1) to the middle frame tube using the attachment plate, 1/2"x5" capscrews and 5/8" nylocks. The center sweep should be as close to the front gangs as possible for best results
2. Fasten the C tine (3) to the center sweep weldment (1) using a 1/2"x1-1/2" capscrew and 1/2" nylocks.
3. Mount the plow point (4) to the C tine (3) using two 3/8"x1-1/2" plow bolts and two 3/8" nylocks

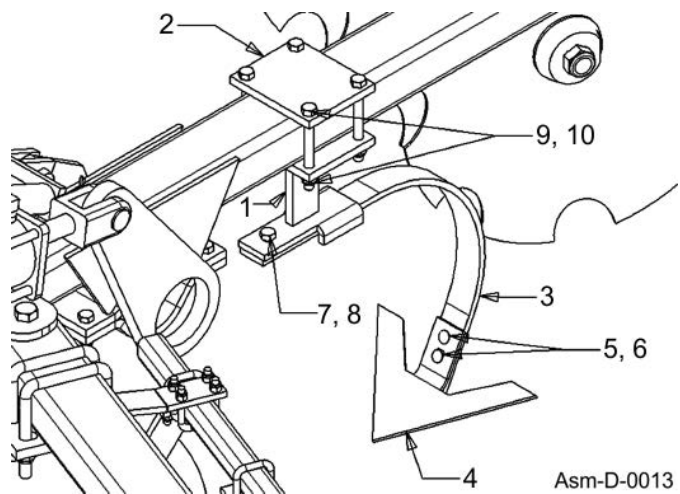

ASSEMBLY

PARKING BRAKE

1. Attach parking jack (1) to jack pivot bracket with detent pin (2). Screw parking jack up and down to position tongue (5) at the correct hook-up height.
2. Pull pin and rotate parking jack counterclockwise 90° and reinsert pin for transporting.

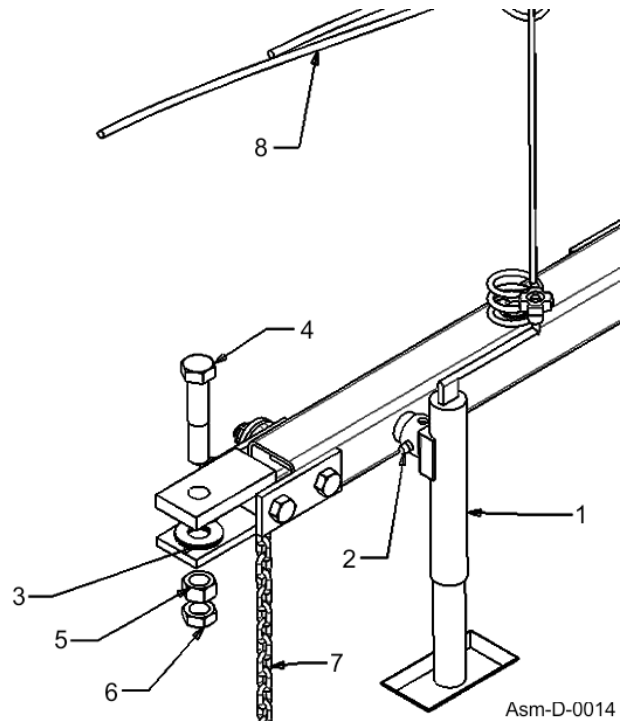

ASSEMBLY

SLOW MOVING VEHICLE SIGN

Attach slow moving vehicle sign (2) to the back of the frame (1) with 1/2"-13x3-1/32"x5 U-Bolt (5), spring lockwashers (4) and 1/2" hex nuts (3). Tighten nuts to the correct torque.

OPERATION SECTION

Operation Section 4-1

OPERATION

DISC HARROW OPERATING INSTRUCTIONS

The tillage implement is manufactured with quality material by skilled workers. This implement is ideal in horticultural, agricultural, or commercial applications.

It is the operator's responsibility to be knowledgeable of all potential operating hazards and to take every reasonable precaution to ensure oneself, others, animals, and property are not injured or damaged by the implement, tractor, or a thrown object. Do not operate the implement if passersby, pets, livestock, or property are directly in front or to the rear of the unit.

This section of the Operator's Manual is designed to familiarize, instruct, and educate safe and proper implement use to the operator. Pictures contained in this section are intended to be used as a visual aid to assist in explaining the operation of a tillage implement. Some pictures may show shields removed for purposes of clarity. The operator must be familiar with the implement and tractor operation and all associated safety practices before operating the implement and tractor. Proper operation of implement, as detailed in this manual, will help ensure years of safe and satisfactory use of the implement.

IMPORTANT: To avoid implement damage, retorque all bolts after the first 10 hours of operation. Refer to the Torque Chart at the end of the Maintenance Section to ensure bolts are properly tightened.

READ AND UNDERSTAND THE ENTIRE OPERATING INSTRUCTIONS AND SAFETY SECTION OF THIS MANUAL AND THE TRACTOR MANUAL BEFORE ATTEMPTING TO USE THE TRACTOR AND IMPLEMENT. If you do not understand any of the instructions, contact your nearest authorized dealer for a full explanation. Pay close attention to all safety signs and safety messages contained in this manual and those affixed to the implement and tractor. *OPS-U- 0001str*

READ, UNDERSTAND, and FOLLOW the following Safety Messages. Death or serious injury may occur unless care is taken to follow the warnings and instructions stated in the Safety Messages. Always use good common sense to avoid hazards. (SG-2str)



OPERATION

1. STANDARD EQUIPMENT AND SPECIFICATIONS

	DHP8	DHP10	DHP12
Hitch Type	Pull-Type w/Clevis & Hole for 1-1/4" Pin		
Blade Spacing	7-1/2", 9" or combination	7-1/2", 9" or combination	7-1/2", 9" or combination
Blade Type	Notched	Notched	Notched
Blade Size	20" or 22"	20" or 22"	20" or 22"
Trasnport Width	8' - 10'	8' - 10'	8' - 10'
Cultivation Width	8' 6"	10' 6"	12'
Bearing Type	Triple Lip Sealed Ball Bearings		
No. of Bearings	8	12	12
Mainframe Width	60"	93-1/2"	93-1/2"
Drawbar HP Requirements	40 - 65 HP	45 - 100 HP	55 - 100 HP
Gang Tube	3" x 1-1/2"	3" x 2"	4" x 3"
Gang Axle	1-1/8" Square High Carbon Steel		
Parking Jack	Standard	Standard	Standard
Forward Gang Angle Adjustment	15, 16.5, 18, 19.5, 21 Degrees		
Rear Gang Angle Adjustment	12, 13.5, 15, 16.5, 18 Degrees		
Front to Rear Leveling System	Manual Crank Adjustment		
Depth Control	Cylinder Stroke Control Spacers		
Hydraulic Cylinder	3-1/2" x 8" ASAE Hydraulic Cylinder		
Transport Tires and Wheels	Two 9.5L x 15 Tires on 15" x 6" - 5 Bolt Wheels		

AVAILABLE OPTIONS

Disc Scrapers, Center Sweep Kit, Dual Wheel Transport Kit

OPERATION

2. OPERATOR REQUIREMENTS

Safe operation of the unit is the responsibility of a qualified operator. A qualified operator has read and understands the implement and tractor Operator's Manuals and is experienced in implement and tractor operation and all associated safety practices. In addition to the safety messages contained in this manual, safety signs are affixed to the implement and tractor. If any part of the operation and safe use of this equipment is not completely understood, consult an authorized dealer for a complete explanation.

If the operator cannot read the manuals for themselves or does not completely understand the operation of the equipment, it is the responsibility of the supervisor to read and explain the manuals, safety practices, and operating instructions to the operator.

Safe operation of equipment requires that the operator wear approved Personal Protective Equipment (PPE) for the job conditions when attaching, operating, servicing, and repairing the equipment. PPE is designed to provide operator protection and includes the following safety wear:

PERSONAL PROTECTIVE EQUIPMENT (PPE)

- Always Wear Safety Glasses (with side shields marked to comply with ANSI Z87)
- Hard Hat
- Steel Toe Safety Footwear
- Gloves
- Hearing Protection
- Close Fitting Clothing
- Respirator or Filter Mask (depends on operating conditions)

OPS-U- 0002str

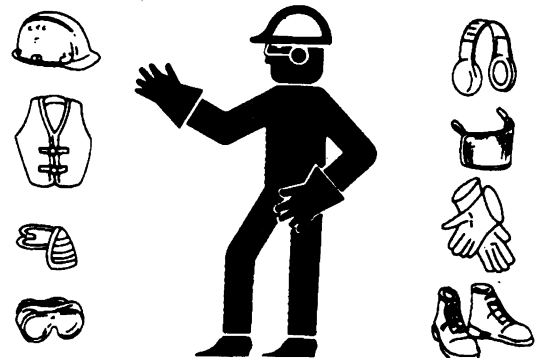

DO NOT use drugs or alcohol immediately before or while operating the Tractor and Implement. Drugs and alcohol will affect an operator's alertness and coordination and therefore affect the operator's ability to operate the equipment safely. Before operating the Tractor or Implement, an operator on prescription or over-the-counter medication must consult a medical professional regarding any side effects of the medication that would hinder their ability to operate the Equipment safely. NEVER knowingly allow anyone to operate this equipment when their alertness or coordination is impaired. Serious injury or death to the operator or others could result if the operator is under the influence of drugs or alcohol. (SG-27) str

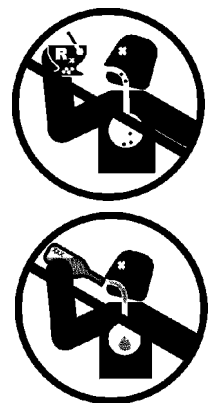

3. TRACTOR REQUIREMENTS

Operating the cultivator with a tractor that does not meet the following requirements may cause tractor or implement damage and be a potential danger to the operator and passersby..

Tractor Requirements and Capabilities

- ASABE approved Roll-Over Protective Structure (ROPS) or ROPS cab and seat belt.
- Tractor Safety Devices Slow Moving Vehicle (SMV) emblem, lighting, PTO master shield

OPERATION

- Tractor Horsepower Minimum DHP8 40-65 hp, DHP10 45-100 hp, DHP 55-100 hp
- Hitch Pull-Type w/Clevis and hole for 1-1/4" Pin

3.1 ROPS and Seat Belt

The tractor must be equipped with a Roll-Over-Protective-Structure (ROPS) (tractor cab or roll-bar) and seat belt to protect the operator from falling off the tractor, especially during a roll over where the driver could be crushed and killed. Only operate the tractor with the ROPS in the raised position and seat belt fastened. Tractor models not equipped with a ROPS and seat belt should have these life saving features installed by an authorized dealer. OPS-U- 0003str



Operate this Equipment only with a Tractor equipped with an approved roll-over-protective system (ROPS). Always wear seat belts. Death or serious injury could result from falling off the tractor, particularly during a turnover when the operator could be pinned under the ROPS. (SG-7) str



3.2 Tractor Safety Devices

If transporting or operating the tractor and implement near a public roadway, the tractor must be equipped with proper warning lighting and a Slow Moving Vehicle (SMV) emblem which are clearly visible from the rear of the unit. Lights and a SMV emblem must be equipped directly on implements if the visibility of the tractor warning signals are obscured.

Maintain all manufacturer equipped safety shields and guards. Always replace shields and guards that were removed for access to connect, service, or repair the tractor or implement. Never operate the tractor PTO with the PTO master shield missing or in the raised position. OPS-U- 0004str

3.3 Tractor Horsepower

The power required to operate an implement is determined by the tractor PTO horsepower. For most operating conditions, implement requires a tractor with at least 40 hp for DHP8, 45 hp for DHP10 and 55 hp for DHP12. Operating the implement with a tractor that does not have adequate power may damage the tractor engine. Exceeding required HP may cause implement damage by overpowering the unit in heavy cutting conditions.

3.4 Front End Weight

A minimum of 20% total tractor weight must be maintained on the tractor front end at all times. Front end weight is critical to maintain steering control and to prevent the tractor from rearing up while driving. If the front end is too light, add weight until a minimum of 20% total weight is reached on the front tires. Front weights and weight carriers can be purchased through an authorized tractor dealership. OPS-U-0005 str

OPERATION

OPERATION

4. GETTING ON AND OFF THE TRACTOR

Before getting onto the tractor, the operator must read and completely understand the implement and tractor operator manuals. If any part of either manual is not completely understood, consult an authorized dealer for a complete explanation. OPS-U- 0007str



Do not mount or dismount the Tractor while the tractor is moving. Mount the Tractor only when the Tractor and all moving parts are completely stopped. Dismounting a moving power unit can result in a crushing hazard that can cause death or serious injury. (SG-12) str



4.1 Boarding the Tractor

Use both hands and equipped handrails and steps for support when boarding the tractor. Never use control levers for support when mounting the tractor. Seat yourself in the operator's seat and secure the seat belt around you.

Never allow passengers to ride on the tractor or attached equipment. Riders can easily fall off and be seriously injured or killed from falling off and being ran over. It is the operator's responsibility to forbid all extra riders at all times. OPS-U- 0008str



Never allow children to operate, ride on, or come close to the Tractor or Implement. Usually, 16-17 year-old children who are mature and responsible can operate the implement with adult supervision, if they have read and understand the Operator's Manuals, been trained in proper operation of the tractor and Implement, and are physically large enough to reach and operate the controls easily. (SG-11) str



Never allow children or other persons to ride on the Tractor or Implement. Falling off can result in death or serious injury. (SG-10)str



4.2 Dismounting the Tractor

Before dismounting, park the tractor and implement on a reasonably level surface, apply the parking brake, idle the engine down, disengage the PTO, and lower the implement to the ground. Shut down the tractor engine according to the operator's manual, remove the key, and wait for all motion to completely stop. Never leave the seat until the tractor, its engine and all moving parts have come to a complete stop.

Use hand rails and steps when exiting the tractor. Be careful of your step and use extra caution when mud, ice, snow or other matter has accumulated on the steps or hand rails. Use all handrails and steps for support and never rush or jump off the tractor. OPS-U- 0009 str



BEFORE leaving the tractor seat lower the implement, set the parking brake and/or set the tractor transmission in parking gear, disengage the PTO, stop the engine, remove the key, and wait for all moving parts to stop. Place the tractor shift lever into a low range or parking gear to prevent the tractor from rolling. Never dismount a Tractor that is moving or while the engine is running. Operate the Tractor controls from the tractor seat only. (SG-9)str

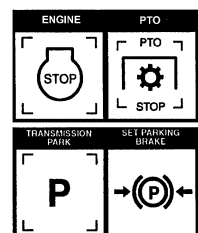

OPERATION

5. STARTING THE TRACTOR

The operator must have a complete understanding of the placement, function, and operational use of all tractor controls before starting the tractor. Review the tractor operator's manual and consult an authorized dealer for tractor operation instructions if needed.

Essential Tractor Controls:

- Locate the light control switch.
- Locate the engine shut off control.
- Locate the brake pedals and the clutch.
- Locate the PTO control.
- Locate the 3-point hitch control lever.
- Locate the hydraulic remote control levers

Before starting the tractor ensure the following:

- Conduct all pre-start operation inspection and service according to the tractor operator's manual.
- Make sure all guards, shields, and other safety devices are securely in place.
- The parking brake is on.
- The PTO control lever is disengaged.
- The 3-point hitch control lever is in the lowered position.
- The hydraulic remote control levers are in the neutral position.
- The tractor transmission levers are in park or neutral.

Refer to the tractor owner's manual for tractor starting procedures. Only start the tractor while seated and belted in the tractor operator's seat. Never bypass the ignition switch by short circuiting the starter solenoid. After the tractor engine is running, avoid accidental contact with the tractor transmission to prevent sudden and unexpected tractor movement. OPS-U-0028str



Never run the Tractor engine in a closed building or without adequate ventilation. The exhaust fumes can be hazardous to your health. (SG-23) str



Start tractor only when properly seated in the Tractor seat. Starting a tractor in gear can result in death or serious injury. Read the Tractor operators manual for proper starting instructions. (SG-13) str



OPERATION

6. CONNECTING THE IMPLEMENT TO THE TRACTOR

Use extreme caution when connecting the Implement to the tractor. The implement should be securely resting at ground level or setting on blocks. Keep hands and feet from under the implement frame and clear of pinch points between the tractor hitch arms and implement pins.

DANGER

Crushing hazard between tractor and implement can occur. Do not allow anyone to stand between tractor and implement while backing up to an implement, Do not operate hydraulic 3-point lift controls while someone is directly behind the tractor or near the Disc Harrow.

DANGER

Always shut the Tractor completely down, place the transmission in park, and set the parking brake before you or anyone else attempts to connect or disconnect the Implement and Tractor hitches. (S3PT-15) str

Important

Identifies special instructions or procedures that, if not strictly observed, could result in damage to, or destruction of the machine, attachments or the environment.

6.1 Connecting the Disc Harrow

1. Make certain parking jack (1) is properly attached to implement hitch and secured with detent pin (2).
2. Pivot clevis hitch up horizontally..
3. Back tractor within close proximity of clevis.
4. Raise or lower parking hack (1) to align clevis with tractor drawbar. Drawbar should fit between lower and upper plates of clevis.
5. Back tractor up to implement hitch until holes in drawbar and clevis are aligned.
6. Insert two 1-1/4" flatwashers (3) equally above and below tractor drawbar until both spaces between drawbar and clevis plates are filled This will reduce drawbar wear.
7. Insert 1-1/4"-7 x 6-1/2" GR5 hex bolt (4 through bottom clevis hole, 1-1/4" washers (3), drawbar, remaining 1-1/4" washers (3) and out through lower clevis hole. Secure hex bolt with hex nut (5) and jam nut (6). Tighten hex nut snugly to remove all play and then back one-quarter turn. Tighten jam nut tight against hex nut.
8. Lower parking jack (1) until implement weight is removed from parking jack. Rotate parking jack counterclockwise 90 degrees and reinsert detent pin for storage.
9. Attach hitch safety chain (7) to tractor. Adjust chain length to remove all slack except what is necessary to permit turning. Lock chain hook securely to the safety chain.
10. Attach hydraulic hoses (8) to tractor hydraulic system.
11. Pin tractor drawbar in fixed center position.

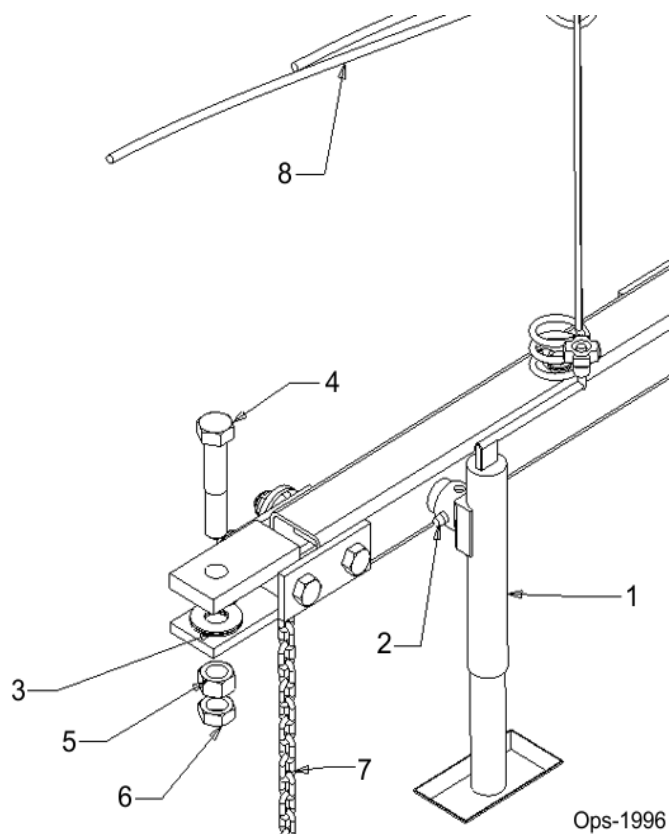

Ops-1996

OPERATION

6.2 Slow Moving Vehicle Sign

1. Attach SMV mounting spade (2) to the welded mounting bracket (3) using two, 5/16"x1-1/2" carriage head bolts and two 5/16" Nylock nuts (6 &7).
2. Secure SMV sign (1) to mounting spade (2) with two 1/4"x1/2" hex head bolts and two 1/4" nylocks nuts (4 & 5)

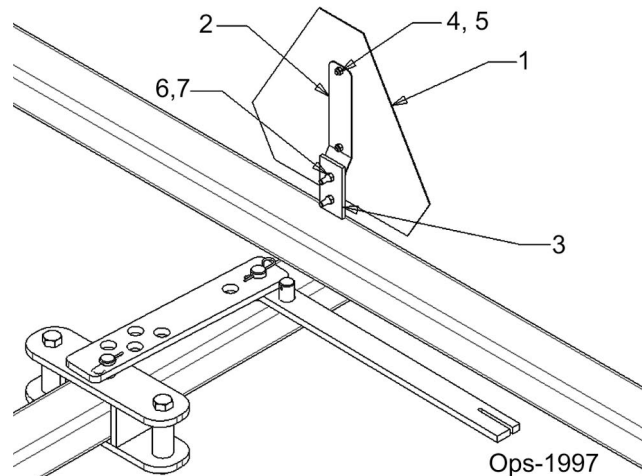

6.3 Bleeding Hydraulic Lines



Do not operate this Equipment with hydraulic oil or fuel leaking. Oil and fuel are explosive and their presence could present a hazard. Do not check for leaks with your hand! High-pressure oil streams from breaks in the line could penetrate the skin and cause tissue damage including gangrene. To check for a hose leak, SHUT the unit ENGINE OFF and remove all hydraulic pressure. Wear oil impenetrable gloves, safety glasses and use cardboard to check for evidence of oil leaks. If you suspect a leak, REMOVE the HOSE and have it tested at a Dealer. If oil does penetrate the skin, have the injury treated immediately by a physician knowledgeable and skilled in this procedure. (SG-15) str



1. With implement lowered to the ground, remove connecting pin from rod end of cylinder. Support cylinder in a vertical position with rod end up. Cycle hydraulic system to extend and retract cylinder. Repeat this process 2 times.
2. Crack fitting at the rod end of cylinder and apply hydraulic pressure until air free oil leaks from fitting and the re-tighten.
3. Support cylinder in a vertical position with base end up and repeat bleeding process on rod end cylinder fitting.
4. Pin clevis on rod end. Slowly cycle disc harrow to transport position while checking to make sure hydraulic hoses are not pinched in the process.

OPERATION

7. PRE-FIELD ADJUSTMENTS

7.1 Side to Side Leveling

Check tire pressure. All tires should have equal pressure. Unequal tire pressure will allow the disc to dig in deeper on the side with the lowest tire pressure. This will make the Disc Harrow pull at an angle to the direction of travel.

7.2 Front or Rear Leveling



Total compressed length of leveling springs (4) is 12-1/2" between flatwashers. Never adjust nuts (5) to compress springs under 12-1/2". Compressing springs too tight can damage the spring adjuster resulting in flying projectiles and sudden drop of the Disc Harrow.



Do not fully unscrew threaded rod (2) from threaded rod tube (6). Unscrewing the rod will result in a sudden drop of the front disc gangs. Maximum allowable exposed rod (5) between nuts (4) and adjuster tube (6) is 15".

Most operating problems are due to unequal pressure and penetration of the front and rear gangs. Preset the harrow with the rear disc blades almost touching the ground and the front disc blades approximately 2 inches off the ground as follows:

1. Lower Disc Harrow until rear disc blades are almost touching the ground. Raise implement slightly and then add stroke control spacers (1) to the cylinder rod until rod is full.
2. Lower machine until cylinder is pressing against the stroke control spacers.
3. Turn spring adjuster to position the front disc blades approximately 2 inches above the rear disc blades as follows:
 - Turn threaded rod (2) clockwise with adjusting lever (3) to lower the rear disc blades.
 - Turn threaded rod (2) counterclockwise with adjusting lever (3) to raise the rear disc blades.

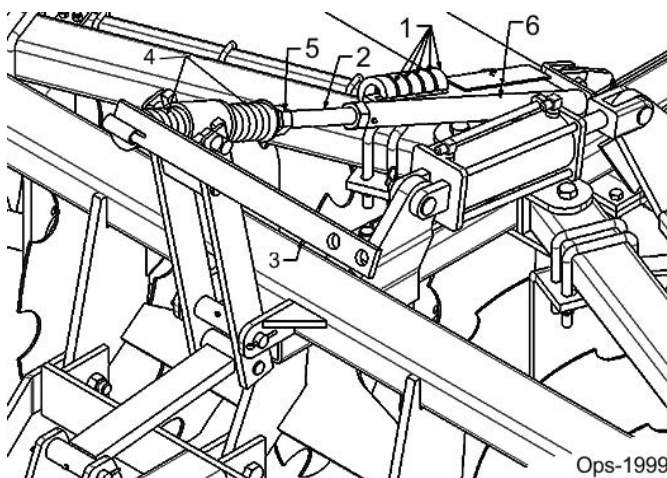

7.3 Disc Gang Adjustment



Keep everyone clear of gang arm hanger brackets while adjusting disc gang angles. Body extremities can become pinched in the bracket openings.

It is best if the disc gang angles are set at the smallest angle required to do the job. Refer to values provided when adjusting the front disc gang angle and when adjusting the rear disc gang angle. A good starting angle is 18 degrees for the front gangs.

Make adjustments with the disc gangs off the ground:

1. Remove hairpins (1) from angle adjuster and angle frame pin.
2. Remove angle bar (2)
3. Place hole in adjusting lever (3) over angle adjuster pin (4). Make sure pin (5) on adjusting lever is facing up.
4. Place one of the holes in angle bar (2) over pin (5).
5. Determine which hole to select in the angle bar when setting disc gangs to the desired angle.

OPERATION

- Pull or push on lever handle (3) to move disc gangs forward or rearward until selected hole in angle bar aligns with pin (4).
- Remove adjusting lever (3) and place stabilizing bar (2) on pin (4).
- Replace hairpin cotters (1).
- Repeat steps 1 to 8 for the front gangs.
- Store adjusting lever under one of the stabilizing bars when completed. Make sure all hairpins (1) have been replaced.

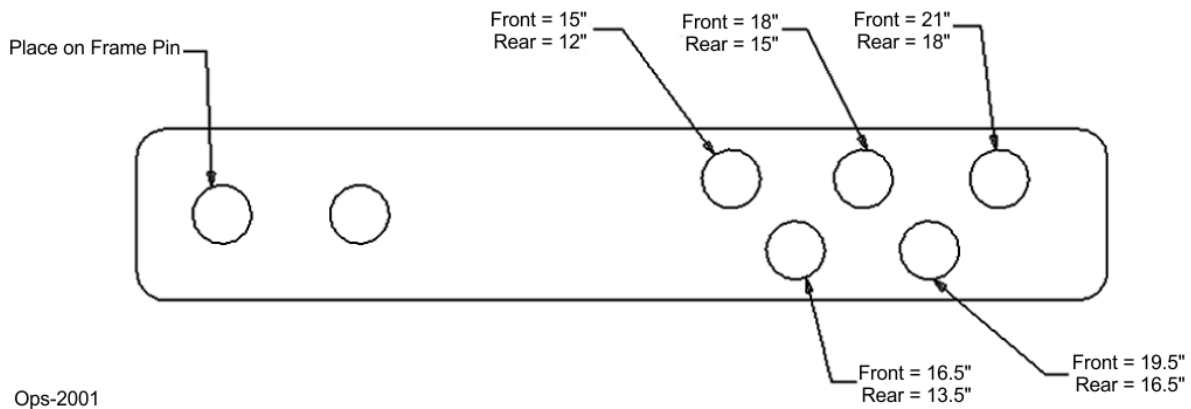
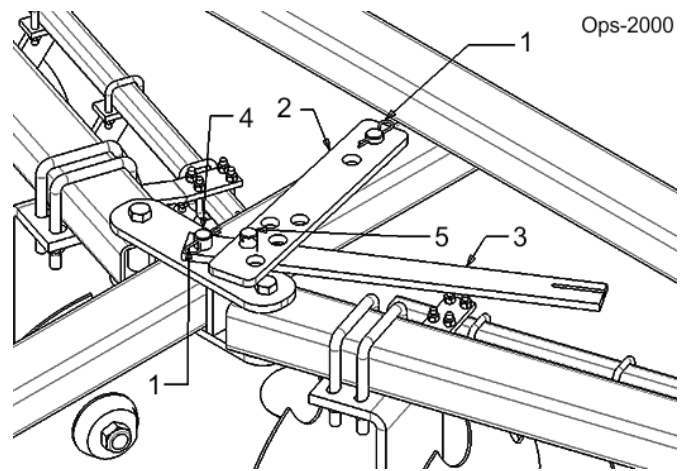

8. IN-FIELD ADJUSTMENTS

CAUTION

Be careful when working with disc blades as the edges are sharp. Wear gloves when working around disc blades.

CAUTION

Damage to the harrow can occur if it is not lifted out of the ground before making sharp turns.

Important

Make sure tractor drawbar is pinned in the center position and tractor 3-point arms are positioned so that they will not make contact with the disc harrow hitch.

Important

The disc harrow tires can be raised off the ground to add weight to the disc gangs. However, DO NOT add any additional weight to the disc harrow in an attempt to make the disc blades sink into the ground deeper, instead make additional passes over the worked area.

Important

Each adjustment affects another, therefore make only one adjustment at a time and then test that adjustment before continuing. Make each trial run with tractor in the same gear and at the same speed. Varying tractor speed while making adjustments will only make adjusting the disc harrow harder.

OPERATION

8.1 Hydraulic Cylinder Depth Adjustment

1. Remove all stroke control spacer (4 & 5) from the hydraulic cylinder.
2. Lower disc harrow to desired working depth and travel forward. Your travel speed will be determined by soil conditions.
3. When working depth is achieved, stop tractor, shut tractor engine off, and remove switch key.
4. Select required size and number of stroke control spacers (3) that will fit between hydraulic cylinder and rod eye clevis. The following spacers are available:
 - Two 1" Spacers
 - One 1-1/4" Spacer
 - One 1-1/2" Spacer
 - One 1-3/4" Spacer
5. Return to the tractor and raise the disc harrow up. Once fully raised, turn tractor engine off and remove switch key.
6. Install preselected stroke control spacers on the cylinder rod.
7. Lower disc harrow against installed stroke control spacer. Recheck working depth. If needed, adjust size and quantity of stroke control spacers until desired working depth is achieved.

8.2 Disc Gang Angle

Increasing the disc gang angle will help the disc harrow to penetrate the soil and remove vegetation. However, too much angle can cause the disc harrow to operate erratically. Therefore, it is best if the disc gang angles are set at the smallest angle required to do the job. Make sure the angle of the front disc gangs is 3 degrees more than the rear disc gangs. See Troubleshooting Section for helpful solutions to setting the disc gang angles.

8.3 Disc Leveling Front to Rear

The truest way to level your disc from front to rear is to observe behind the center of the disc harrow. In most soil conditions, a slight ridge in the center is actually a level operation. More air pockets will form where soil is thrown against each other causing a small ridge to form that will disappear after a soaking rain.

1. If unit is leaving a significant ridge in the center, raise disc rear gangs by turning threaded rod counterclockwise.
2. If unit is leaving a furrow (valley) in the center, lower the rear disc gangs by turning threaded rod clockwise.
3. See Troubleshooting Section for helpful solutions to leveling the disc harrow.

8.4 Disc Blade Replacement

When replacing notched disc blades, assemble the disc blades in a spiral pattern. Order 3/8" thick washer(s) from your nearest Bush Hog Dealer if axle nut(s) runs out of threads before the disc blades are tight on the axle.

OPERATION

9. PRE-OPERATION INSPECTION AND SERVICE

Before each use, a pre-operation inspection and service of the implement and tractor must be performed. This includes routine maintenance and scheduled lubrication, inspecting that all safety devices are equipped and functional, and performing needed repairs. DO NOT operate the unit if the pre-operation inspection reveals any condition affecting safe operation. Perform repairs and replacement of damaged and missing parts as soon as noticed. By performing a thorough pre-operation inspection and service, valuable down time and repair cost can be avoided. OPS-U-0029str



Periodically inspect all moving parts for wear and replace when necessary with authorized service parts. Look for loose fasteners, worn or broken parts, and leaky or loose fittings. Make sure all pins have cotter pins and washers. Serious injury may occur from not maintaining this machine in good working order. (SG-21)str

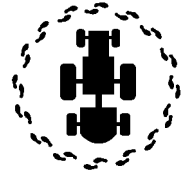

9.1 Tractor Pre-Operation Inspection/Service

Refer to the tractor operator's manual to ensure a complete pre-operation inspection and scheduled service is performed according to the manufacturers recommendations. The following are some of the items that require daily service and inspection:

- Tire condition/air pressure
- Wheel lug bolts
- Steering linkage
- PTO shield
- SMV sign is clean and visible
- Tractor's lights are clean and functional
- Tractor Seat belt is in good condition
- ROPS is in the raised position
- No tractor oil leaks
- Radiator free of debris
- Engine oil level and condition
- Engine coolant level and condition
- Power brake fluid level
- Power steering fluid level
- Fuel condition and level
- Sufficient lubrication at all lube points
- Air filter condition OPS-U-0030 str



OPERATION

9.2 Implement Pre-Operation Inspection/Service

Before each implement use, a complete inspection and service is required to ensure the implement is in a good and safe working condition. Damaged and/or broken parts should be repaired and/or replaced immediately. To ensure the implement is ready for operation, conduct the following. *OPS-T-0002 str*

The operator's manual and safety signs affixed on the unit contain important instructions on the safe and proper use of the equipment. Maintain these important safety features on the implement in good condition to ensure the information is available to the operator at all times.

- Ensure the manual canister is secured to the equipment with the operator's manual inside.
- Ensure all safety signs are in place and legible. Replace missing, damaged, and illegible decals. *OPS-U- 0011 str*



- Perform scheduled lubrication as detailed in the maintenance section.
- Ensure all decals are in place and legible.
- Ensure that a properly rated safety tow chain is equipped securing the implement to the tractor.
- Before operation check disc blades and spools for breakage or cracking and replace if needed.
- Inspect Disc Gang and grease after ever 8 hours of use.
- Inspect all bolts and screws and tighten to the recommended torque.
- Before operation check disc blades and spools for breakage or cracking and replace if needed.
- Inspect Disc Gang and grease after every 8 hour use.
- Inspect all bolts and screws and tighten to the recommended torque.
- Inspect tire condition, wheel bearings, and lug nut torque.

OPERATION

TRACTOR PRE-OPERATION INSPECTION



Tractor ID# _____ Make: _____

Date: _____ Shaft: _____



Before conducting the inspection, make sure the tractor engine is off, all rotation has stopped and the tractor is in park with the parking brake engaged. Make sure the mower is resting on the ground or securely blocked up and all hydraulic pressure has been relieved.

OPERATION

Item	Condition at Start of Shift	Specific Comments if not OK
The flashing lights function properly		
The SMV Sign is clean and visible		
The tires are in good condition with proper pressure		
The wheel lug bolts are tight		
The tractor brakes are in good condition		
The steering linkage is in good condition		
There are no visible oil leaks		
The hydraulic controls function properly		
The ROPS or ROPS Cab is in good condition		
The seatbelt is in place and in good condition		
The 3-point hitch is in good condition		
The drawbar pins are securely in place		
The PTO master shield is in place		
The engine oil level is full		
The brake fluid level is full		
The power steering fluid level is full		
The fuel level is adequate		
The engine coolant fluid level is full		
The radiator is free of debris		
The air filter is in good condition		

Operator's Signature: _____

DO NOT OPERATE an UNSAFE TRACTOR or MOWER

OPERATION

DISC HARROW PRE-OPERATION INSPECTION



Blade ID# _____

Date: _____

Make: _____

Shift: _____



Before conducting the inspection, make sure the tractor engine is off, all rotation has stopped and the tractor is in park with the parking brake engaged. Make sure the blade is resting on the ground or securely blocked up and all hydraulic pressure has been relieved.

Item	Condition at Start of Shift	Specific Comments if not OK
The Operator's Manual has been read and understood		
All safety decals are in place and legible		
The hitch connection pins are properly retained		
There are no cracks in the Hitch		
All frame bolts are in place and properly tightened		
The disc swing, angle pins are properly lubricated and retained		
The Gang Axles are clear of mud and debris		
The Disc and Gang attachment bolts are in place		
The Disc edges are not chipped, cracked or bent		

Operator's Signature: _____

DO NOT OPERATE an UNSAFE TRACTOR or IMPLEMENT

OPERATION

10. DRIVING THE TRACTOR AND IMPLEMENT

Safe tractor transport requires the operator possess a thorough knowledge of the model being operated and precautions to take while driving with an attached implement. Ensure the tractor has the capacity to handle the weight of the implement and the tractor operating controls are set for safe transport. To ensure safety while driving the tractor with an attached implement, review the following. OPS-U- 0012str



Never run the Tractor engine in a closed building or without adequate ventilation. The exhaust fumes can be hazardous to your health. (SG-23) str



Transport only at speeds where you can maintain control of the equipment. Serious accidents and injuries can result from operating this equipment at high speeds. Understand the Tractor and Implement and how it handles before transporting on streets and highways. Make sure the Tractor steering and brakes are in good condition and operate properly.



Before transporting the Tractor and Implement, determine the proper transport speeds for you and the equipment. Make sure you abide by the following rules:

Test the tractor at a slow speed and increase the speed slowly. Apply the Brakes smoothly to determine the stopping characteristics of the Tractor and Implement. As you increase the speed of the Tractor the stopping distance increases. Determine the maximum transport speed not to exceed 20 mph (30 kph) for transporting this equipment.

Test the equipment at a slow speed in turns. Increase the speed through the turn only after you determine that the equipment can be operated at a higher speed. Use extreme care and reduce your speed when turning sharply to prevent the tractor and implement from turning over. Determine the maximum turning speed for you and this equipment before operating on roads or uneven ground.

Only transport the Tractor and Implement at the speeds which allow you to properly control the equipment.

Be aware of the operating conditions. Do not operate the Tractor with weak or faulty brakes or worn tires. When operating down a hill or on wet or rain slick roads, the braking distance increases: use extreme care and reduce your speed. When operating in traffic always use the Tractor's flashing warning lights and reduce your speed. Be aware of traffic around you and watch out for the other guy. (SG-19)str



OPERATION

10.1 Starting the Tractor

The procedure to start the tractor is model specific. Refer to the tractor operator's manual for starting procedures for your particular tractor. Consult an authorized dealer if the starting procedure is unclear. Ensure the 3-point control lever is in the lowered position and the PTO is disengaged before starting the tractor. OPS-U-0033str



10.2 Brake and Differential Lock Setting

Make sure the tractor brakes are in good operating condition. Tractor brakes can be set to operate independently allowing single rear wheel braking action or locked together to provide simultaneous rear wheel braking. FOR MOST DRIVING AND OPERATING CONDITIONS, THE BRAKE PEDALS SHOULD BE LOCKED TOGETHER TO PROVIDE THE MOST EFFECTIVE BRAKING ACTION.

Always disengage the tractor differential lock when turning. When engaged the differential lock will prevent or limit the tractor from turning. During normal cutting conditions, locking the differential provides no benefit and should not be used.



▲WARNING

Be aware of the operating conditions. Do not operate the Tractor with weak or faulty brakes. When operating down a hill or on wet or rain slick roads, the braking distance increases. Use extreme care and reduce your speed in these conditions. When operating in traffic, always use the Tractor's flashing warning lights and reduce your speed. Be aware of traffic around you and watch out for the other guy. OPS-U- 0013 str

OPERATION

10.3 Driving the Tractor and Implement

Start off driving at a slow speed and gradually increase your speed while maintaining complete control of the tractor and unit. Moving slowly at first will also prevent the tractor from rearing up and loss of steering control. The tractor should never be operated at speeds that cannot be safely handled or which will prevent the operator from stopping quickly during an emergency. If the power steering or engine ceases operating, stop the tractor immediately as the tractor will be difficult to control.

Perform turns with the tractor and units at slow speeds to determine how the tractor with an attached cultivator handles a turn. Determine the safe speed to maintain proper control of the tractor when making turns. When turning with a towed implement, the overall working length of the unit is increased. Allow additional clearance for the units when turning.

To avoid overturns, drive the tractor with care and at safe speeds, especially when operating over rough ground, crossing ditches or slopes, and turning corners. Tractor wheel tread spacing should be increased when working on inclines or rough ground to reduce the possibility of tipping.

Use extreme caution when operating on steep slopes. Keep the tractor in a low gear when going downhill. DO NOT coast or free-wheel downhill. *OPS-C-0002 str*

11. OPERATING THE TRACTOR AND IMPLEMENT

THE OPERATOR MUST COMPLETELY UNDERSTAND HOW TO OPERATE THE TRACTOR AND IMPLEMENT AND ALL CONTROLS BEFORE ATTEMPTING TO OPERATE.

The operator must read and understand the Safety and Operation Sections of the implement and tractor operator's manuals. These manuals must be read and explained to any operator who cannot read. Never allow someone to operate the implement and tractor without complete operating instructions.

Before starting any operation, the operator must become familiar with the area to be worked in and any obstacles and hazards contained within to ensure safety to the operator, bystanders, and equipment. Special attention should be paid to foreign debris, rough terrain, steep slopes, and passersby and animals in the area. *OPS-U- 0015 str*



Many varied objects, such as wire, cable, rope, or chains, can become entangled in the rotating parts of the Implement. These objects could then swing outside the housing at great velocity. Such a situation is extremely hazardous and could result in serious injury or even death. Inspect the area for such objects before working in the area. Remove any such objects from the site. Never allow the implement to contact such objects. *(STL-6) str*

11.1 Field Operating Instructions

Final adjustments will need to be made while operating the disc harrow in the field. See "In Field Adjustments" for final adjusting instructions

NOTE: *Disc Harrows with disc blades spaced 7-1/2" apart are primarily used to pulverize soil. They work best in tilled soil. Disc blades spaced 9" apart are recommended for cutting un-tilled soil.*



Damage to the harrow can occur if it is not lifted out of the ground before making sharp turns.

OPERATION

1. Raise unit out of the ground to make sharp turns. When making sharp turns, make sure the tractor tires do not make contact with the disc harrow hitch.
2. Do not disc in reverse (traveling backwards), The disc harrow is designed to work soil while traveling forward only. Damage to the harrow may occur.
3. Do not back disc harrow into corners and tight places with disc gangs down. Instead, lift unit up and back unit into the corner or tight area. Lower disc to the ground and then proceed forward.
4. It is best to work ground traveling with a ditch and not across. Raise disc harrow up to cross shallow ditches straight on at 90 degrees. Crossing a ditch on the diagonal can damage the disc and/or tractor especially if a disc gang on one side digs into the ground. Never cross deep ditches.

12.DISCONNECTING THE CULTIVATOR FROM THE TRACTOR

Before disconnecting the cultivator, all movement must cease. Move the implement to a level storage location and lower the unit to the ground. If the cultivator is not resting securely on the ground, block the implement up securely before attempting to disconnect it from the tractor.

DANGER

Use extreme care to keep feet and hands from under the implement and clear of any pinch points caused by the tractor hitch arms and implement pins. Never stand or allow another person to stand between a running Tractor and the Implement when disconnecting the Implement from the Tractor. Always shut the Tractor off completely and set the parking brake before attempting to disconnect the Implement pins from the Tractor hitch.

WARNING

Never unhitch without using the Tongue Jack. The Tongue is very heavy. Attempting to lift the Tongue without using the Tongue Jack could cause strains or other injury. Allowing the tongue to fall suddenly and unexpectedly could result in crushing injury. Use the Tongue Jack for lifting the Implement only. Overloading the Tongue Jack can cause failure with possible serious bodily injury or even death. (STI-04) str

DANGER

Always shut the Tractor completely down, place the transmission in park, and set the parking brake before you or anyone else attempts to connect or disconnect the Implement and Tractor hitches. (S3PT-15) str

1. Park on a level solid surface.
2. Remove all stroke control spacers from hydraulic cylinder and place on storage rack. Lower disc harrow until wheels are resting on the ground.
3. Place tractor gear selector in park, set the brake, shut tractor engine off, and remove switch key, Move cylinder lift lever back and forth to release hydraulic line pressure.
4. Rotate parking jack on the tongue down and install detent pin to lock parking jack in place. Set jack to desired height to maintain proper hook-up height.
5. Unhook hydraulic hoses from tractor and store hose ends on hydraulic hose loop.
6. Un-Bolt hitch from tractor. Once tractor is clear of hitch, reinstall bolt, washers, and nuts to the disc harrow clevis hitch for safe keeping.

OPERATION

13. IMPLEMENT STORAGE

Properly preparing and storing the cultivator at the end of the season is critical to maintaining its appearance and to help ensure years of dependable service. The following are suggested storage procedures:

- Thoroughly clean all debris off the unit to prevent damage from rotting grass and standing water.
- Lubricate all grease points as detailed in the maintenance section.
- Tighten all bolts and pins to the recommended torque.
- Check the unit for worn and damaged parts. Perform repairs and make replacements immediately so that the unit will be ready for use at the start of the next season.
- Store the unit in a clean, dry place with the implement resting securely on blocks or at ground level.
- Use spray touch-up enamel where necessary to prevent rust and maintain the appearance of the unit.



Never allow children or other persons to ride on the Tractor or Implement. Falling off can result in death or serious injury. (SG-10)str



Do not use your hands or feet to clean the disc gangs. The discs are sharp and serious injuries could result from inadvertent contact with the discs. Never attempt to stand on the discs, tires, or frame members of the implement. (STL-11) str

14. TRANSPORTING THE TRACTOR AND IMPLEMENT

Inherent hazards of operating the tractor and implement and the possibility of accidents are not left behind when you finish working in an area. Therefore, the operator must employ good judgment and safe operation practices when transporting the tractor and implement between locations. By using good judgment and following safe transport procedures, the possibility of accidents while moving between locations can be substantially minimized. OPS-U- 0017str



Never allow children or other persons to ride on the Tractor or Implement. Falling off can result in death or serious injury. (SG-10)str



14.1 Transporting on Public Roadways

Extreme caution should be used when transporting the tractor and implement on public roadways. The tractor must be equipped with all required safety warning features including a SMV emblem and flashing warning lights to alert drivers of the tractor's presence. Remember that roadways are primarily designed for automotive drivers and most drivers will not be looking out for you, therefore, you must look out for them. Check your side view mirrors frequently and remember that vehicles will approach quickly because of the tractor's slower speed. Be extremely cautious when the piece of equipment that you are towing is wider than the tractor tire width and/or extends beyond your lane of the road.

Make sure that a proper size safety tow chain is secured between the tractor and implement before entering a public road. OPS-U- 0019 str

OPERATION

WARNING

Make certain that the “Slow Moving Vehicle” (SMV) sign is installed in such a way as to be clearly visible and legible. When transporting the Equipment use the Tractor flashing warning lights and follow all local traffic regulations. (SG-6)str

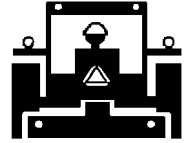

The SMV (Slow-Moving Vehicle) emblem is universal symbol used to alert drivers of the presence of equipment traveling on roadways at a slow speed. SMV signs are a triangular bright orange with reflective red trim for both easy day and night visibility. Make sure the SMV sign is clean and visible from the rear of the unit before transporting the tractor and implement on a public roadway. Replace the SMV emblem if faded, damaged, or no longer reflective. OPS-U- 0020str



Make sure that all tractor flashing warning lights, headlights, and brake/tail lights are functioning properly before proceeding onto public roads. While newer model tractors have plenty of lighting to provide warning signals and operating lighting, most older models are only equipped with operating lights. Consult an authorized tractor dealer for lighting kits and modifications available to upgrade the lighting on older tractor models. OPS-U- 0021str



When operating on public roads, have consideration for other road users. Pull to the side of the road occasionally to allow all following traffic to pass. Do not exceed the legal speed limit set in your country for agricultural tractors. Always stay alert when transporting the tractor and implement on public roads. Use caution and reduce speed if other vehicles or pedestrians are in the area. OPS-T-0013 str

OPERATION

Reduce speed before turning or applying the brakes. Ensure that both brake pedals are locked together when operating on public roads. *OPS-U-0023 str*



14.2 Hauling the Tractor and Implement

Before transporting a loaded tractor and implement, measure the height and width dimensions and gross weight of the complete loaded unit. Ensure that the load will be in compliance with the legal limits set for the areas that will be traveled through. OPS-U- 0024str



Use adequately sized and rated trailers and equipment to transport the tractor and implement. Consult an authorized dealer to determine the proper equipment required. Using adequately sized chains, heavy duty straps, cables and/or binders, securely tie down both the front and rear of the tractor utilizing the proper tie down locations as specified by the tractor manufacturer. *OPS-U-0025 str*



OPERATION

Arrange the chains so that when tightened, the chains are pulling downward and against themselves. Carefully tighten the securing chains or other fasteners using boomers or binders to apply maximum tension. Use extreme care when attaching and removing the securing devices as the extreme tension involved when released has the potential to inflict serious injury.



While hauling the tractor and implement, make occasional stops to check that the tractor and implement have not moved or shifted and that the securing chains have maintained tension. If during transport a hard braking, sharp turning, or swerving action was performed, stop at the next safe location to inspect the security of the load. OPS-U-0026str

OPERATION

OPERATION

15. TROUBLESHOOTING GUIDE

Problem	Possible Cause	Remedy
Disc Harrow Makes a High Center Ridge	Disc Blades are not moving enough soil to the center.	Tilt Disc Harrow up at the rear by turning spring adjuster counter-clockwise. See "Front to Rear Leveling".
		Set Tractor drawbar in its lowest possible position by flipping the offset drawbar over.
		Decrease tractor speed.
		Increase spacing between disc gangs by moving all gang hangers on both sides away from the center by equal amounts.
Disc Harrow Cuts a Furrow Soil to the Center	Disc Blades are not moving enough	Tilt Disc Harrow down at the rear, turning spring adjuster clockwise. Set tractor drawbar in its highest possible position. This can be done by flipping an offset drawbar over.
		Increase tractor speed.
		Reduce spacing between rear disc hangers on both sides toward the center by equal amounts.
Disc Harrow Makes Ridges on the Outside Cuts and Furrows Just Inside the Ridges	Too much soil is thrown out of the disc gangs.	Check front to rear disc leveling.
		Raise front disc gangs with threaded rod by turning it 2 or 3 revolutions clockwise.
		Reduce front disc gang angle by one position.
		Set tractor drawbar in its lowest possible position by flipping the offset drawbar over.
		Add disc furrow fillers to the rear disc gangs.
Disc Harrow Makes a Furrow on the Outside Cuts and a Ridge Just Inside the Furrow	Rear disc gangs are set too wide and pick up soil beyond where the front gangs throw it out.	Reduce spacing between rear disc gangs by moving all rear gang hangers in toward the center equal amounts.
		Raise front disc gangs by turning spring adjuster clockwise.
		Furrow fillers on the end of the rear disc gangs may be too large.

OPERATION

OPERATION

Problem	Possible Cause	Remedy
Disc Harrow Does Not Pull Straight and/or Shifts	Front disc gangs run deeper than the rear disc gangs.	Tilt Disc Harrow down at the rear by turning spring adjuster clockwise.
	Front disc gangs are not at the same angle.	Set front disc gangs at the same angle,
	Rear disc gangs are not at the same angle.	Set rear disc gangs at the same angle,
	Spring compressed length not set to the correct length.	Set spring compressed length to 12-1/2"
Disc Harrow Leaves a Depression in the Worked Soil Behind Tractor Wheels	Tire slippage, heavy tractor, soft soil conditions.	Add duals, increase tractor speed, increase gang angle.
		Tilt Disc Harrow down at the rear by turning spring adjuster clockwise.
Disc Harrow Won't Settle Down and Operate Smoothly	Disc gang angles are set too high.	Set disc angles at the smallest angle required to do the job.
		Make sure that front disc gangs are set 3 degrees more than the rear disc gangs.
Disc Harrow Does Not Penetrate the Soil Properly	Disc gangs are not set at enough angle,	Increase disc gang angles. Make sure the front disc angles are set 3 degrees more than the rear disc gangs.
	Tires are not raised off of ground.	Raise disc harrow tires off the ground by fully retracting hydraulic lift cylinder.
	Not enough weight with tires raised off of the ground.	Fill disc harrow tires with water or calcium chloride.
		Do not add weight such as tractor weights to the disc harrow frame.
Outside Front Disc Blades and/or Gang Axle is Bending or Breaking	Making sharp turns and crossing ditches with Disc Harrow in the ground.	Raise disc harrow out of the ground when making sharp turns and crossing ditches.
	Gang axles becoming loose.	Keep disc gang axle nuts tight.

OPERATION

Problem	Possible Cause	Remedy
Disc Gang Axles Keep Coming Loose or are Bending	Disc components are not sliding on axle.	Check fit-up of all disc components. Makes sure all components are tight against one another. Especially check to make sure end washers and disc blade are correct.
	Foreign objects become clamped between disc components.	Completely disassemble disc gang components and clean thoroughly before re-assembly. Check spacers for uneven edges that will not allow a tight seal between disc blade and spacer.
	Solid objects in the soil such as rocks and stumps.	Remove solid obstructions, raise disc up above solid objects, or go around. Travel 3 MPH or slower over smaller obstructions.
Bearing Problems	Bent gang axle causing bearing to wobble.	Replace gang axle and damaged bearings.
	Foreign objects and/or dirt caught between spacer and disc blades causing bearing to wobble.	Completely disassemble disc gang components and clean thoroughly before re-assembly. Check spacers for uneven edges that will not allow a tight seal between disc blade and spacer.
	Abrasive material such as wire rubbing against the bearing and destroying the seals.	Remove abrasive material right away. Replace damaged bearings.
	Contaminated bearings caused by cleaning the grease fittings before adding grease to the bearings.	Always clean grease fittings before pumping grease into the bearings. Replace damaged bearings.
	Pumping grease into the bearing too fast in cold weather will pop off bearing seals.	Pump grease into the bearings slowly especially in cold weather. Replace all damaged bearings.

MAINTENANCE SECTION

Maintenance Section 5-1

MAINTENANCE

LUBRICATION

Make sure all of the lubrication points are greased before every use to prevent damage to components.

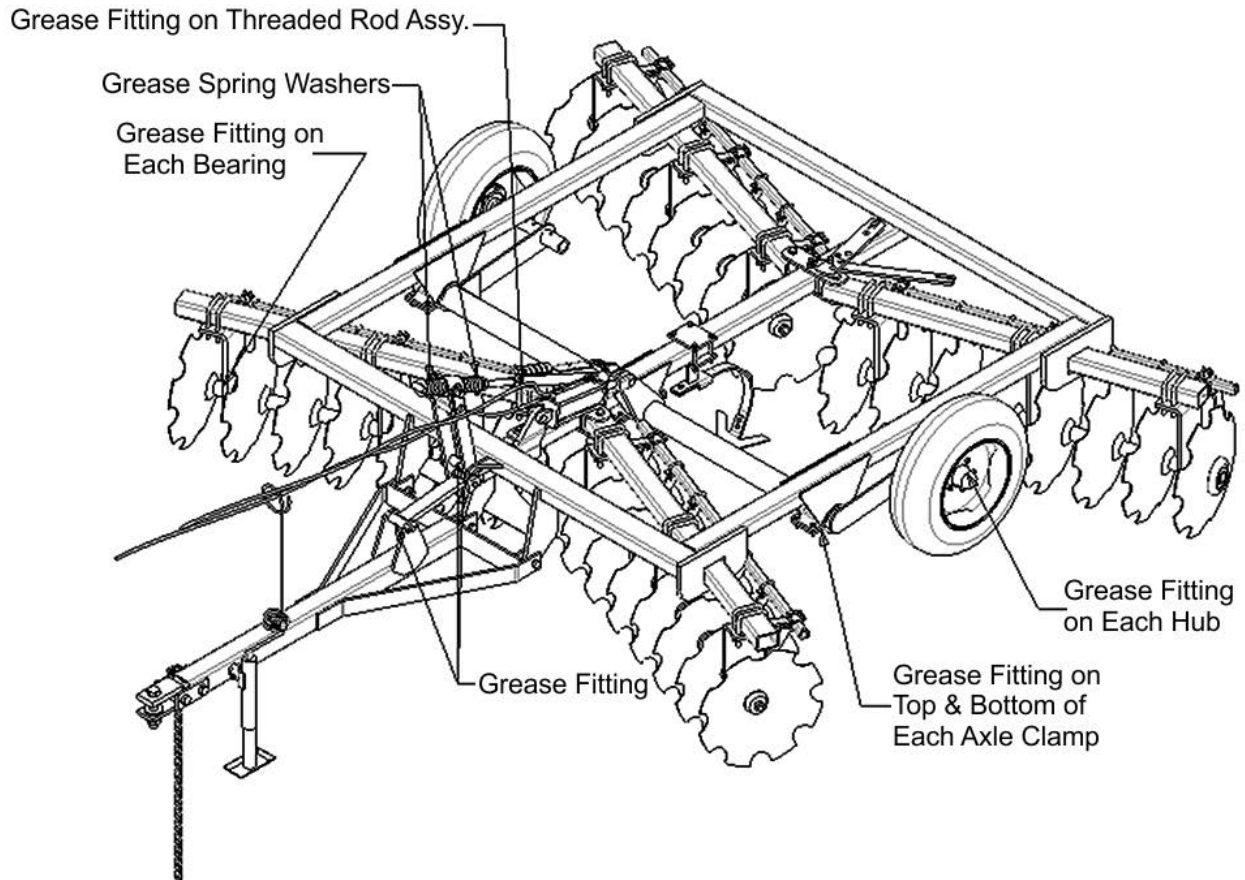

MAINTENANCE

PROPER TORQUE FOR FASTENERS

The chart lists the correct tightening torque for fasteners. When bolts are to be tightened or replaced, refer to this chart to determine the grade of bolts and the proper torque except when specific torque values are assigned in manual text.

Recommended Torque in Foot Pounds Unless Otherwise Stated in the Manual*

NOTE: These values apply to fasteners as received from supplier, dry or when lubricated with normal engine oil. They do not apply if special graphited or molydisulphide greases or other extreme pressure lubricants are used. This applies to both UNF fine and UNC coarse threads.

MAINTENANCE

MAINTENANCE

TORQUE SPECIFICATIONS - DRY TORQUE

Proper torque for American fasteners.
Recommended Torque in Foot Pounds (Newton Meters).*

AMERICAN Bolt Head Markings

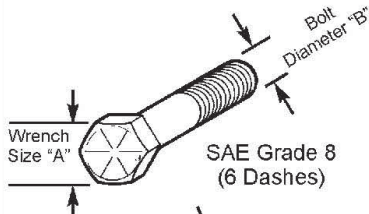

WRENCH SIZE (IN.) "A"	BOLT DIAMETER (IN.) "B" AND THREAD SIZE	SAE GRADE 2	SAE GRADE 5	SAE GRADE 8
7/16	1/4 - 20 UNC	6 (7)	8 (11)	12 (16)
7/16	1/4 - 28 UNF	6 (8)	10 (13)	14 (18)
1/2	5/16 - 18 UNC	11 (15)	17 (23)	25 (33)
1/2	5/16 - 24 UNF	13 (17)	19 (26)	27 (37)
9/16	3/8 - 16 UNC	20 (27)	31 (42)	44 (60)
9/16	3/8 - 24 UNF	23 (31)	35 (47)	49 (66)
5/8	7/16 - 14 UNC	32 (43)	49 (66)	70 (95)
5/8	7/16 - 20 UNF	36 (49)	55 (75)	78 (106)
3/4	1/2 - 13 UNC	49 (66)	76 (103)	106 (144)
3/4	1/2 - 20 UNF	55 (75)	85 (115)	120 (163)
7/8	9/16 - 12 UNC	70 (95)	109 (148)	153 (207)
7/8	9/16 - 18 UNF	79 (107)	122 (165)	172 (233)
15/16	5/8 - 11 UNC	97 (131)	150 (203)	212 (287)
15/16	5/8 - 18 UNF	110 (149)	170 (230)	240 (325)
1-1/8	3/4 - 10 UNC	144 (195)	266 (360)	376 (509)
1-1/8	3/4 - 16 UNF	192 (260)	297 (402)	420 (569)
1-5/16	7/8 - 9 UNC	166 (225)	430 (583)	606 (821)
1-5/16	7/8 - 14 UNF	184 (249)	474 (642)	668 (905)
1-1/2	1 - 8 UNC	250 (339)	644 (873)	909 (1232)
1-1/2	1 - 12 UNF	274 (371)	705 (955)	995 (1348)
1-1/2	1 - 14 UNF	280 (379)	721 (977)	1019 (1381)
1-11/16	1-1/8 - 7 UNC	354 (480)	795 (1077)	1288(1745)
1-11/16	1-1/8 - 12 UNF	397 (538)	890 (1206)	1444 (1957)
1-7/8	1-1/4 - 7 UNC	500 (678)	1120 (1518)	1817 (2462)
1-7/8	1-1/4 - 12 UNF	553 (749)	1241 (1682)	2013 (2728)
2-1/16	1-3/8 - 6 UNC	655 (887)	1470 (1992)	2382 (3228)
2-1/16	1-3/8 - 12 UNF	746 (1011)	1672 (2266)	2712 (3675)
2-1/4	1-1/2 - 6 UNC	870 (1179)	1950 (2642)	3161 (4283)
2-1/4	1-1/2 - 12 UNF	979 (1327)	2194 (2973)	3557 (4820)

METRIC

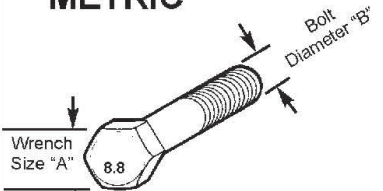

Numbers appearing on bolt heads indicate ASTM class.

*Use 75% of the specified torque value for plated fasteners. Use 85% of the specified torque values for lubricated fasteners.

Proper torque for Metric fasteners.
Recommended torque in Foot Pounds (Newton Meters).*

WRENCH SIZE (mm) "A"	BOLT DIA. (mm) "B"	ASTM 4.6	ASTM 8.8	ASTM 9.8	ASTM 10.9
8	5	1.8 (2.4)		5.1 (6.9)	6.5 (8.8)
10	6	3 (4)		8.7 (12)	11.1 (15)
13	8	7.3 (10)		21.1 (29)	27 (37)
16	10	14.5 (20)		42 (57)	53 (72)
18	12	25 (34)	74 (100)	73 (99)	93 (126)
21	14	40 (54)	118 (160)	116 (157)	148 (201)
24	16	62 (84)	167 (226)	181 (245)	230 (312)
30	20	122 (165)	325 (440)		449 (608)
33	22		443 (600)		611 (828)
36	24	211 (286)	563 (763)		778 (1054)
41	27		821 (1112)		1138 (1542)
46	30	418 (566)	1119 (1516)		1547 (2096)

Mnt-B-0005



TO THE OWNER/OPERATOR/DEALER

To keep your implement running efficiently and safely, read your manual thoroughly and follow these directions and the Safety Messages in this Manual. The Table of Contents clearly identifies each section where you can easily find the information you need.

The OCCUPATIONAL SAFETY AND HEALTH ACT (1928.51 Subpart C) makes these minimum safety requirements of tractor operators:

REQUIRED OF THE OWNER:

1. Provide a Roll-Over-Protective Structure that meets the requirements of this Standard; and
2. Provide Seat belts that meet the requirements of this paragraph of this Standard and SAE J4C; and
3. Ensure that each employee uses such Seat belt while the tractor is moving; and
4. Ensure that each employee tightens the Seat belt sufficiently to confine the employee to the protecte-darea provided by the ROPS

REQUIRED OF THE OPERATOR:

1. Securely fasten seat belt if the tractor has a ROPS.
2. Where possible, avoid operating the tractor near ditches, embankments, and holes.
3. Reduce speed when turning, crossing slopes, and on rough, slick, or muddy surfaces.
4. Stay off slopes too steep for safe operation.
5. Watch where you are going - especially at row ends, on roads, and around trees.
6. Do not permit others to ride.
7. Operate the tractor smoothly - no jerky turns, starts, or stops.
8. Hitch only to the drawbar and hitch points recommended by the tractor manufacturer.
9. When the tractor is stopped, set brakes securely and use park lock, if available.

X Keep children away from danger all day, every day...

X Equip tractors with rollover protection (ROPS) and keep all machinery guards in place...

X Please work, drive, play and live each day with care and concern for your safety and that of your family and fellow citizens.



BUSH HOG[®]

**DHP8/DHP10/DHP12
DISC HARROW**