

BUSH HOG®

MODELS: 5110/15110 5115/15115

FLEX WING ROTARY CUTTER

Revised 02/24

PARTS MANUAL SECTION 135



An Operator's Manual was shipped with the equipment. The Operator's Manual is an integral part of the safe operation of this machine and must be maintained with the unit at all times. **READ, UNDERSTAND, and FOLLOW** the Safety and Operation Instructions contained in this manual before operating the equipment. If the Operator's Manual is not with the equipment, contact your dealer or Bush Hog to obtain a copy before operating the equipment.

Safety Video

Important Operating and Safety Instructions are found in the Mower Safety Video that can be instantly accessed on the Internet at: www.algqr.com/bve



www.algqr.com/bve

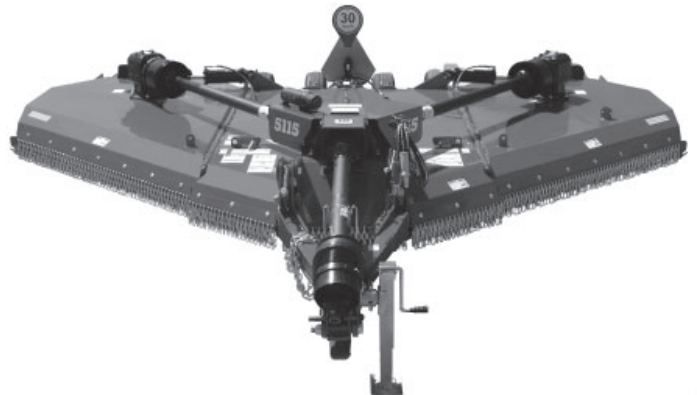
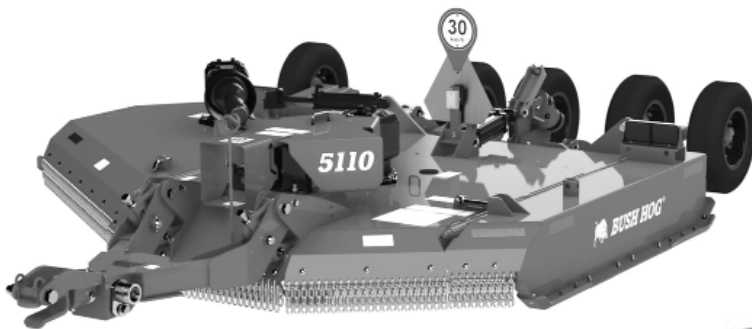

BUSH HOG®

2501 Griffin Ave.
Selma, AL. 36703
Parts Ordering 800-304-2836
www.bushhog.com

ATENCIÓN!

LEA EL INSTRUCTIVO

Si No Lee Ingles, Pida Ayuda a Alguien
Que Si Lo Lea Para Que le Traduzca las
Medidas de Seguridad.



A MEMBER OF THE
ALAMO GROUP
ALWAYS ON THE CUTTING EDGE®

© 2024 Alamo Group Inc.

PARTS ORDERING GUIDE

The following instructions are offered to help eliminate needless delay and error in processing purchase orders for the equipment in this section.

1. The Parts Section is prepared in logical sequence and grouping of parts that belong to the basic machine featured in this manual. Part Numbers and Descriptions are given to help locate the parts and quantities required.
2. The Purchase Order must include the name and address of the person or organization ordering the parts, who should be charged, and if possible, the serial number of the machine for which the parts are ordered.
3. The Purchase Order must clearly list the quantity of each part, the complete and correct part number (be sure to include all periods), and the basic name of the part.
4. The Manufacturer reserves the right to substitute parts where applicable.
5. Some parts are unlisted items which are special production items not normally stocked and are subject to special handling. Request a quotation for such parts before sending a Purchase Order.
6. The Manufacturer reserves the right to change prices without prior notice.



For maximum safety and to guarantee optimum product reliability, always use genuine BUSH HOG Parts. The use of inferior replacement parts may cause premature or catastrophic failure which could result in serious injury or death. Direct any questions regarding parts to:

BUSH HOG
2501 Griffin Ave.
Selma, AL. 36703
www.bushhog.com
Contact Us
800-304-2836



BUSH HOG®

To the Owner/Operator/Dealer





All implements with moving parts are potentially hazardous. There is no substitute for a cautious, safe-minded operator who recognizes the potential hazards and follows reasonable safety practices. The manufacturer has designed this implement to be used with all its safety equipment properly attached to minimize the chance of accidents.

BEFORE YOU START! Read the safety messages on the implement and shown in your manual. Observe the rules of safety and common sense!



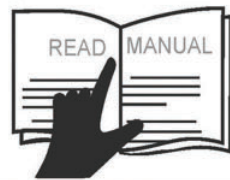



DANGER

FAILING TO FOLLOW SAFETY MESSAGES AND OPERATING INSTRUCTION CAN CAUSE SERIOUS BODILY INJURY OR EVEN DEATH TO OPERATOR AND OTHERS IN THE AREA.

<p>1.</p> 	<p>2. NO RIDERS. NO CHILDREN OPERATORS.</p> 	<p>3. USE SAFETY SHOES, HARD HAT, SAFETY GLASSES, SEAT BELTS, ROPS & OPS.</p> 	<p>4. BLOCK UP SECURELY BEFORE WORKING UNDER.</p> 
---	---	--	---

1. Study and understand Operator's Manuals, Safety Decals, and Instructional Decals for tractor and implement to prevent misuse, abuse, and accidents. Practice before operating in a confined area or near passersby.
 - Learn how to stop engine suddenly in an emergency. Be alert for passersby and especially children.
2. Allow no children on or near folding mower or tractor. Allow no riders on tractor or implement. Falling off may cause serious injury or death from being run over by tractor or mower or contact with rotating blades.
3. Operate only with tractor having Roll-Over Protective Structure (ROPS) and with seat belt securely fastened to prevent injury and possible death from falling off or tractor overturn.
 - Personal Protective Equipment such as Hard Hat, Safety Glasses, Safety Shoes, & Ear Plugs are recommended.
4. Block up or support raised machine and all lifted components securely before putting hands or feet under or working underneath any lifted component to prevent crushing injury or death from sudden dropping or inadvertent operation of controls. Make certain area is clear before lowering or folding.
5. Before transporting, put Lift Lever in detent or full-lift position. Install Transport Safety Devices securely on folding mowers. Put Booms securely in Transport Rest.
 - Folding and Boom Mowers have raised center of gravity. Slow down when turning and on hillsides.
6. Make certain that SMV sign, warning lights, and reflectors are clearly visible. Follow local traffic codes.
7. Never operate with Cutting Head or Folding Section raised if passersby, bystanders, or traffic are in the area to reduce possibility of injury or death from objects thrown by Blades under Guards or mower structure.
8. Before dismounting, secure implement in transport position or lower to ground.
 - Put tractor in park position or set brake, disengage PTO, stop engine, remove key, and wait until noise of rotation has ceased to prevent crushing by entanglement in rotating parts which could cause injury or death.
 - Never mount or dismount a moving vehicle. Crushing from runover may cause serious injury or death.

<p>5. TRANSPORT SAFELY, LOCK UP.</p> 	<p>6. USE SMV, LIGHTS, & REFLECTORS.</p> 	<p>7. DO NOT OPERATE WITH CUTTER OR WING RAISED</p> 	<p>8. DO NOT MOUNT OR DISMOUNT WHILE MOVING.</p> 
--	--	--	--

02967827



WARNING

Cancer and Reproductive Harm
www.P65Warnings.ca.gov

WARRANTY INFORMATION:

Read and understand the complete Warranty Statement found in this Manual. Fill out the Warranty Registration Form in full and return it to within 30 Days. Make certain the Serial Number of the Machine is recorded on the Warranty Card and on the Warranty Form that you retain.

WARRANTY

LIMITED WARRANTY

Bush Hog warrants to the original purchaser of any new Bush Hog equipment, purchased from an authorized Bush Hog dealer, that the equipment be free from defects in material and workmanship for a period of three (3) years from date of retail sale. The obligation of Bush Hog to the purchaser under this warranty is limited to the repair or replacement of defective parts.

Replacement or repair parts installed in the equipment covered by this limited warranty are warranted for ninety (90) days from the date of purchase of such part or to the expiration of the applicable new equipment warranty period, whichever occurs later. Warranted parts shall be provided at no cost to the user at an authorized Bush Hog dealer during regular working hours. Bush Hog reserves the right to inspect any equipment or parts which are claimed to have been defective in material or workmanship.

In addition to the standard Limited Warranty shown above, Bush Hog also provides:

A TEN-YEAR (120 months) GEARBOX LIMITED WARRANTY* (6 Years Full Coverage; Parts Only for Years 7 through 10) provided they have been properly maintained† and have not been subjected to abuse or mis-use except as limited below.

*WARRANTY LIMITATIONS - GEARBOX

- A. Gearbox warranty extends to the original purchaser of a Bush Hog Rotary Cutter Only.
- B. Warranty claimant must provide proper product registration and original receipt for purchase.
- C. Bush Hog reserves the right to warrant Gearboxes and components at our discretion based on photographic or video evidence of product failure.
- D. If Bush Hog deems a Gearbox failed due to defects in materials or workmanship, users' Gearboxes may be rebuilt by Bush Hog or replaced by new or rebuilt Gearboxes at the option of Bush Hog.

A ONE-YEAR (12 months) LIMITED WARRANTY** on the DRIVELINE components provided they have been properly maintained† and have not been subjected to abuse or mis-use.

* **WARRANTY LIMITATIONS - DRIVELINE

- A. A ONE-YEAR (12 months) DRIVELINE LIMITED WARRANTY applies to SHIELDS except where evidence of wear from contact with other parts on the shield voids this warranty.
- B. Shield Bearings are wearing parts and are not warrantable.
- C. Slip-Clutch Plates are wearing parts and are not warrantable. Evidence of "burning up" Slip-Clutch Plates due to improper adjustment will void warranty on Slip-Clutch Parts.

† NOTE - "properly maintained" specifically includes, but is not limited to:

- A) Running Gearboxes with the proper amount of the correct lubricant.
- B) Adjusting Slip-Clutches correctly to provide proper protection for Driveline and Gearbox components.
- C) Proper lubrication of all DRIVELINE components as specified.
- D) Maintaining proper bearing preload on all Gearbox shafts.

WARRANTY

DISCLAIMER OF IMPLIED WARRANTIES & CONSEQUENTIAL DAMAGES

Bush Hog's obligation under this limited warranty, to the extent allowed by law, is in lieu of all warranties, implied or expressed, INCLUDING IMPLIED WARRANTIES OF MERCHANTABILITY AND FITNESS FOR A PARTICULAR PURPOSE and any liability for incidental and consequential damages with respect to the sale or use of the items warranted. Such incidental and consequential damages shall include but not be limited to: transportation charges other than normal freight charges; cost of installation other than cost approved by Bush Hog; duty; taxes; charges for normal service or adjustment; loss of crops or any other loss of income; rental of substitute equipment, expenses due to loss, damage, detention or delay in the delivery of equipment or parts resulting from acts beyond the control of Bush Hog.

THIS LIMITED WARRANTY SHALL NOT APPLY:

1. To vendor items which carry their own warranties.
2. If the unit has been subjected to misapplication, abuse, misuse, negligence, fire or other accident.
3. If parts not made or supplied by Bush Hog have been used in connection with the unit, if, in the sole judgment of Bush Hog such use affects its performance, stability or reliability.
4. If the unit has been altered or repaired outside of an authorized Bush Hog dealership in a manner which, in the sole judgment of Bush Hog, affects its performance, stability or reliability.
5. To normal maintenance service and normal replacement items such as gearbox lubricant, hydraulic fluid, worn blades, or to normal deterioration of such things as belts and exterior finish due to use or exposure.
6. To expendable or wear items such as teeth, chains, sprockets, belts, springs and any other items that in the company's sole judgment is a wear item.

IN ORDER FOR WARRANTIES TO BE PROCESSED, PRODUCT WARRANTY REGISTRATION MUST BE FILED WITH BUSH HOG THROUGH THE SELLING DEALER.

Retain original purchase receipt and record the model number, serial number and date of purchase. This information will be helpful to your dealer if parts or services are required.

MODEL NUMBER _____

SERIAL NUMBER _____

DATE OF PURCHASE _____

NO EMPLOYEE OR REPRESENTATIVE OF BUSH HOG IS AUTHORIZED TO CHANGE THIS LIMITED WARRANTY IN ANY WAY OR GRANT ANY OTHER WARRANTY UNLESS SUCH CHANGE IS MADE IN WRITING AND SIGNED BY BUSH HOG'S SERVICE MANAGER, 2501 GRIFFIN AVE., SELMA, AL. 36703

TABLE OF CONTENTS

MODELS: 5110, 5115, 15110 & 15115

FLEX WING ROTARY CUTTER

ALPHABETICAL INDEX

CONTENTS	PAGE
Axles, Center & Wings.....	135-5-4, 135-5-5
Axle Arms Single & Dual Spindles.....	135-5-6
Axle Arms, Tandem Center & Wings.....	135-5-7
Base Assembly, Center.....	135-1-1, 135-1-2
Base Assembly, RH Wing & LH Wing.....	135-1-3, 135-1-4
Blades & Blade Holders.....	See Base Assemblies
Chain, Safety Tow.....	135-5-1
Chains, Double Row, Front & Rear.....	135-2-1
Cylinder, Hydraulics.....	135-6-3
Decal Kit.....	135-7-1
Driveline Holder Assembly.....	135-5-2
Driveshafts.....	135-4-1 thru 135-4-5
Gauge Wheel Kit.....	135-5-10
Gearbox, Transfer 540 RPM.....	135-3-1
Gearbox, Transfer 1000 RPM.....	135-3-2
Gearbox, Center & LH Wing 540 RPM.....	135-3-3
Gearbox, RH Wing 540 RPM.....	135-3-4
Gearbox, Center 1000 RPM.....	135-3-3
Gearbox, LH Wing 1000 RPM.....	135-3-5
Gearbox, RH Wing 1000 RPM.....	135-3-6
Hitch Assemblies.....	135-5-3
Hydraulic Fittings To Tractor Remotes.....	135-6-1, 135-6-2
Jackstand.....	135-5-1
LED Light Kit (Rear Lights Only).....	135-2-4, 135-2-5
Leveling Rod Assembly.....	135-5-1
Shield Assembly, Center.....	135-2-2
Shielding, Wing Driveline.....	135-2-3
SMV Sign	135-1-6
Tire, Solid, Segmented, Airplane & Foam Filled.....	135-5-8, 135-5-9
Tongue Assembly.....	135-5-1
Weight Box Assembly (5110/15110).....	135-1-5

CENTER DECK ASSEMBLY

5115RR1, 5115RR1 (540 RPM Models)
15110RR1, 15115RR1 (1000 RPM Models)

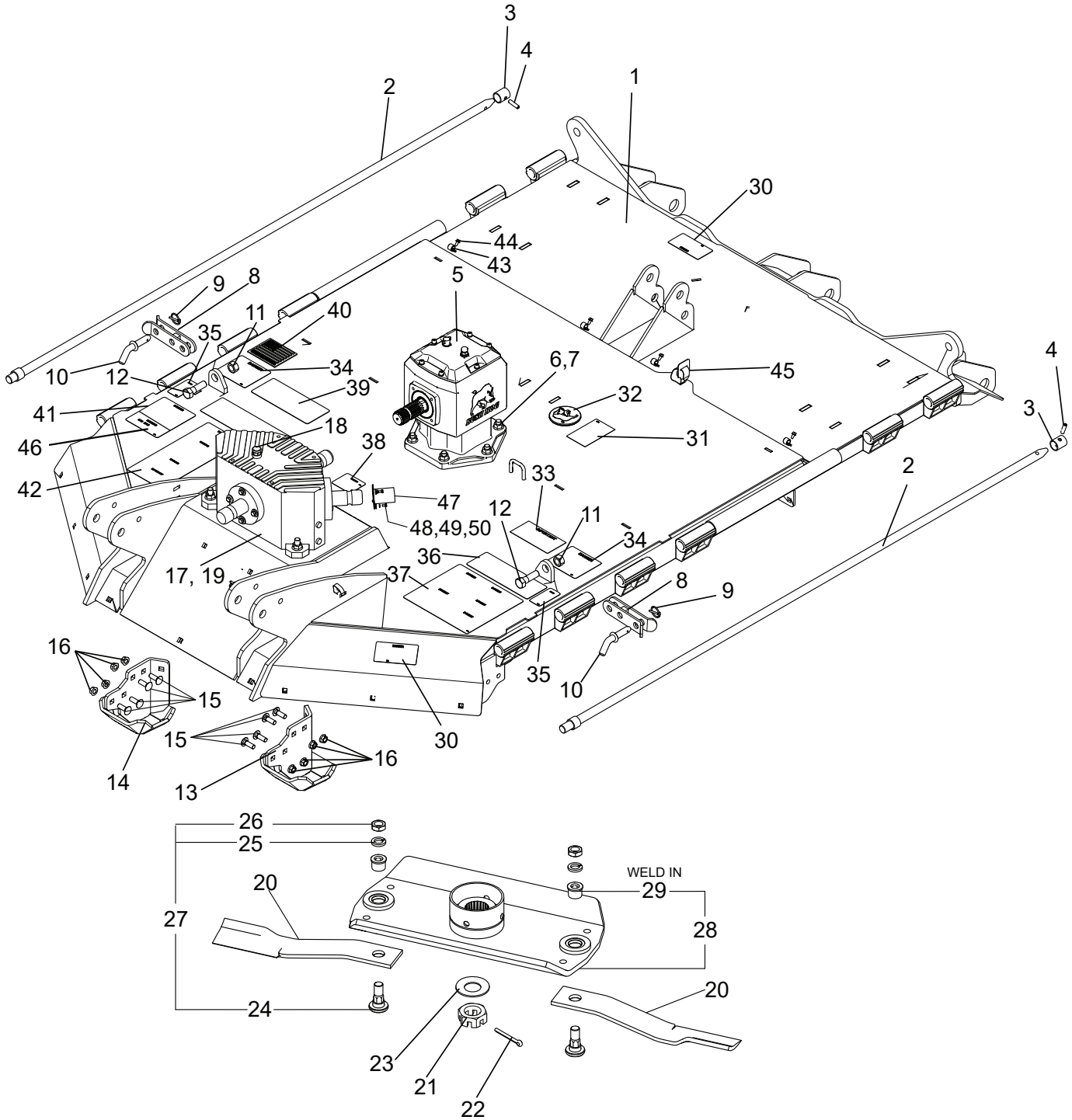

CENTER DECK ASSEMBLY

5110RR1, 5115RR1 (540 RPM Models)

15110RR1, 15115RR1 (1000 RPM Models)

Item No.	Part No.	Description	Qty.	Item No.	Part No.	Description	Qty.
1	50083839	Center Deck w/ Rings &Decal	1	27	50076475	Blade Bolt Kit	2
2	50083146	Hinge Pin Weldment	2	28	50082270	Blade Pan Weldment, 27.50"	1
3	91900BH	Lock Collar	2	29	50076706	Hex Blade Bolt Bushing (Weld-In)	2
4	19529	Spirol Pin 3/8" x 1-1/2"	2	30	D614	Decal, Danger - Thrown Object	2
5	50071561BH	Gearbox (540 RPM)	1	31	D551	Decal, Blade Rotation CCW	1
	50071563BH	Gearbox (1000 RPM)	1	32	50083384	Blade Bolt Access Cap	1
6	20414	Locknut, 5/8" Gr. C CP Fling	10	33	91443	Decal, Important	1
7	44262BH	HHCS 5/8" x 2-1/2" G8 ZP	10	34	D565	Decal, Danger	2
8	50084082	Wing Latch Weldment	2	35	D555	Decal, Danger	2
9	69391	Lynch Pin	2	36	D813	Decal, Danger	1
10	50076342	Pin	2	37	D549	Decal, Danger - Operation	1
11	20638	Locknut, 3/4" CP	2	38	D546	Decal, Danger	1
12	1162424	Capscrew, 3/4" x 2-1/2" G5	2	39	D559	Decal, Genuine BH Parts	1
13	50083668	LH Center Skid Weldment	2	40	50074259	Decal, Made in USA	1
14	50083669	RH Center Skid Weldment	2	41	D547	Decal, Danger (50 RPM)	1
15	5161614	Carriage Bolt, 1/2" x 1-1/2" Gr. 5	8	42	D553	Decal, Warning	1
16	44998BH	Locknut, 1/2" CNTR. Fling GR F CP	8	43	50083661	P-Clip 1/2"	4
17	71202	Transfer Gearbox (540 RPM)	1	44	45350BH	Hex Fling Hd, 4 Thrd Cut Type F 1/4" x 3/4" ZP	4
	50072724	Transfer Gearbox (1000 Rpm)	1	45	50083219	Hook & Loop Strap	2
18	80538	Valve Vent Plug	1	46	D548	Decal, Warning (1000 RPM)	1
19	50074090	Sight Window	1	47	50028363	Shaft Cover Weldment (5110/15110)	1
20	50080466	5" Blade, 22.25" Corner Uplift CCW	2				
21	50071363	Nut, Slotted Hex Jam 2"-12"	1	48	90560	M8x1.25x15 G8.8 ZP W. Patch (5110/15110)	4
22	50071364	Cotter Pin, 10MM x 100MM	1				
23	50071362	Spring Washer	1	49	44311BH	Lockwasher, M8 (5110/15110)	4
24	50076705	Hex Blade Bolt	1	50	44216	Flatwasher, M8 (5110/15110)	4
25	20322	Lockwasher, 1-1/8" CP	2				
26	252BH	Jam Nut, 1-1/8" NF G8 HT	2				

WING DECK ASSEMBLY

5110RR1, 5115RR1 (540 RPM Models)
15110RR1, 15115RR1 (1000 RPM Models)

This Part Listing applies to
RH & LH Wings

RH WING SHOWN

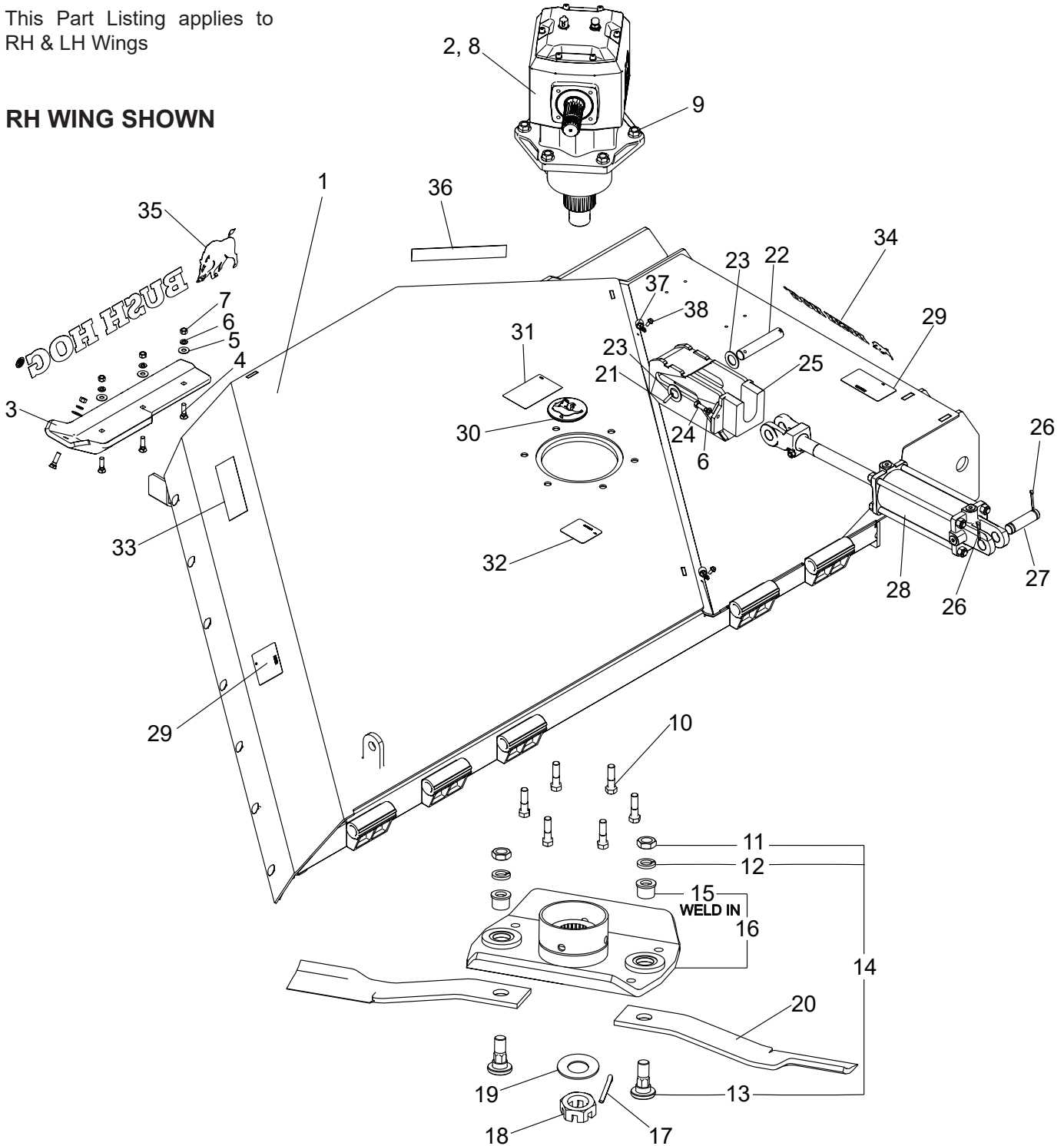

WING DECK ASSEMBLY

5110RR1, 5115RR1 (540 RPM Models)

15110RR1, 15115RR1 (1000 RPM Models)

Item No.	Part No.	Description	Qty.	Item No.	Part No.	Description	Qty.
1	50083840	RH Wing Deck w/Rings & Decals	1	18	50071363	Nut, Slotted Hex Jam, 2" - 12"	1
	50083841	LH Wing Deck w/Rings & Decals	1	19	50071362	Spring Washer	1
2	50071562BH	Gearbox, RH (540 RPM)	1	20	50080466	Blade, 22.25" Corner Uplift, CCW, RH	2
	50071561BH	Gearbox, LH (540 RPM)	1		50083110	Blade, 22.25" Corner Uplift, CW, LH	2
	50071565BH	Gearbox, RH (1000 RPM)	1	21	20167	Cotter Pin, 3/16" x 2" ZP	1
	50071564BH	Gearbox, LH (1000 RPM)	1	22	87294	Cylinder Pin	1
3	50083380	RH Cast skid	1	23	20376	Flatwasher, 1"	2
	50083381	LH Cast Skid	1	24	20034	Capscrew, 3/8" x 1"	2
4	44928BH	#3 Plow Bolt 3/8" x 1-1/2" G5 ZP	4	25	50031959	Push Over Assy.	1
5	15915BH	Flatwasher, 3/8" ZP	4	26	21020614	Cotter Pin, 3/16" x 1-1/2"	2
6	15812	Lockwasher, 3/8"	6	27	95425	Pin	1
7	8151200	Hex Nut, 3/8"	4	28	50081896	Wing Lift Cylinder	1
8	50074090	Sight Window, Gearbox	1	29	D614	Decal, Danger - Thrown Object	2
9	20414	Locknut, 5/8" Flanged	6	30	50083384	Blade Bolt Access Cap	1
10	44262BH	HHCS 5/8" x 2-1/2" G8 ZP	6	31	D551	Decal, Blade Rotation CCW, RH	1
11	252BH	Jam Nut, 1-1/8" NF G8 HT	2		D552	Decal, Blade Rotation, CW, LH	1
12	20322	Lockwasher, 1-1/8" CP	2	32	D546	Decal, Danger	1
13	50076705	Hex Blade Bolt	2	33	50031212	Reflector, Amber	1
14	50076475	Blade Bolt Kit	2	34	50065309	Decal, Bush Hog Logo	1
15	50076706	Hex Blade Bolt Bushing (Weld in)	2	35	50080370	Decal, Bush Hog Logo	1
16	50082275	15.5" Blade Pan Weldment	1	36	50031214	Reflector, Red	1
17	50071364	Cotter Pin, 10MM x 100MM	1	37	50083661	P-Clip, 1/2"	2
				38	45350BH	Hex Flng Hd, 4 Thrd Cut Type F 1/4" x 3/4" ZP	2
				39	50075045	Decal, Bush Hog (item not shown)	2

WEIGHT BOX ASSEMBLY 5110RR1 / 15110RR1

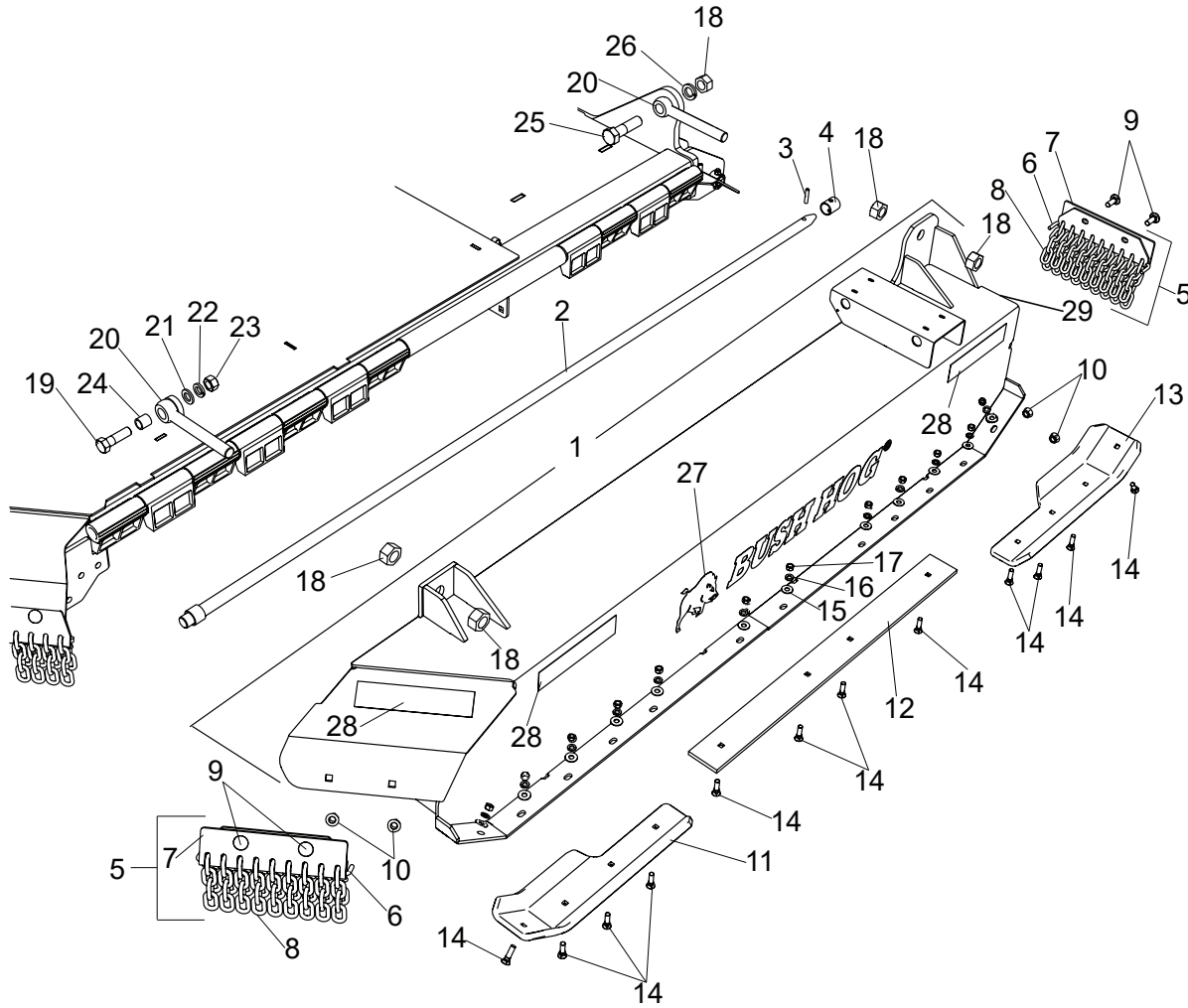

Item No.	Part No.	Description	Qty.	Item No.	Part No.	Description	Qty.
1	50083848	Weight Box w/Decals	1	16	15812	Lockwasher, 3/8" CP	12
2	50083146	Hinge Pin Weldment	4	17	8151200	Hex Nut, 3/8" CP	12
3	19529	Spirol Pin, 3/8" x 1-1/2"	4	18	19502	Hex Nut, 1 CP	5
4	91900BH	Lock Collar	4	19	1162424	Hex Hd. Cpssc, 3/4" x 2-1/2" G5 ZP	1
5	50083781	Chain Assy., Weight Box	2	20	87052	Rod Eye	2
6	50083782	Rod Chain	2	21	119	Flatwasher, 3/4" SAE	1
7	50083779	Chain, Bracket	2	22	146	Lockwasher, 3/4" ZP	1
8	50017212	Chain, 7 Link Plated	16	23	19517	Hex Nut, 3/4" CP	1
9	5161614	Carriage Bolt, 1/2" x 1-1/2" G5 ZP	4	24	50038099	Bushing	1
10	44998BH	Locknut, 1/2" Cntr. Flng Gr. F CP	4	25	19060	Hex Hd. Cpssc., 1" x 3-3/4" G5 ZP	1
11	50083381	LH Cast Skid	1	26	15821	Lockwasher, 1" CP	1
12	50083842	Skid	1	27	50080370	Decal, BH 4.52" x 29.70"	1
13	50083380	RH Cast Skid	1	28	50031212	Reflector, Amber	3
14	44928BH	#3 HD Plow Bolt 3/8" x 1-1/2" G5	12	29	50031214	Reflector, Red	1
15	15915BH	Flatwasher, 3/8" ZP	12				

SMV SIGN

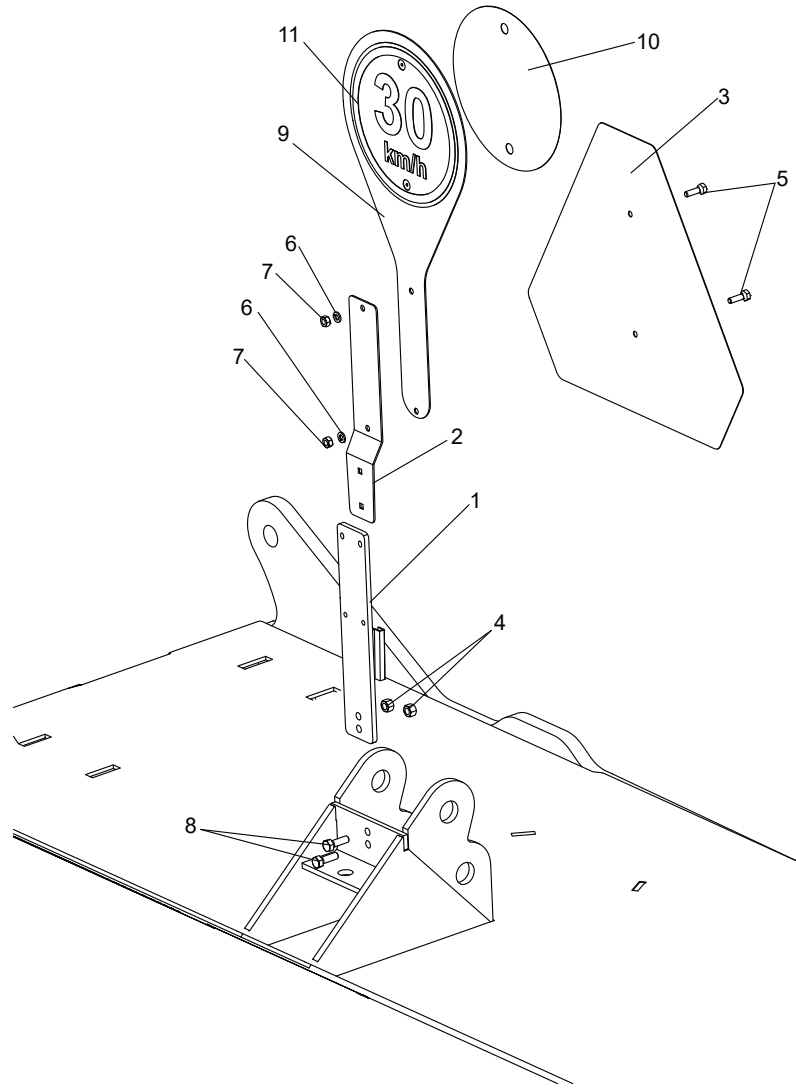

Item No.	Part No.	Description	Qty.
1	50074198	SMV Mount Weldment	1
2	2438621	SMV Spade Bracket	1
3	94359	SMV Sign	1
4	15602BH	Locknut, 5/16"	2
5	1160807	Capscrew, 1/4" x 7/8" Gr. 5	2
6	15905	Lockwasher, 1/4"	2
7	15531BH	Hex Nut, 1/4"	2
8	45011BH	Caspcrew, 5/16" x 1" Gr. 5	2
9	50082008	SIS Plate w/Decals	1
10	50082007	Decal, Speed (20 mile/h)	1
11	50082010	Decal, Speed ID (30 km/h)	1

FRONT & REAR CHAINS - DOUBLE ROW

5110RR1, 5115RR1 (540 RPM)

15110RR1, 15115RR1 (1000 RPM)

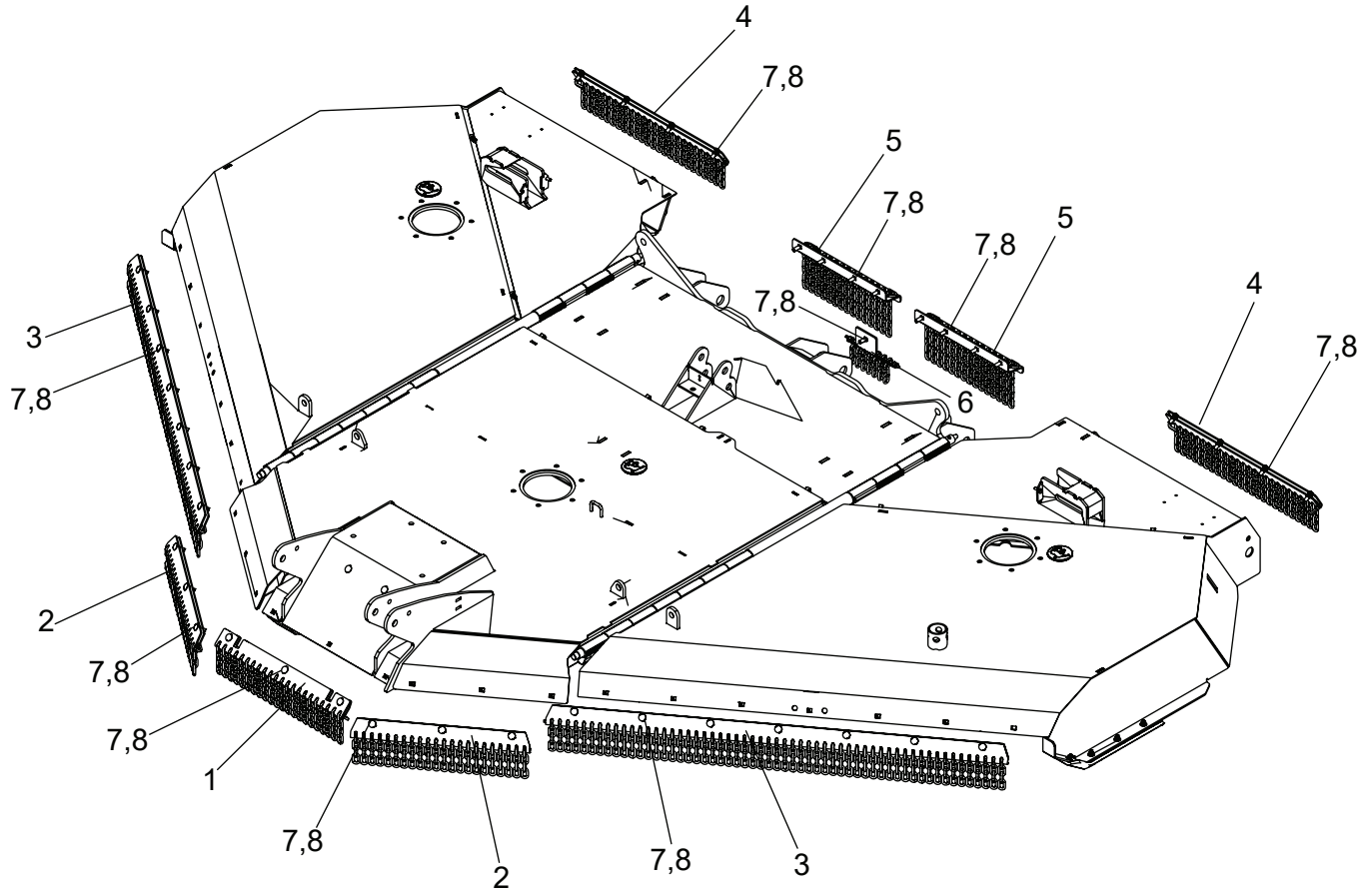

Item No.	Part No.	Description	Qty.	Item No.	Part No.	Description	Qty.
1	50083474	Double - Xfer Chain Assy.	1	5	50083478	Double Rear Center Chain Assy.	2
	50083278	Front Center Chain Bracket	1		50083284	Rear Chain Bracket	1
	50083222	Bent Chain Rod, 21 Link	1		50083325	Bent Chain Rod, 15 Link	1
	50017212	Chain, 7 Link, Plated	22		50017213	Chain, 11 Link	15
2	50084140	Double Front Center Chain Assy.	2	6	50083480	Double Chain Filler Assy.	1
	50084138	Center Side Chain Bracket	1		50083241	Rear Chain Mount	1
	50083222	Bent Chain Rod, 21 Link	1		50073323	Chain Cable	1
	50017212	Chain, 7 Link, Plated	22		50050408	Stop Sleeve	2
3	50083470	Double Front Wing Chain Assy.	2		50017264	Plated Chain, 5 Link	7
	50083280	Front Wing Chain Bracket	1	7	5161614	Carriage Bolt 1/2" x 1-1/2" G5 ZP	40
	50083215	Bent Chain Rod, 54 Link	1	8	44998BH	Locknut, 1/2" CNTR. Flng GR F CP	40
	50017212	Chain, 7 Link, Plated	57				
4	50083476	Double Rear Wing Chain Assy.	2				
	50083282	Rear Wing Chain Bracket	1				
	50083324	Bent Chain Rod, 25 Link	1				
	50017212	Chain, 7 Link, Plated	25				

CENTER SHIELD ASSEMBLY

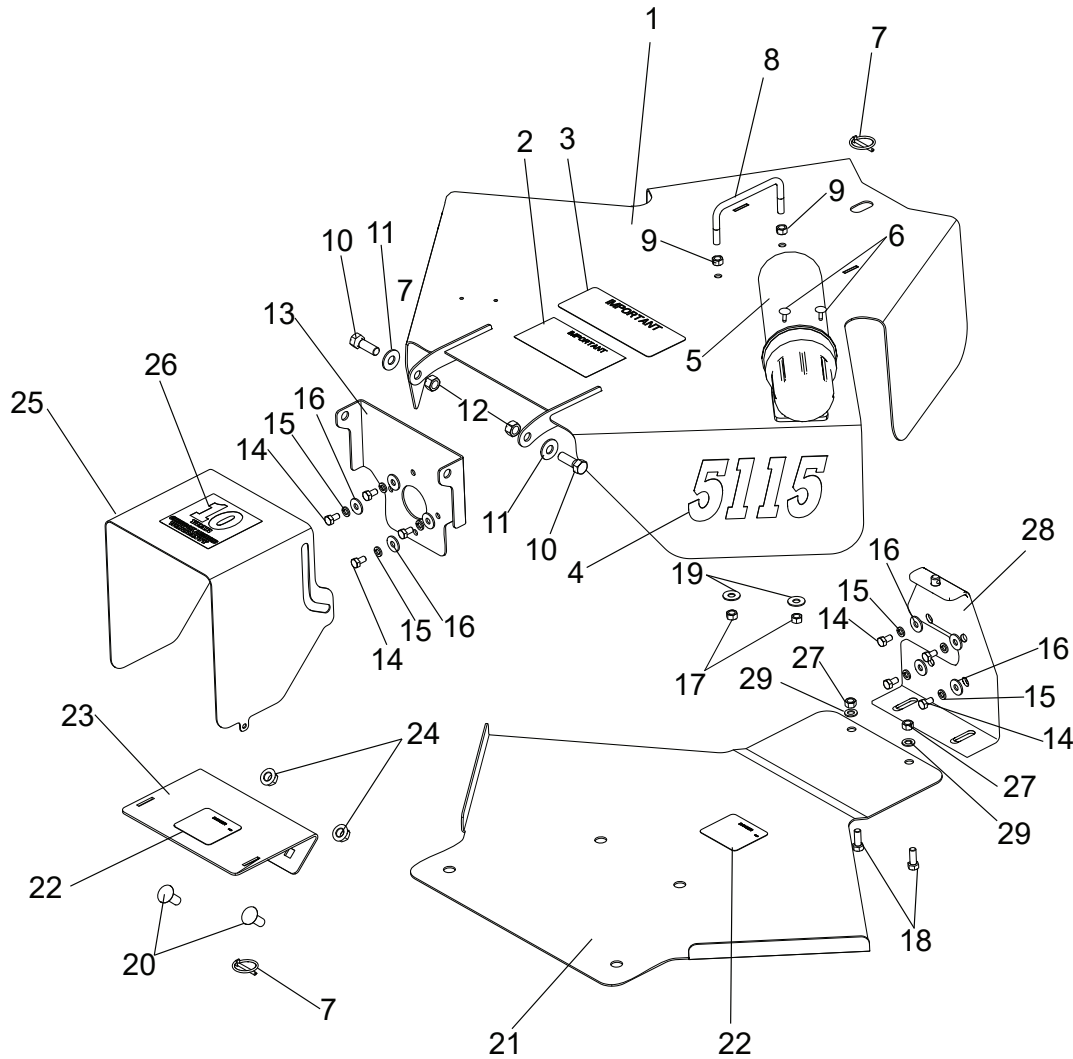

Item No.	Part No.	Description	Qty.	Item No.	Part No.	Description	Qty.
1	50083150	Center Shield w/Decals	1	14	90560	HHCS, M8 x 1.25 x 15 W/Patch	8
2	91443	Decal, Important	1	15	44311BH	Lockwasher, M8 ZP	8
3	87340	Decal, Important	1	16	44216	Flatwasher, M8 ZP	8
4	50083784	Decal, Model 5115	2	17	20363	Locknut, 3/8" CP	2
	50083785	Decal, Model 15115	2	18	20034	HHCS, 3/8" x 1" G5 ZP	2
	50083786	Decal, Model 5110	2	19	15915BH	Flatwasher, 3/8" ZP	2
	50083787	Decal, Model 15110	2	20	5161612	Carriage Bolt, 1/2" x 1-1/4" G5 ZP	2
5	50035829	Owners Manual Tube	1	21	50083439	Bottom Transfer Shield w/Decals	1
6	00780878	Rivet, 3/6" Pop-Grip .468	3	22	D546	Decal, Danger - Guard Missing	2
7	69391	Lynch Pin	2	23	50083438	Input Shield w/Decals	1
8	50027637	U-Bolt, Foot Platform	1	24	44998BH	Locknut, 1/2" CNTR. Fling GR F CP	2
9	8151200	Hex Nut, 3/8" CP	2	25	50083027	Input Shield, Top	1
10	15093	Hex Hd Capscrew, 1/2" x 1-1/2" G5 ZP	2	26	50081789	Decal, Gearbox Warranty	1
11	15916	Flatwasher, 1/2" CP	2	27	9131200	Locknut, 3/8" GRC CP	2
12	15554	Locknut, 1/2" CP	2	28	50070528	Rear Shield Support Weldment	1
13	50083218	Shield Mount	1	29	15830	Flatwasher, 3/8" SAE ZP	2

WING DRIVELINE SHIELDING

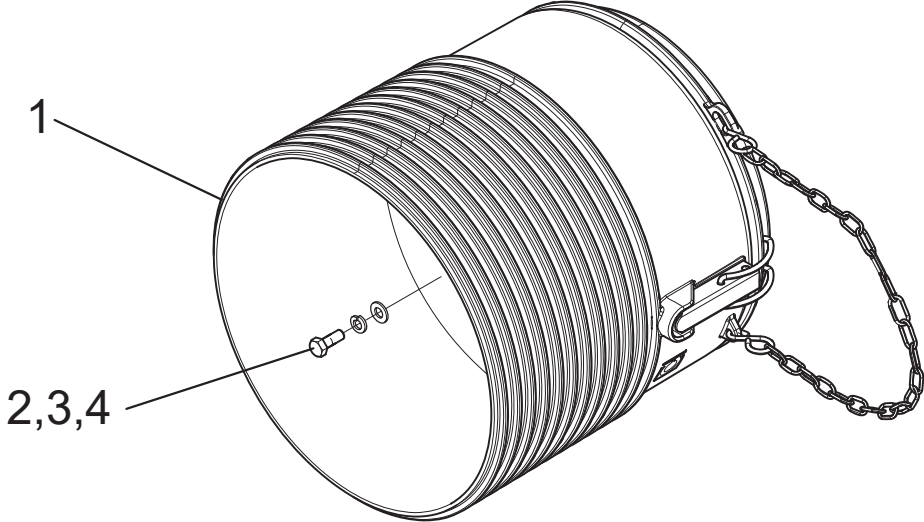

Item No.	Part No.	Description	Qty.
1	50062095	Driveline Shield Cone	1
2	90560	Capscrew, M8 x 1.25 x 15	4
3	44311BH	Lockwasher, M8	4
4	44216	Flatwasher, M8	4

LED LIGHT KIT (REAR LIGHTS ONLY) 50074720 5115RR1 & 15115RR1

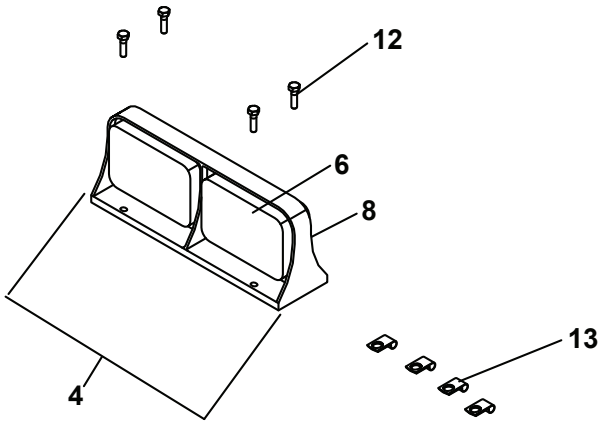

LEFT SIDE

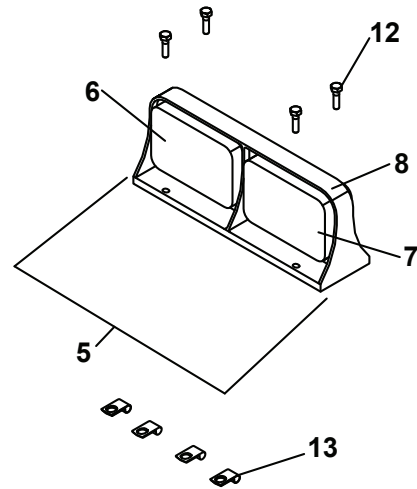
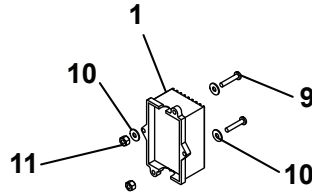
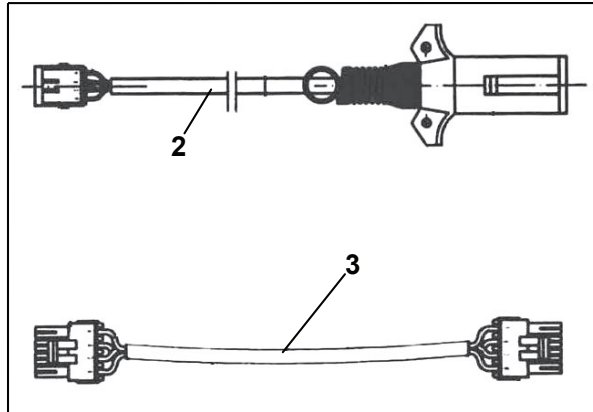

RIGHT SIDE

Item No.	Part No.	Description	Qty.
	50074720	Light Kit (items 1-8)	1
1	50072057	Module, Enhance	1
2	50074721	Main Harness (7 Pin, 16' Log)	1
3	50074725	Wishbone Harness, (8' Long)	2
4	50074723	Dual LED Ag. Lamp, Left Side, Amber/Red	1
5	50074724	Dual LED Ag. Lamp, Right Side, Red/Amber	1
6	50072062	Lens, Red Replacement	2
7	50072063	Lens, Amber Replacement	2
8	50072064	Cover, Black Replacement Lens	4
9	-----	Slit. Pn. Hd. Mach Screw #10 x 1"	2
10	17020600	Flatwasher, #10	4
11	44520BH	Locknut, #10	2
12	45350BH	Hex Flng Hd, 4 Thrd Cut Type F 1/4" x 3/4" ZP	8
13	50083661	P-Clip, 1/2"	6

LED LIGHT KIT (REAR LIGHTS ONLY) 50075213 5110RR1 & 15110RR1

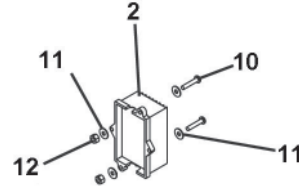
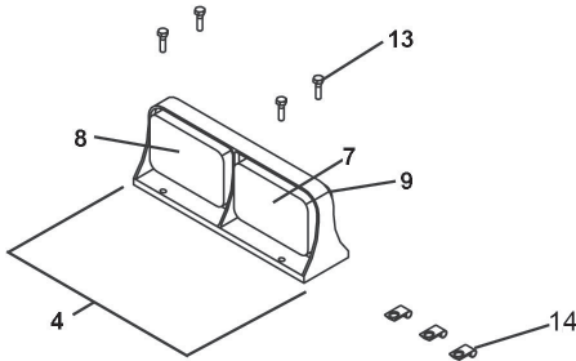

LEFT SIDE

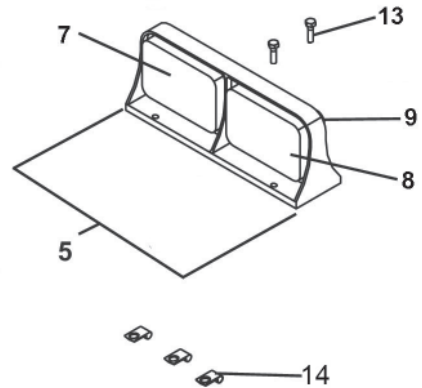
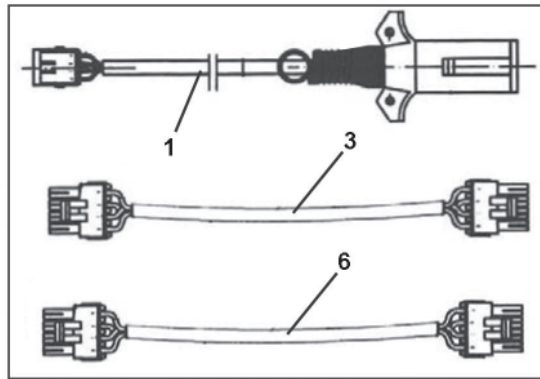

RIGHT SIDE

Item No.	Part No.	Description	Qty.
	50075213	Light Kit (items 1-9)	1
1	50074721	Main Harness (7 Pin, 16' Long)	1
2	50072057	Module, Enhance	1
3	50075028	Wishbone Harness (6' Long) Left	1
4	50074723	Dual LED Ag Lamp, Left Side, Amber/Red	1
5	50074724	Dual LED Ag Lamp, Right Side, Red/Amber	1
6	50074725	Wishbone Harness (8' Long)	1
7	50072062	Lens, Red Replacement	2
8	50072063	Lens, Amber Replacement	2
9	50072064	Cover, Black Replacement Lens	4
10	-----	Slit Pn Hd Mach Screw, #10 x 1"	2
11	17020600	Flatwasher, #10	4
12	44520BH	Locknut, #10	2
13	45350BH	Hex Flng Hd, 4 Thrd Cut Type F 1/4" x 3/4" ZP	8
14	50083661	P-Clip, 1/2"	6

71202 TRANSFER GEARBOX ASSEMBLY - 540 RPM MFG. BY COMER 5110RR1 & 5115RR1

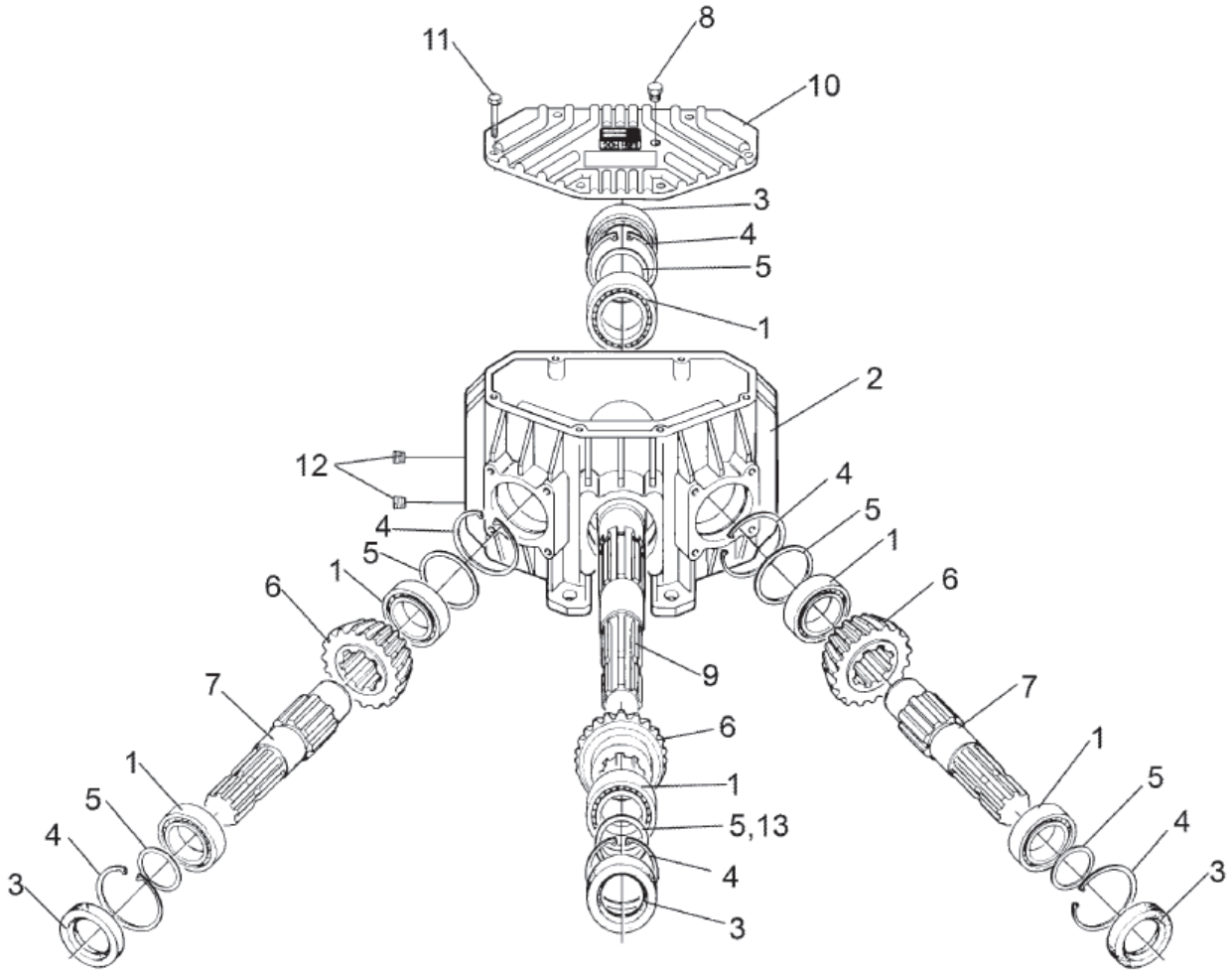

Item No.	Part No.	Description	Qty.
	71202	Assembly, Transfer Gearbox	1
1	70796	Bearing	6
2	76671	Casing	1
3	50068116	Oil Seal	4
4	70881	Snap Ring	6
5	70752	Shim, .3	6
6	50076037	Gear Kit (1 - 24T & 2 - 20T Gears)	1
7	76673	Shaft, 1-3/4" Z20	2
8	80538	Vent Plug	1
9	76678	Shaft, 1-3/4" Z20	1
10	76676	Cover	1
11	44489BH	Capscrew, M10 x 1.5 x 35 Gr. 8.8	6
12	70181	Gas Plug, 3/8"	2
13	70753	Shim, .4	6
	70754	Shim, .5	6
	70755	Shim, 1.0	6

50072724 TRANSFER GEARBOX ASSEMBLY - 1000 RPM MFG BY COMER 15110RR1 & 15115RR1

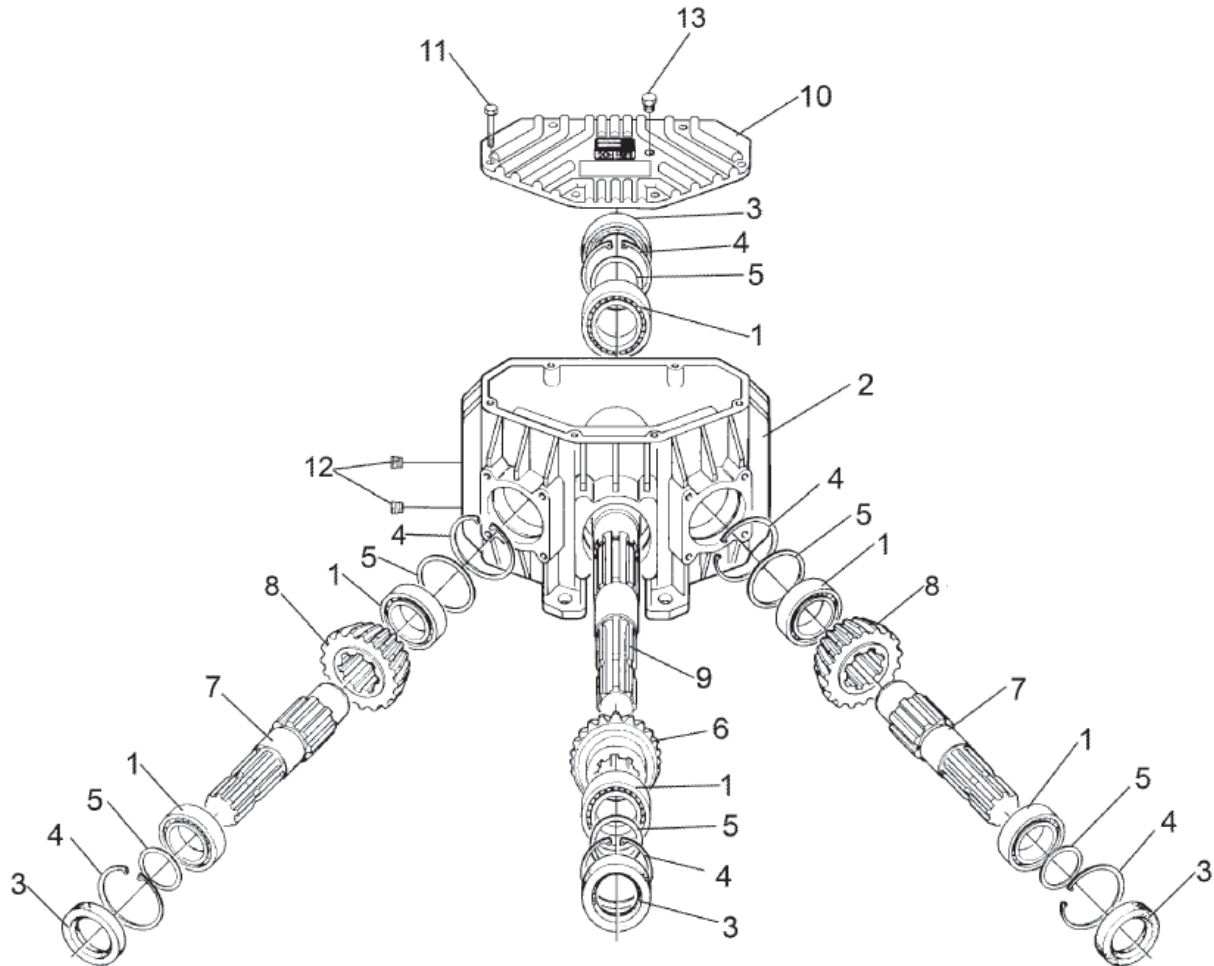

Item No.	Part No.	Description	Qty.
	50072724	Assembly, Transfer Gearbox	1
1	70796	Bearing	6
2	76671	Casing	1
3	50068116	Oil Seal	4
4	70881	Snap Ring	6
5	70752	Shim, .3	6
6	50075082	Gear Set (1000 RPM)	1
7	76673	Shaft, 1-3/4" Z20	2
8	50075082	Gear Set (1000 RPM)	2
9	76675	Shaft, 1-3/4" Z20	1
10	76676	Cover	1
11	44489BH	Capscrew, M10 x 1.5 x 35 Gr. 8.8	6
12	70181	Gas Plug, 3/8"	2
13	80538	Vent Plug	1

50071561BH - GEARBOX ASSY, EZ225B, RATIO 1:1.6 (540 RPM)
CENTER - 5110RR1 & 5115RR1 / LH WING - 5115RR1

50071563BH - GEARBOX ASSY, EZ225B, RATIO 1.15:1, (1000 RPM)
CENTER - 15110RR1 & 15115RR1

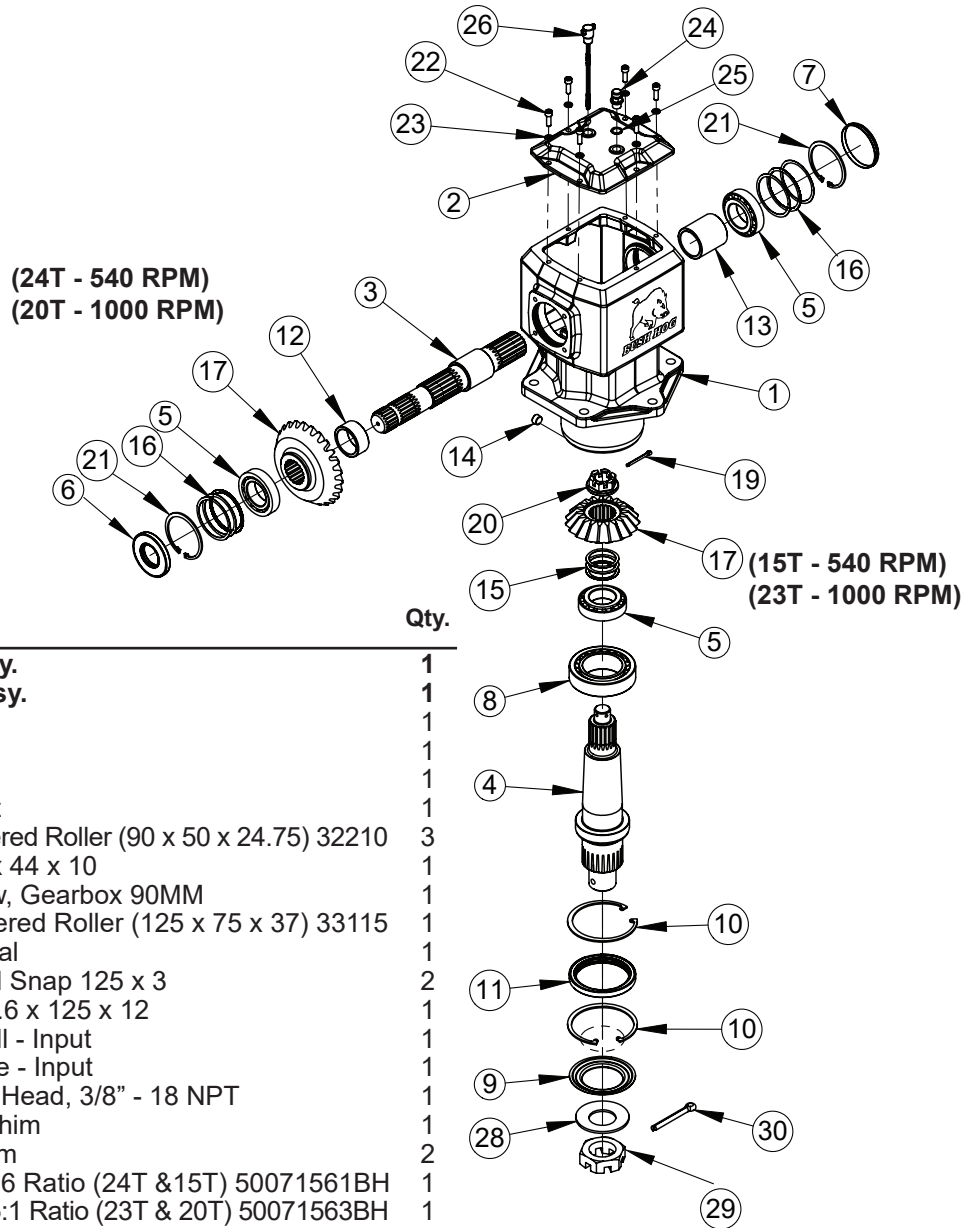

Item No.	Part No.	Description	Qty.
	50071561BH	Gearbox Assy.	1
	50071563BH	Gearbox Assy.	1
1	-----	Housing	1
2	00790887	Cap, Top	1
3	00790924	Shaft, Input	1
4	50069790	Shaft, Output	1
5	00779007	Bearing, Tapered Roller (90 x 50 x 24.75) 32210	3
6	00790889	Seal, Oil 90 x 44 x 10	1
7	50074090	Sight Window, Gearbox 90MM	1
8	00790928	Bearing, Tapered Roller (125 x 75 x 37) 33115	1
9	50069791	Protector, Seal	1
10	00790931	Ring, Internal Snap 125 x 3	2
11	00790930	Seal, Oil 101.6 x 125 x 12	1
12	00790932	Spacer, Small - Input	1
13	00790933	Spacer, Large - Input	1
14	13033	Plug, Socket Head, 3/8" - 18 NPT	1
15	00790939	Kit, HD225 Shim	1
16	00790892	Kit, Input Shim	2
17	00790934	Kit, Gear 1:1.6 Ratio (24T & 15T) 50071561BH	1
	00790947	Kit, Gear 1.15:1 Ratio (23T & 20T) 50071563BH	1
19	70497	Cotter Pin, M5 x 50	1
20	00790937	Hex Nut, Slotted Flg. M30-2.0	1
21	00790891	Ring, Internal Snap, 90 x 3	2
22	00790896	Bolt, Socket Hd. M8 x 1.25 x 20	6
23	701611C	Lockwasher, M8	6
24	00790985	Plug, Vent M16 - 1.5	1
25	00790983	Washer, Sealing M16	1
26	4038612	Dipstick, Oil	1
28	50071362	Washer, Spring, 2"	1
29	50071363	Hex Nut, Slotted Jam 2" - 12"	1
30	50071364	Cotter Pin, 10MM x 100MM	1

50071562BH - GEARBOX ASSY., EZ225B, RATIO 1:1.6 (540 RPM) RH WING - 5110RR1 & 5115RR1

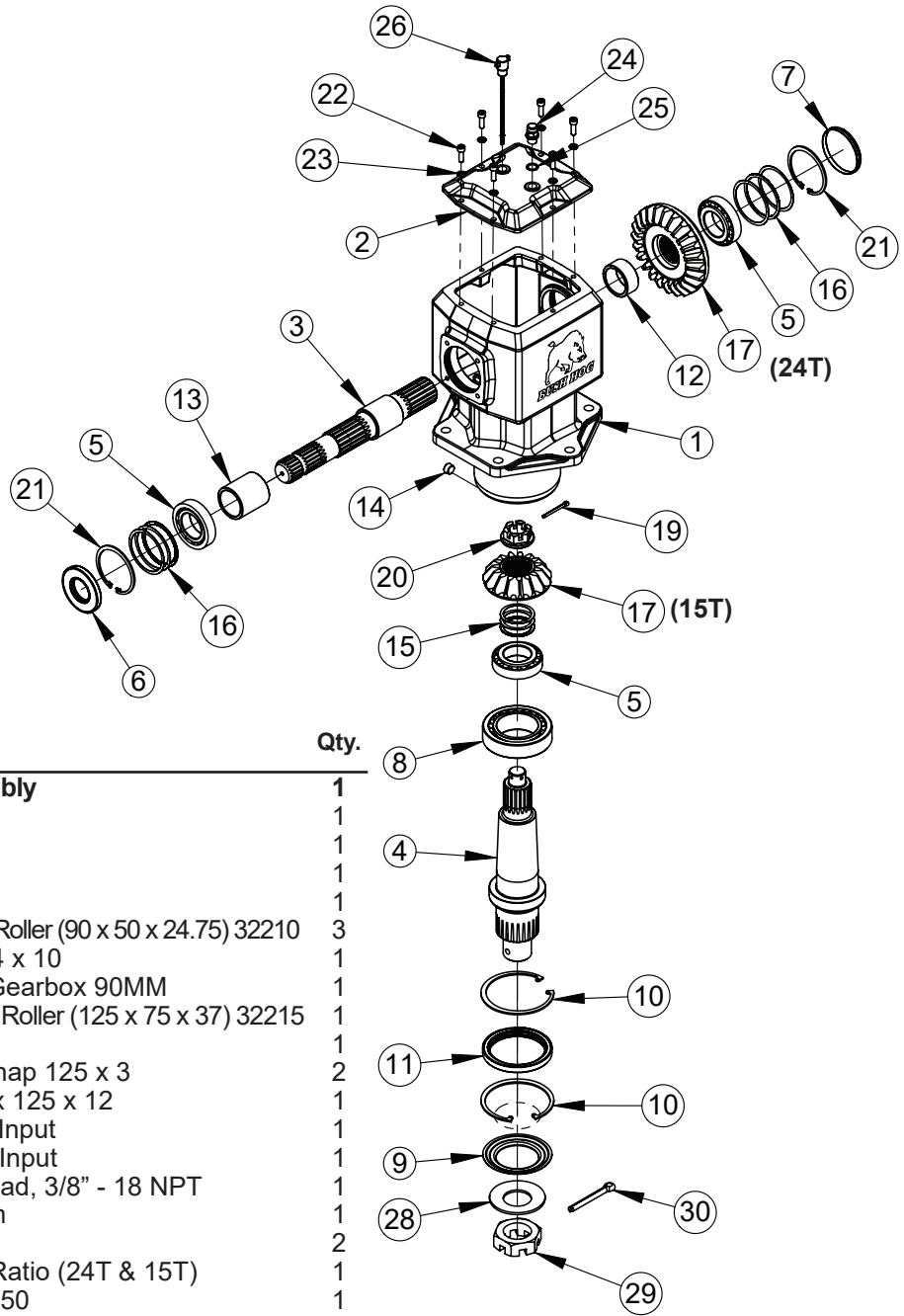

Item No.	Part No.	Description	Qty.
	50071562BH	Gearbox Assembly	1
1	-----	Housing	1
2	00790887	Cap, Top	1
3	00790924	Shaft, Input	1
4	50069790	Shaft, Output	1
5	00779007	Bearing, Tapered Roller (90 x 50 x 24.75) 32210	3
6	00790889	Seal, Oil 90 x 44 x 10	1
7	50074090	Sight Window, Gearbox 90MM	1
8	00790928	Bearing, Tapered Roller (125 x 75 x 37) 32215	1
9	50069791	Protector, Seal	1
10	00790931	Ring, Internal Snap 125 x 3	2
11	00790930	Seal, Oil 101.6 x 125 x 12	1
12	00790932	Spacer, Small - Input	1
13	00790933	Spacer, Large - Input	1
14	13033	Plug, Socket Head, 3/8" - 18 NPT	1
15	00790939	Kit, HD225 Shim	1
16	00790892	Kit, Input Shim	2
17	00790934	Kit, Gear 1:1.6 Ratio (24T & 15T)	1
19	70497	Cotter Pin M5 x 50	1
20	00790937	Hex Nut, Slotted Flg. M30-2.0	1
21	00790891	Ring, Internal Snap, 90 x 3	2
22	00790896	Bolt, Socket Hd. M8 x 1.25 x 20	6
23	701611C	Lockwasher, M8	6
24	00790985	Plug, Vent M16 - 1.5	1
25	00790983	Washer, Sealing M16	1
26	4038612	Dipstick, Oil	1
28	50071362	Washer, Spring 2"	1
29	50071363	Hex Nut, Slotted Jam 2" x 12	1
30	50071364	Cotter Pin, 10MM x 100MM	1

50071564BH - GEARBOX ASSY., EZ225B, RATIO 1:1.375 (1000 RPM) LH WING - 15115RR1

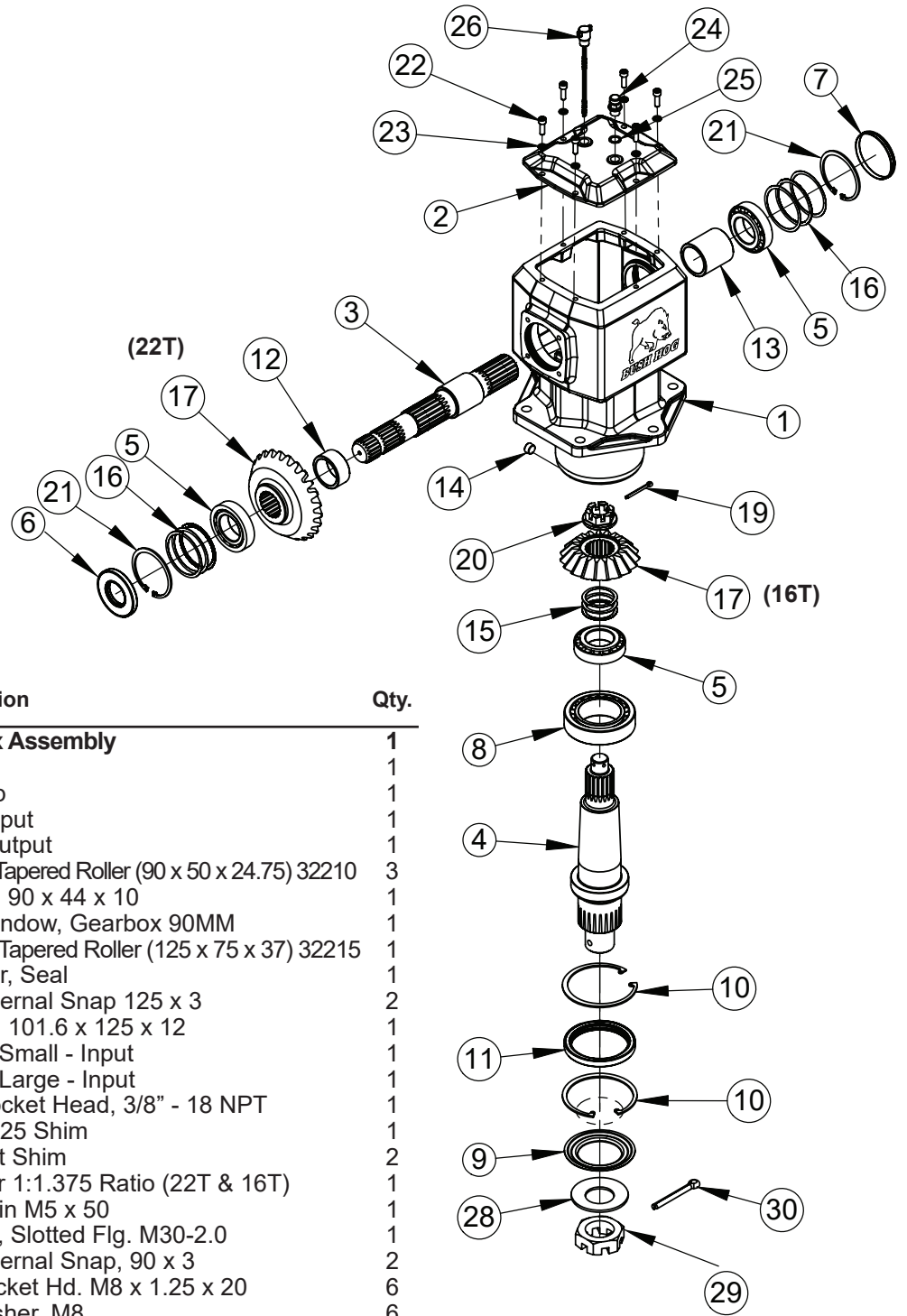

Item No.	Part No.	Description	Qty.
	50071564BH	Gearbox Assembly	1
1	-----	Housing	1
2	00790887	Cap, Top	1
3	00790924	Shaft, Input	1
4	50069790	Shaft, Output	1
5	00779007	Bearing, Tapered Roller (90 x 50 x 24.75) 32210	3
6	00790889	Seal, Oil 90 x 44 x 10	1
7	50074090	Sight Window, Gearbox 90MM	1
8	00790928	Bearing, Tapered Roller (125 x 75 x 37) 32215	1
9	50069791	Protector, Seal	1
10	00790931	Ring, Internal Snap 125 x 3	2
11	00790930	Seal, Oil 101.6 x 125 x 12	1
12	00790932	Spacer, Small - Input	1
13	00790933	Spacer, Large - Input	1
14	13033	Plug, Socket Head, 3/8" - 18 NPT	1
15	00790939	Kit, HD225 Shim	1
16	00790892	Kit, Input Shim	2
17	00790950	Kit, Gear 1:1.375 Ratio (22T & 16T)	1
19	70497	Cotter Pin M5 x 50	1
20	00790937	Hex Nut, Slotted Flg. M30-2.0	1
21	00790891	Ring, Internal Snap, 90 x 3	2
22	00790896	Bolt, Socket Hd. M8 x 1.25 x 20	6
23	701611C	Lockwasher, M8	6
24	00790985	Plug, Vent M16 - 1.5	1
25	00790983	Washer, Sealing M16	1
26	4038612	Dipstick, Oil	1
28	50071362	Washer, Spring 2"	1
29	50071363	Hex Nut, Slotted Jam 2" x 12	1
30	50071364	Cotter Pin, 10MM x 100MM	1

50071565BH - GEARBOX ASSY., EZ225B, RATIO 1:1.375 (1000 RPM) RH WING - 15110RR1 & 15115RR1

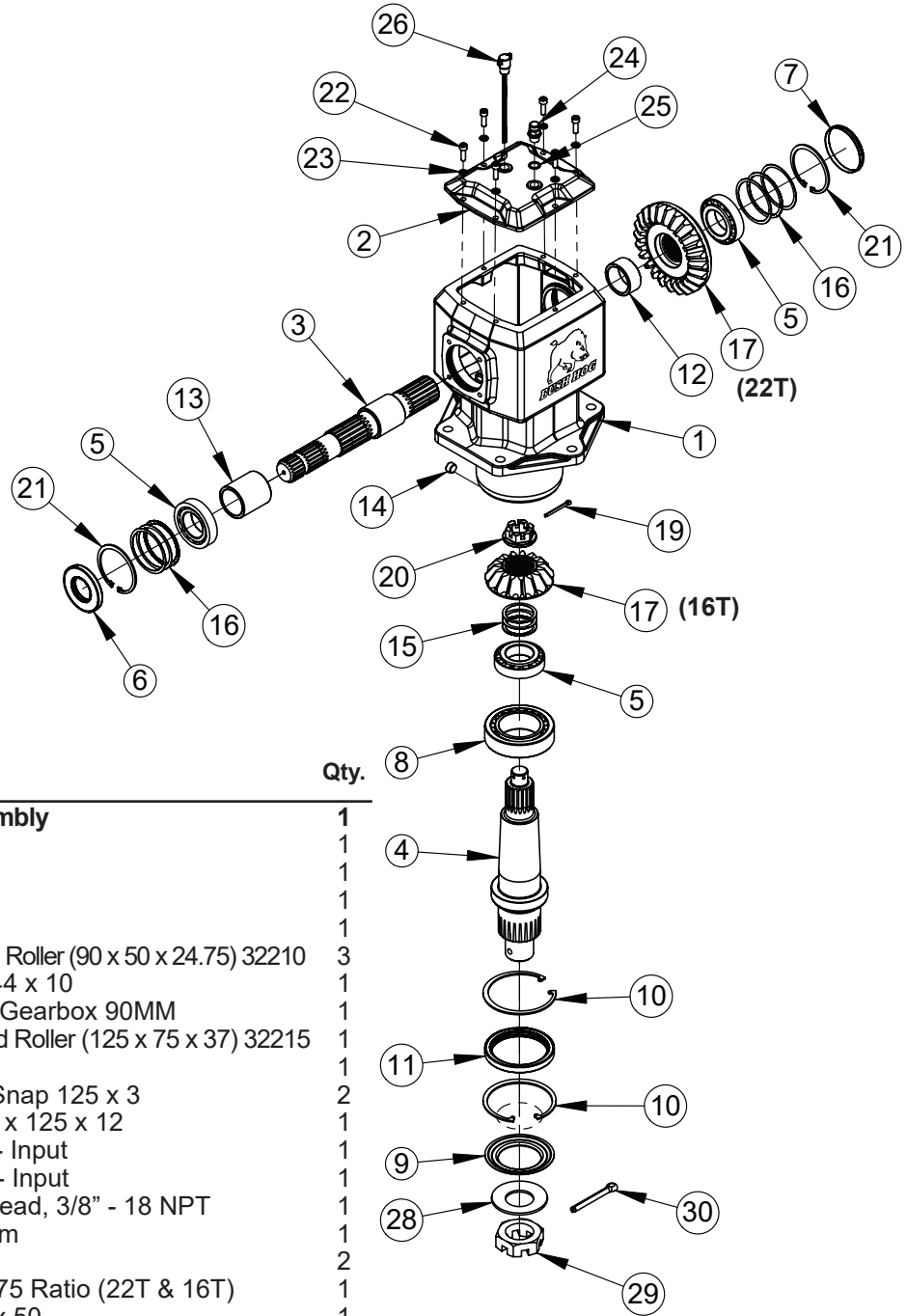

Item No.	Part No.	Description	Qty.
	50071565BH	Gearbox Assembly	1
1	-----	Housing	1
2	00790887	Cap, Top	1
3	00790924	Shaft, Input	1
4	50069790	Shaft, Output	1
5	00779007	Bearing, Tapered Roller (90 x 50 x 24.75) 32210	3
6	00790889	Seal, Oil 90 x 44 x 10	1
7	50074090	Sight Window, Gearbox 90MM	1
8	00790928	Bearing, Tapered Roller (125 x 75 x 37) 32215	1
9	50069791	Protector, Seal	1
10	00790931	Ring, Internal Snap 125 x 3	2
11	00790930	Seal, Oil 101.6 x 125 x 12	1
12	00790932	Spacer, Small - Input	1
13	00790933	Spacer, Large - Input	1
14	13033	Plug, Socket Head, 3/8" - 18 NPT	1
15	00790939	Kit, HD225 Shim	1
16	00790892	Kit, Input Shim	2
17	00790950	Kit, Gear 1:1.375 Ratio (22T & 16T)	1
19	70497	Cotter Pin M5 x 50	1
20	00790937	Hex Nut, Slotted Flg. M30-2.0	1
21	00790891	Ring, Internal Snap, 90 x 3	2
22	00790896	Bolt, Socket Hd. M8 x 1.25 x 20	6
23	701611C	Lockwasher, M8	6
24	00790985	Plug, Vent M16 - 1.5	1
25	00790983	Washer, Sealing M16	1
26	4038612	Dipstick, Oil	1
28	50071362	Washer, Spring 2"	1
29	50071363	Hex Nut, Slotted Jam 2" x 12	1
30	50071364	Cotter Pin, 10MM x 100MM	1

50058536 CENTER DRIVELINE ASSEMBLY 1-3/4" - 20 SPLINE, ASAE 4 Manufactured by Comer/EG

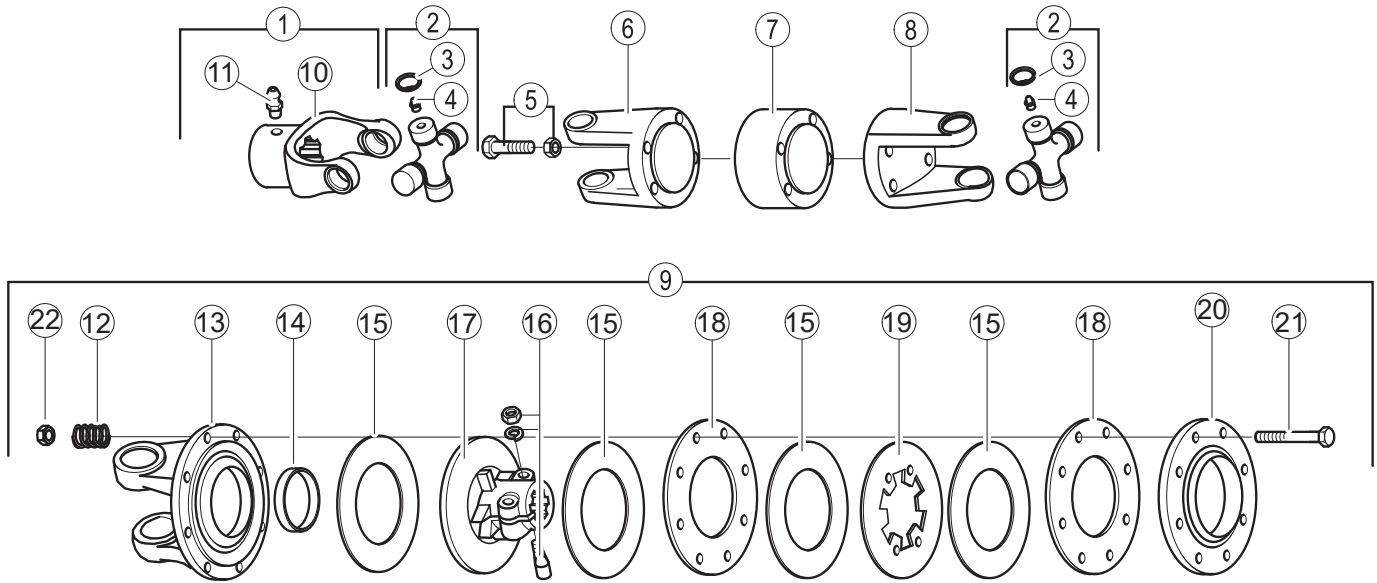

Item No.	Part No.	Description	Qty.
	50058536	Center Driveline Assembly	1
1	76782	Yoke w/Grease Nipple	1
2	50060543	Cross Journal Set	2
3	-----	CirClip	8
4	76335	Grease Nipple	2
5	76965	Capscrew, M12 x 1.25 x 90 Gr. 12.9 w/Locknut M12	4
6	76305	Flanged Yoke, Male	1
7	76306	Retaining Washer	1
8	76307	Flanged Yoke, Female	1
9	76456	Clutch Assembly	1
10	-----	Yoke	1
11	63946	Grease Nipple	1
12	76080	Spring	8
13	76164	Flanged Yoke	1
14	76082	Bushing	1
15	76083	Lining Ring	4
16	76247	Tapered Pin Kit	1
17	76458	Clutch Support	1
18	76085	Inner Plate	2
19	76197	Intermediate Plate	1
20	76086	Pressure Plate	1
21	44159BH	Capscrew, M10 x 1.5 x 100 Gr. 8	8
22	44154BH	Locknut, M10 x 1.5	8

50071111 WING DRIVELINE ASSEMBLY W/CLUTCH

1-3/4" Z20, ASAE SIZE 5

Manufactured by Comer/EG

5110RR1 & 5115RR1 & 15110RR1 & 15115RR1

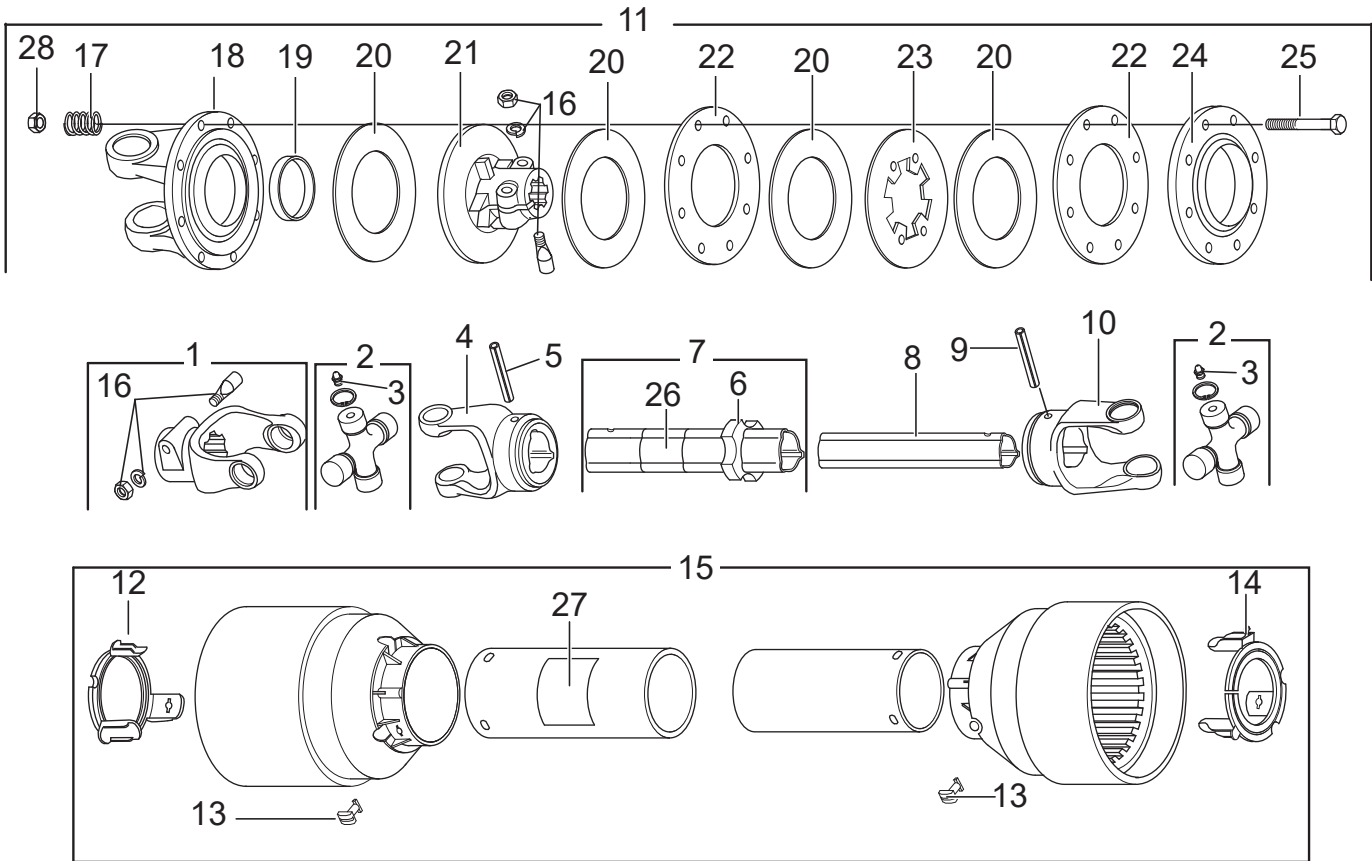

Item No.	Part No.	Description	Qty.	Item No.	Part No.	Description	Qty.
	50071111	Driveshaft Assembly	1	15	50072387	Guard Assy. Complete	1
1	76239BH	Yoke Assembly	1	16	76247	Tapered Pin Set	2
2	76998	Cross Journal Kit	2	17	76080	Spring	8
3	76335	Grease Fitting	2	18	76331	Flanged Yoke	1
4	78134	Outer Yoke	1	19	76082	Bushing	1
5	67108	Roll Pin Outer Yoke	1	20	76083	Lining Ring	4
6	76274	Bushing w/Fitting	1	21	76458	Support	1
7	50072385	Outer Tube Assy	1	22	76085	Inner Plate	2
8	50072386	Inner Tube	1	23	76197	Intermediate Plate	1
9	67085	Roll Pin Inner Yoke	1	24	76086	Pressure Plate	1
10	67086	Inner Yoke	1	25	44159BH	Capscrew, M10 x 1.5 x 100	8
11	50061008	Clutch Assy	1	26	78786	Decal, Danger, Outer Tube	1
12	50056403	Retaining Collar Outer	1	27	78608	Decal, Danger, Outer Shield	1
13	50056404	Bolt	6	28	44154BH	Hex Nut, M10 x 1.5 C9	8
14	50056405	Retaining Collar Inner	1				

50074699SP C.V. DRIVESHAFT
INPUT 1-3/4" - 20 Spline, ASAE Size 6
Manufactured by Comer/EG
14110R1, 14110RR1, 14115R1 & 14115RR1 (1000 RPM)

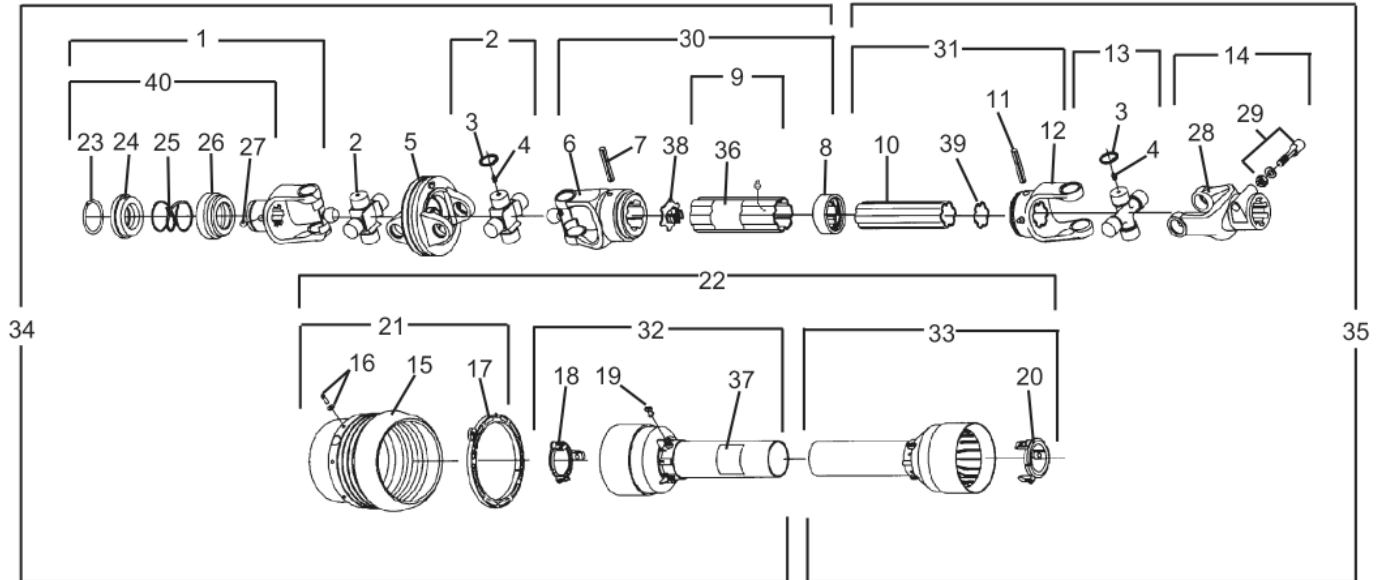

Item No.	Part No.	Description	Qty.	Item No.	Part No.	Description	Qty.
	50074699SP	Assembly, Driveline	1	21	50075192	Guard Cone Set	1
1	50056927	Complete Yoke	1	22	50075193	Complete Guard w/Inst. Manual	1
2	50056400	Cross Journal Set	2	23	-----	Outer Circlip	1
3	-----	Circlip	12	24	-----	Sliding Sleeve Collar	1
4	76335	Grease Nipple	3	25	-----	Spring	1
5	76357	Wide Angle Double Yoke	1	26	-----	Fixed Sleeve	1
6	76896	Outer Yoke	1	27	-----	Ball, 1/2"	3
7	67108	Roll Pin - Outer & Inner Tube	1	28	-----	Yoke	1
8	76897	Wiper	1	29	76247	Tapered Pin Set 1-3/4"	1
9	50075190	Complete Outer Tube	1	30	-----	Female Tube w/Yoke	1
10	50075191	Inner Tube	1	31	-----	Male Tube w/Yoke	1
11	67085	Roll Pin for Inner Tube	1	32	-----	Half Female Guarding w/Label	1
12	50071244	Inner Yoke	1	33	-----	Half Male Guarding	1
13	50056401	Cross Journal Set	1	34	-----	Half Female Shaft w/Guarding	1
14	76239BH	Complete Yoke	1	35	-----	Half Male Shaft w/Guarding	1
15	-----	Guard Cone	1	36	78786	Decal, Danger - Outer Tube	1
16	76362	Screw Kit	6	37	78608	Decal, Danger - Outer Guard Tube	1
17	50056402	Bearing Ring	1	38	76899	Plastic Cap - Outer Tube	1
18	50056403	Guard Ret. Collar - Outer Tube	1	39	50071247	Plastic Cap - Inner Tube	1
19	50056404	Bolt	6	40	50017502	Kit Collar for Yoke, 1-3/4"	1
20	50056405	Guard Ret. Collar - Inner Tube	1				

50083778SP C.V. DRIVESHAFT

Input: 1-3/8" - Z21, ASAE Size 6
15110RR1 & 15115RR1 (1000 RPM)

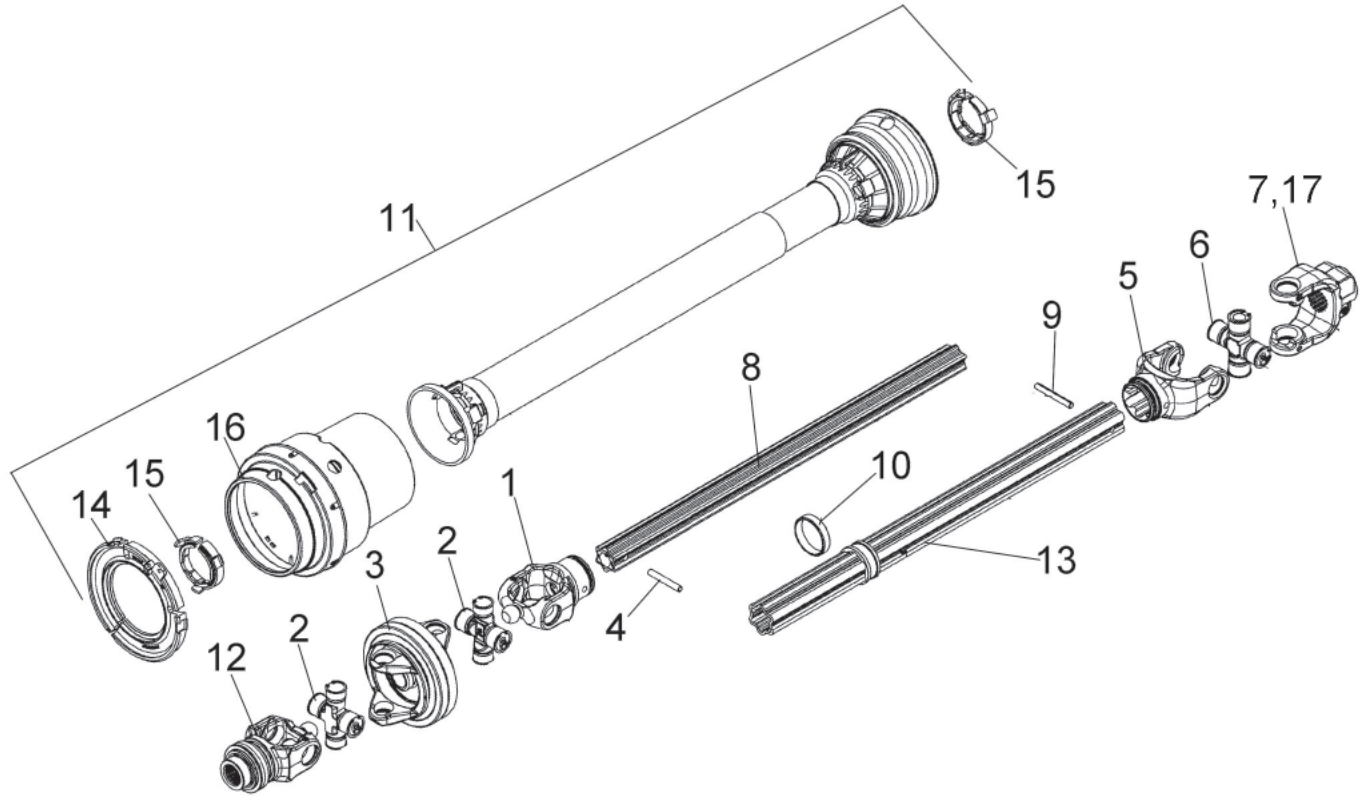

Item No.	Part No.	Description	Qty.
	50083778SP	Driveline Assembly, CV	1
1	50081634	Inner Tube CV Yoke	1
2	50081635	Universal Joint Assembly	2
3	50081636	CV Body	1
4	BH000-016E	Roll Pin, 10 x 70	1
5	50081640	Outer Tube Yoke	1
6	50056401	Cross Journal Set, Grease at End	1
7	76239BH	Complete Yoke 155	1
8	50083774	Inner Tube	1
9	00756934	Pin, Roll 10 x 80	1
10	50081645	Nylon Sleeve	1
11	50083775	CV Safety Guard Group	1
12	50083776	CV End Yoke w/Quick Lock	1
13	50083777	Outer Tube	1
14	50081648	Wide Angle Retainer	1
15	50081649	Retainer/Clip Evolution Series	2
16	50083030	CV Cone Kit	1
17	50084287	Conic Bolt Kit	1

50081632SP C.V. DRIVESHAFT INPUT: 1-3/8 - 6 CV ASAE 6 5110RR1 & 5115RR1 (540 RPM)

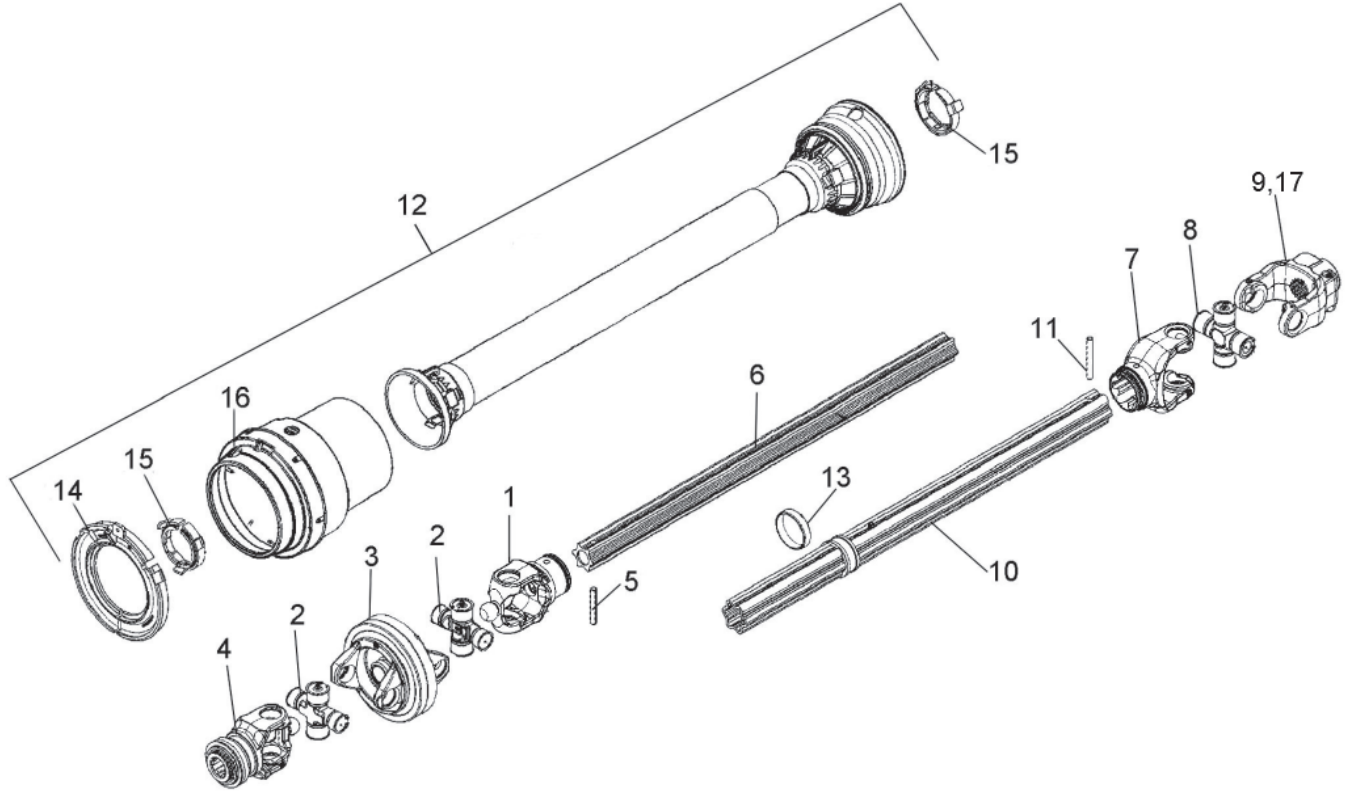

Item No.	Part No.	Description	Qty.
	50081632SP	Driveline Assembly, CV	1
1	50081634	Inner Tube CV Yoke	1
2	50081635	Universal Joint Assembly	2
3	50081636	CV Body	1
4	50081637	CV End Yoke w/Quick Lock	1
5	BH000-016E	Roll Pin, 10 x 70	1
6	50081639	Inner Tube	1
7	50081640	Outer Tube Yoke	1
8	50056401	Cross Journal Set, Grease at End	1
9	76239BH	Complete Yoke 155	1
10	50081642	Outer Tube	1
11	00756934	Pin, Roll 10 x 80	1
12	50081644	CV Safety Guard Group	1
13	50081645	Nylon Sleeve	1
14	50081648	Wide Angle Retainer	1
15	50081649	Retainer/Clip Evolution Series	2
16	50083030	CV Cone Kit	1
17	50084287	Conic Bolt Kit	1

TONGUE, LEVELING ROD & RELATED PARTS

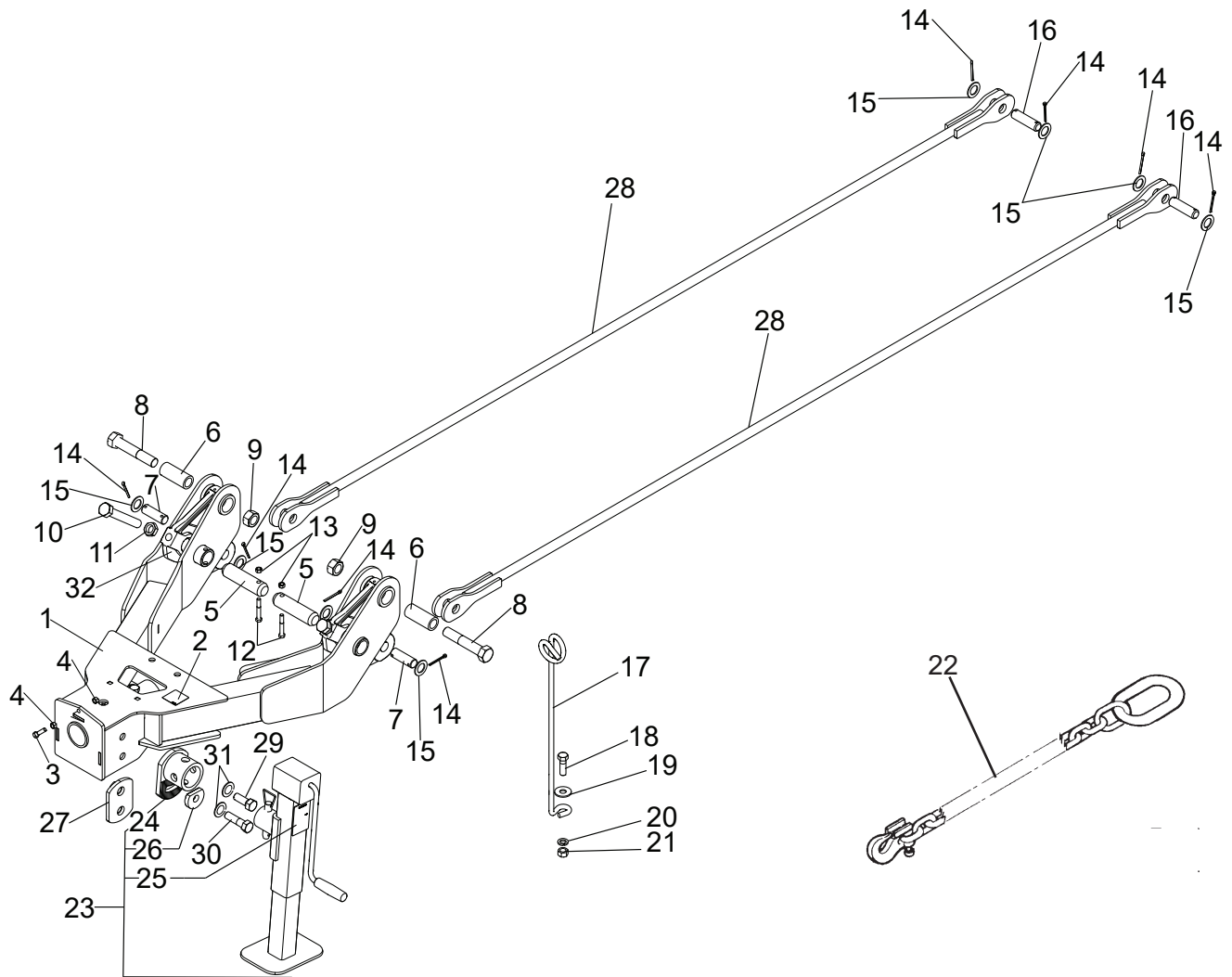

Item No.	Part No.	Description	Qty.	Item No.	Part No.	Description	Qty.
1	50083430	Tongue w/Decals	1	17	12031	Rod, Hose Holder	1
2	D1085	Decal, Notice	1	18	20947	Hex Hd Capscrew, 5/8" x 2" G5 ZP	1
3	1161212	Hex Hd Capscrew 3/8" x 1-1/4" G5 ZP	1	19	15925	Flatwasher, 5/8" ZP	1
4	8151200	Hex Nut, 3/8" CP	2	20	19486	Lockwasher, 5/8" CP	1
5	50083236	Leveling Pin, 1.50" x 5.75"	2	21	15563	Hex Nut, 5/8" CP	1
6	50083319	Sleeve Bushing	2	22	91074	Safety Tow Chain	1
7	92314	Pin (Swivel Link)	2	23	00779350	Jackstand (includes items 24, 25 & 26)	1
8	-----	Hex Hd Capscrew, 1" x 6" G5 ZP	2	24	00779360	Bracket, Jack Weldment	1
9	9163200	Locknut, 1" Gr. C CP	2	25	D482	Decal, Warning	1
10	45348BH	Hex Hd Capscrew, 7/8"-9 x 5" G8	2	26	00779361	Washer, Jack	1
11	10152800	Jamnut, 7/8" CP	2	27	50083144	Jack Plate Weldment	1
12	20224	Hex Hd Capscrew, 3/8" x 2-1/2" G5 ZP	2	28	50083145	Leveling Rod Weldment	2
13	20363	Locknut, 3/8" CP	2	29	20202	Hex Hd Capscrew, 3/4" x 2" G5 ZP	1
14	20167	Cotter Pin, 3/16" x 2" ZP	8	30	44065	Hex Hd Capscrew, 3/4" x 2-3/4" G5 ZP	1
15	20376	Flatwasher, 1" Gr. C CP	8	31	146	Lockwasher, 3/4" ZP	2
16	50018334	Pin, Turnbuckle	2	32	50082916	Cast Leveling Adjuster	2

DRIVELINE HOLDER ASSEMBLY

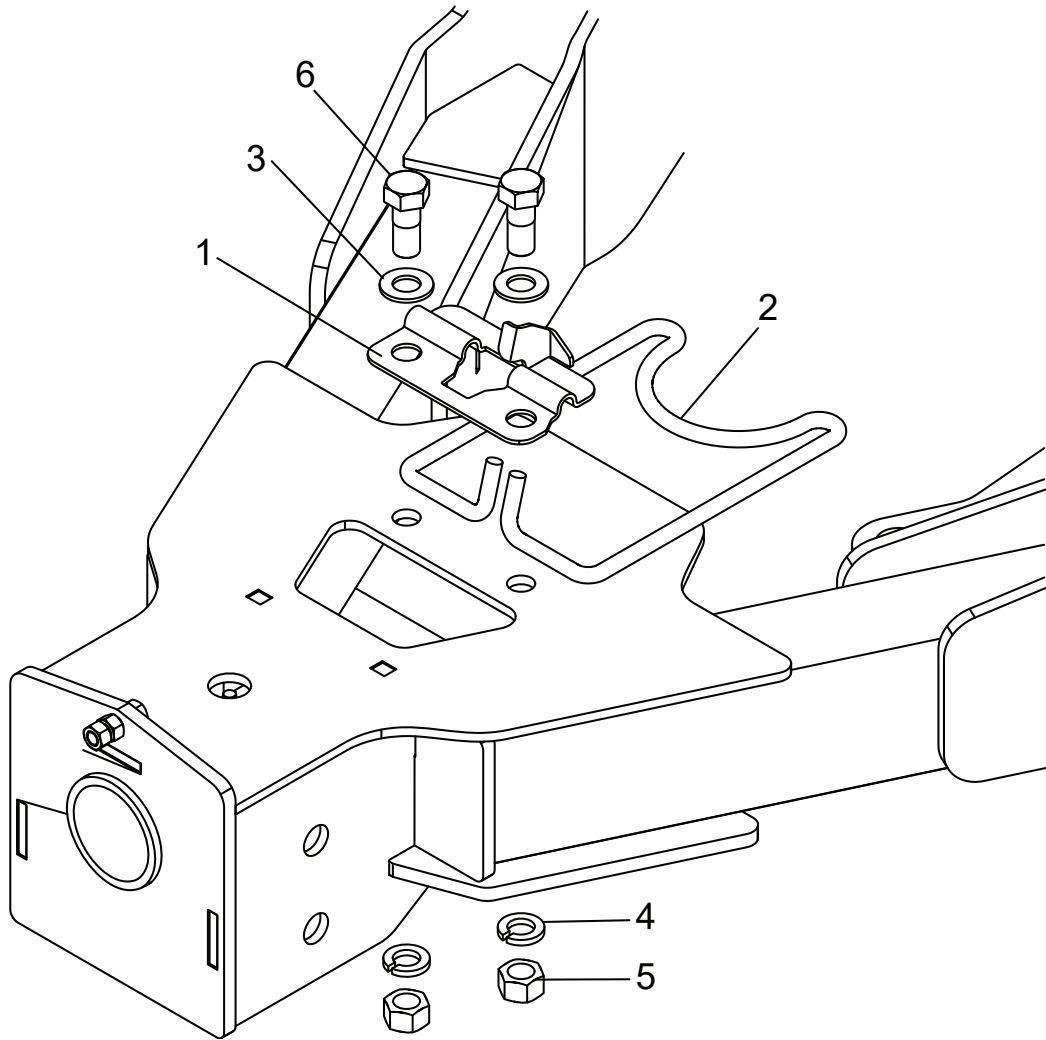

Item No.	Part No.	Description	Qty.
1	50054710	Mounting Bracket Weld.	1
2	50054711	Formed Driveline Holder	1
3	20748	Flatwasher, 5/8" SAE	2
4	19486	Lockwasher, 5/8"	2
5	15563	Hex Nut, 5/8"	2
6	20501	Capscrew, 5/8" x 1-1/2" G5 ZP	2
7	-----	Instruction Sheet (50083505)	1

50083676SP PERMA LEVEL HITCH ASSEMBLY

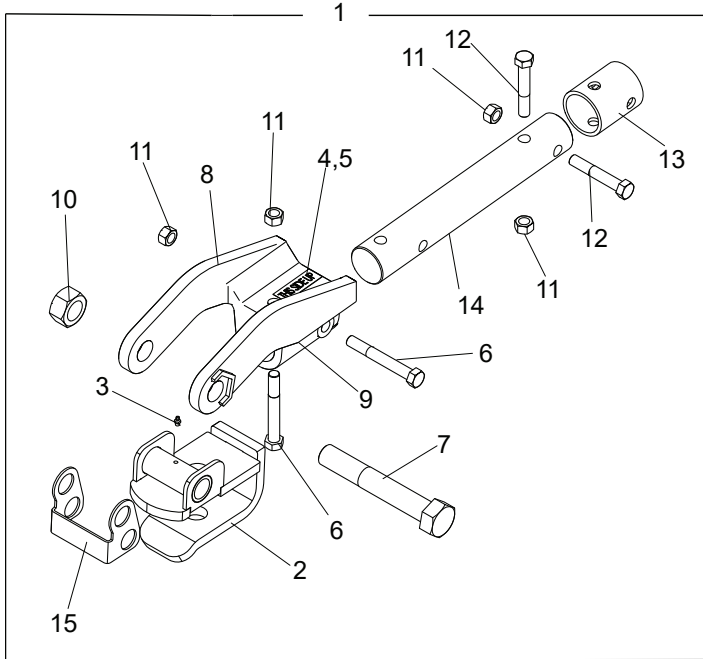

Item No.	Part No.	Description	Qty.
1	50083676SP	Perma Level Hitch Assy	1
2	50083147	Clevis Weldment	1
3	449BH	Grease Fitting	2
4	50035874	Decal, Direction	1
5	97692	Decal, Patent	1
6	44625	Capscrew, 5/8" x 4-3/4" G5 ZP	2
7	45324	Capscrew, 1-1/4" x 8" G5 ZP	1
8	50074196	Hitch w/Decals	1
9	50045639	Decal, Directional	1
10	15521	Locknut, 1-1/4" Gr. C Collar	1
11	15598BH	Locknut, 5/8" CP	4
12	44168BH	Capscrew, 5/8" x 3-3/4" G5 ZP	2
13	86356	Collar, Clevis Pin	1
14	50074187	Shaft	1
15	50083951	Perma Level Pin Holder	1

50083959 BALL HITCH ASSEMBLY

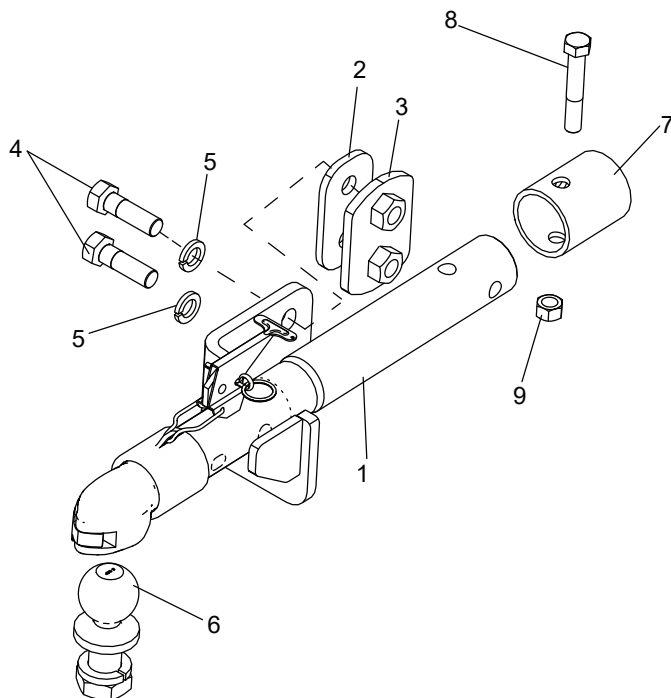

Item No.	Part No.	Description	Qty.
	50083959	Ball Hitch Assembly	1
1	50083956	Ball Hitch Weldment	1
2	50083957	Spacer, Ball Hitch	1
3	50083144	Jack Plate Weldment, ZP	1
4	1162424	Hex Hd Capscrew, 3/4" x 2-1/2" ZP	2
5	146	Lockwasher, 3/4" ZP	2
6	50068048	2-5/16" Hitch Ball Assembly	1
7	50084008	Collar, Ball Hitch	1
8	44796BH	Hex Hd Capscrew, 3/4" x 2-1/2" ZP	1
9	20638	Locknut, 3/4" CP	1

AXLES & RELATED PARTS (CENTER)

NOTE: Ref. No. 7 is NOT part of the Turnbuckle Assy. and must be ordered seperately.

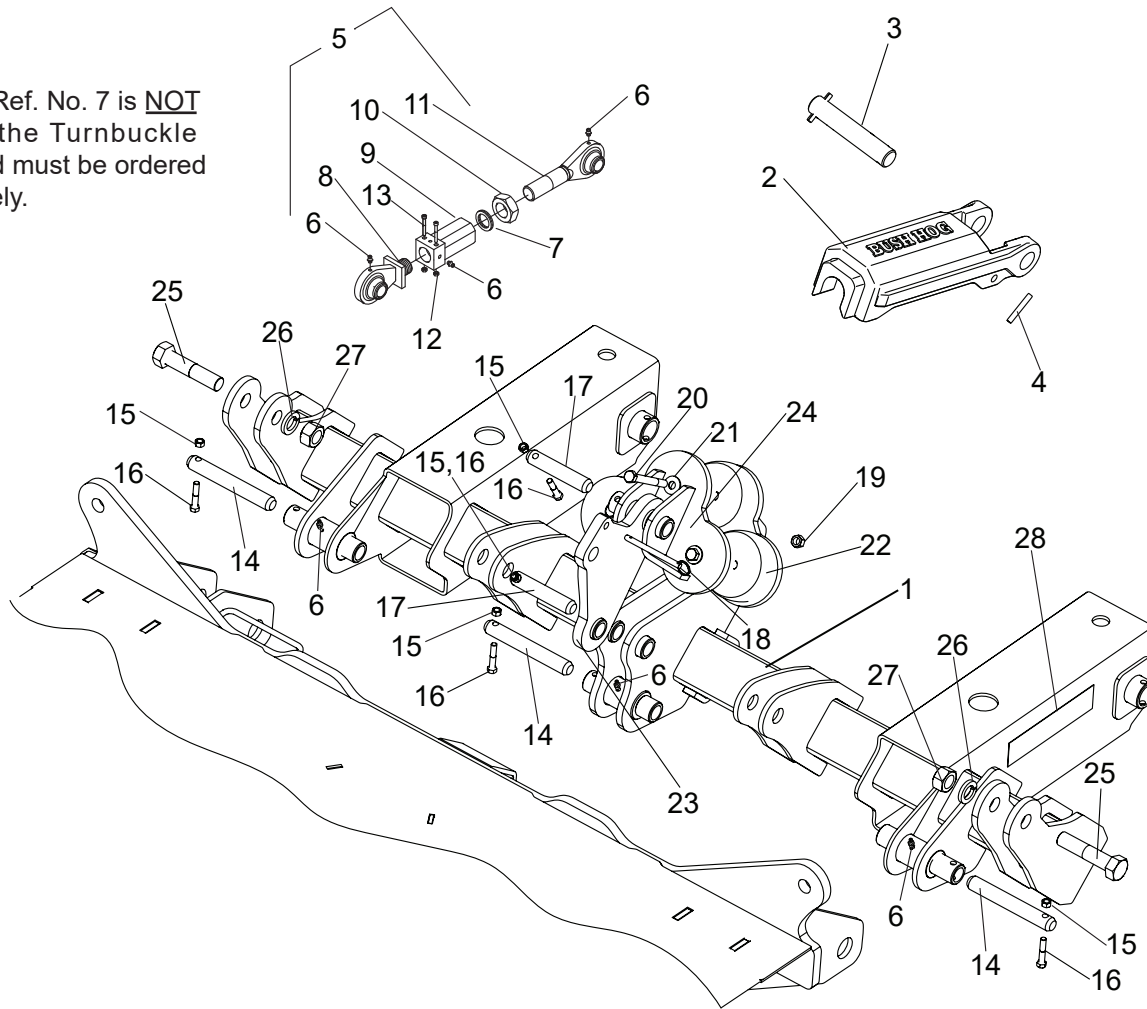

Item No.	Part No.	Description	Qty.	Item No.	Part No.	Description	Qty.
1	50083799	Center Axle Weldment	1	15	20363	Locknut, 3/8"	5
2	50083226	Cast Transfer Lock	1	16	1161220	Capscrew, 3/8" x 2" G5	5
3	87294	Cylinder Pin	1	17	50083285	Pivot Pin, 1" x 5.25"	2
4	20167	Cotter Pin, 3/16" x 2" ZP	2	18	50083675	3/8" Loop-Grip Clevis Pin w/ Hairpin Cotter Pin	1
5	50052742	Turnbuckle Assy.	2	19	44998BH	Locknut, 1/2" CNTR. FLNG.	3
6	449BH	Grease Fitting	6	20	20175	Hex Hd Capscrew, 1/2" x 4-1/2" G5 ZP	3
7	50038405	Nord-Lockwasher, 1-1/4"	1	21	15916	Flatwasher, 1/2" ZP	3
8	50052744	Rod Eye, Swivel	1	22	50083249	Donut Isolator	3
9	50052743	Turnbuckle Body	1	23	50083142	Hammer Weldment	1
10	50052746	Jamnut, 1-1/4"	1	24	50083149	Isolator Cyl. Mount Weldment	1
11	50052745	Rod Eye, Threaded	1	25	20547BH	Capscrew, 1" x 4-1/2" Gr. 5	2
12	45186	Locknut, 5/16" CP Center Lock	2	26	15821	Lockwasher, 1"	2
13	45185BH	Hex Hd Caspcrew, 5/16" x 2" G5 ZP	2	27	9163200	Locknut, 1"	2
14	50054388	Pin, Pivot 1" x 7.25"	3	28	50031212	Reflector, Amber	2

AXLES & RELATED PARTS (WINGS)

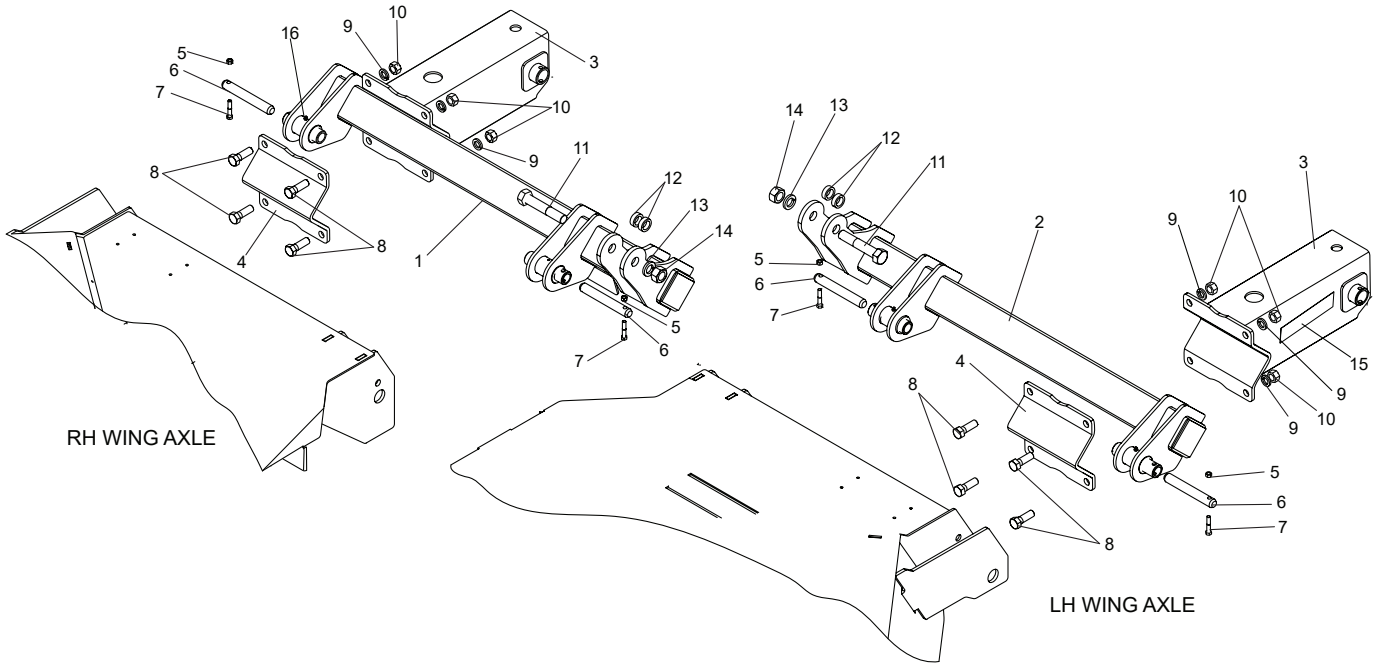

Item No.	Part No.	Description	Qty.
1	50083801	RH Wing Axle Weldment	1
2	50083800	LH Wing Axle Weldment	1
3	50083140	Axle Stub Weldment	2
4	50083288	Axle Mount Plate	2
5	20363	Locknut, 3/8" CP Center	4
6	50054388	Pivot Pin, 1" x 7.25"	4
7	1161220	Hex Hd Capscrew, 3/8" x 2" G5 ZP	4
8	20176	Hex Hd Capscrew, 3/4" x 2-1/4" G8 ZP	8
9	146	Lockwasher, 3/4" ZP	8
10	19517	Hex Nut, 3/4" CP	8
11	19137	Hex Hd Capscrew, 1" x 5-1/2" G5 ZP	2
12	50045257	Spacer, .47	4
13	15821	Lockwasher, 1" CP	2
14	9163200	Locknut, 1" Gr. C CP	2
15	50031212	Reflector, Amber	2
16	449BH	Fitting, Grease	4

AXLE ARMS & RELATED PARTS

SINGLE SPINDLE (WINGS)

DUAL SPINDLE (CENTER & WINGS)

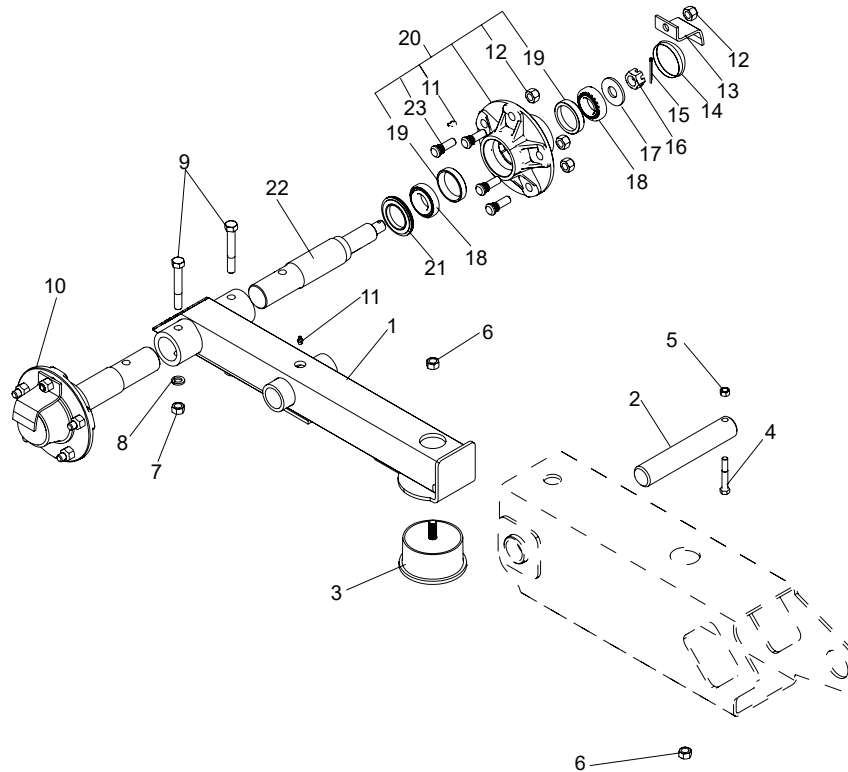

Item No.	Part No.	Description	Qty.	NOTES
	50083399	LH Axle Assy.	1	
	50083400	RH Axle Assy	1	
	50083401	Dual Axle Assy	1	
1	50083398	Tube Weldment	1	
2	50081370	Pivot Pin, 1.50" x 8.40"	1	
3	50083305	Axle Isolator	1	
4	20224	Hex Hd Capscrew, 3/8" x 2-1/2" G5 ZP	1	
5	20363	Locknut, 3/8" CP Center	1	
6	45213BH	Locknut, 1/2" GR. G NF	2	
7	15554	Locknut, 1/2" CP	A/R	1 - Spindle, 2 - Dual
8	15806	Lockwasher, 1/2" CP	A/R	1 - Spindle, 2 - Dual
9	20779	Hex Hd Capscrew, 1/2" 3-1/2" G5 ZP	A/R	1 - Spindle, 2 - Dual
10	50073131	Spindle w/Hub Assy	A/R	1 - Spindle, 2 - Dual
11	449BH	Fitting, Grease	A/R	2 - Spindle, 3 - Dual
12	15515BH	Lug Nut	A/R	5 - Spindle, 10 - Dual
13	00779390	Retainer, Hub Cap	A/R	1 - Spindle, 2 - Dual
14	14-6-243	Cap, Grease	A/R	1 - Spindle, 2 - Dual
15	296	Pin, Cotter 1/8" x 1-1/2"	A/R	1 - Spindle, 2 - Dual
16	120BH	Slotted Hex Nut, 3/4" NF CP	A/R	1 - Spindle, 2 - Dual
17	15920	Flatwasher, 3/4" ZP	A/R	1 - Spindle, 2 - Dual
18	50076BH	Bearing Cup	A/R	2 - Spindle, 4 - Dual
19	14-6-197	Bearing Cup	A/R	2 - Spindle, 4 - Dual
20	50035740	Hub Assy.	A/R	1 - Spindle, 2 - Dual
21	7967	Seal, Triple Lip	A/R	1 - Spindle, 2 - Dual
22	50073119	Spindle	A/R	1 - Spindle, 2 - Dual
23	15445	Lug Bolt	A/R	5 - Spindle, 10 - Dual

TANDEM AXLE ARMS & RELATED PARTS (CENTER & WINGS)

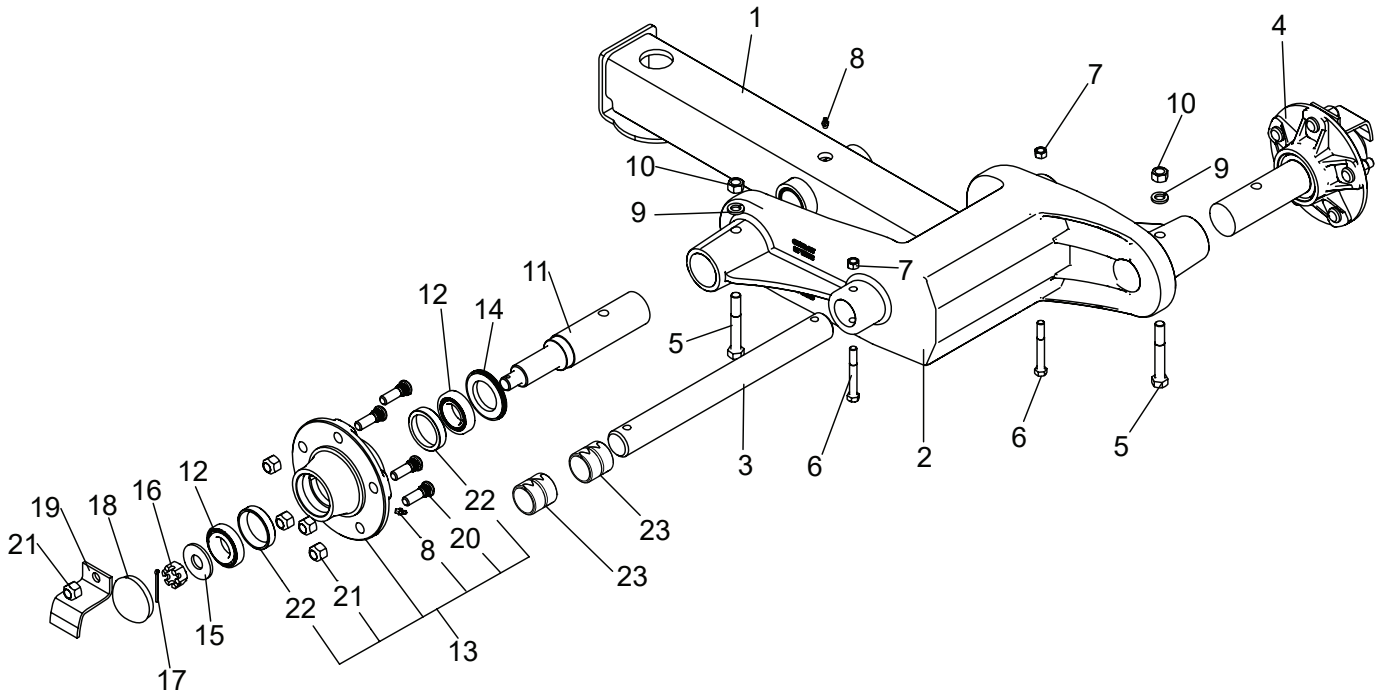

Item No.	Part No.	Description	Qty.	Item No.	Part No.	Description	Qty.
	50083502	A Size Tandem Axle Assy (LH)	1	12	50076BH	Roller Bearing Cone	4
	50083503	B Size Tandem Axle Assy (RH)	1	13	50035740	Hub Assy	2
1	50083492	Tandem Tube Weldment	1	14	7967	Seal, Triple Lip	2
2	50083378	Universal Tandem Casting	1	15	15920	Flatwasher, 3/4" ZP	2
3	50083450	Pivot Pin, 1.50" x 15.375"	1	16	120BH	Slotted Hex Nut, 3/4" NF ZP	2
4	50073145	Spindle w/Hub Assy	2	17	296	Cotter Pin, 1/8" x 1-1/2"	2
5	20779	Hex Hd Capscrew, 1/2" x 3-1/2" G5 ZP	2	18	14-6-243	Cap, Grease	2
6	19055	Hex Hd Capscrew, 3/8" x 3" G5 ZP	2	19	00779390	Retainer, Hub Cap	2
7	20363	Locknut, 3/8" CP	2	20	15445	Hub Bolt, 1/2" - 20 UNF	10
8	449BH	Fitting, Grease	4	21	15515BH	Hex Nut, Beveled 45°	10
9	15806	Lockwasher, 1/2" CP	2	22	14-6-197	Bearing Cup	4
10	15554	Locknut, 1/2" CP	2	23	50083488	Spring Bushing 1-1/2" w/Grease Groove	2
11	50041170	Tandem Spindle, Short	2				

WHEEL AND TIRE ASSEMBLIES

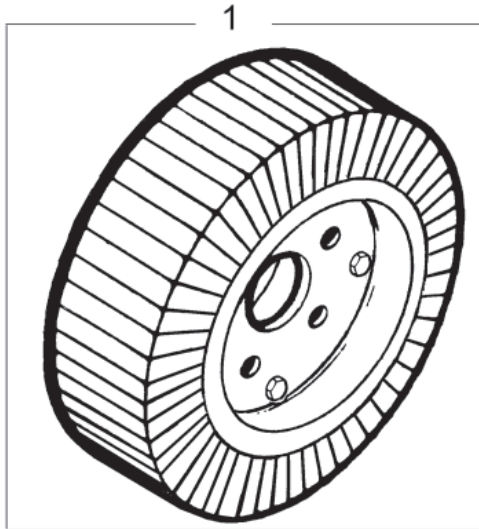

294SP SOLID TIRE ASSEMBLY 20" DIAMETER

Item No.	Part No.	Description	Qty.
1	294SP	Solid Tire Assembly,	1

50075401SP TIRE ASSEMBLY 25" Diameter

Item No.	Part No.	Description	Qty.
1	50075401SP	Segmented Tire Assembly	1

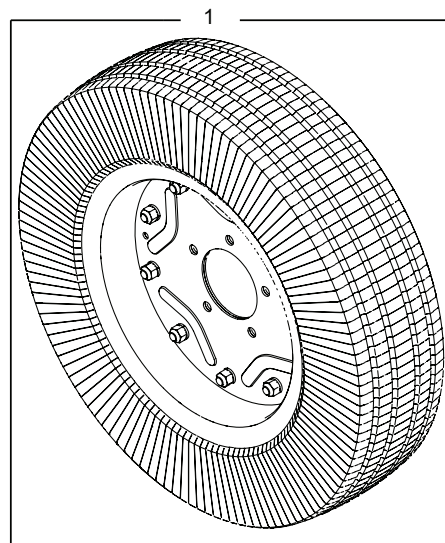

50072403SP AIR FILLED AIRPLANE TIRE ASSEMBLY 24 PLY 27.5" x 8.75" - 14.5"

Item No.	Part No.	Description	Qty.
1	50072403SP	Air Filled Tire Assembly 27.5" x 8.75" - 14.5"	1

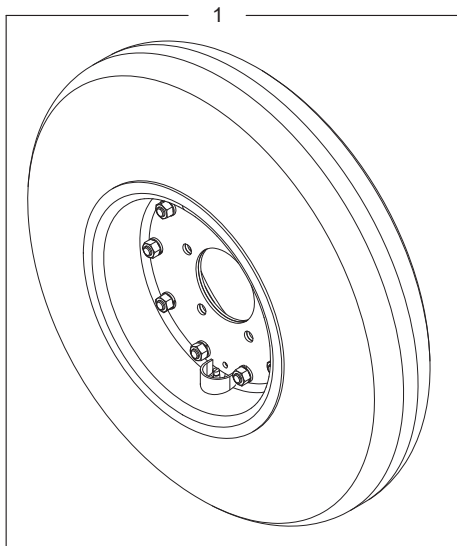

WHEEL AND TIRE ASSEMBLIES

50050727SP AIRPLANE TIRE ASSEMBLY

Item No.	Part No.	Description	Qty.
1	50051233BH	Tire, 29 x 9.0 - 15/16 Ply	1
2	50051234	Tube 9 x 15	1
3	50073233	Wheel Flange Set	1
4	20054	Capscrew, 1/2" x 1" G5 ZP	10
5	15804	Lockwasher, 1/2"	10
6	15508	Hex Nut, 1/2"	10
7	50050727SP	Tire Assembly	1

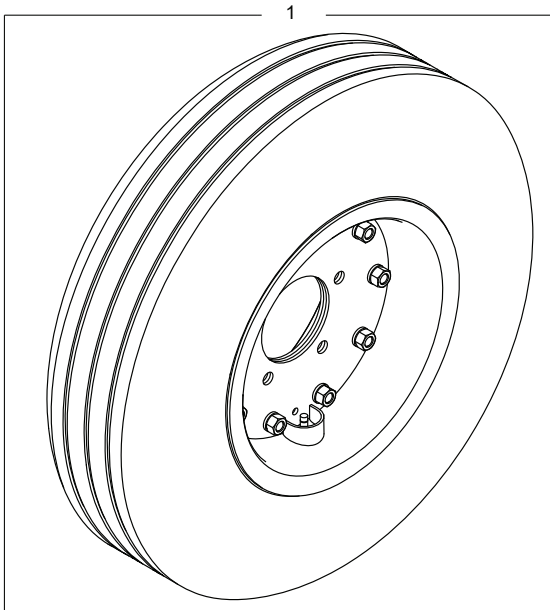
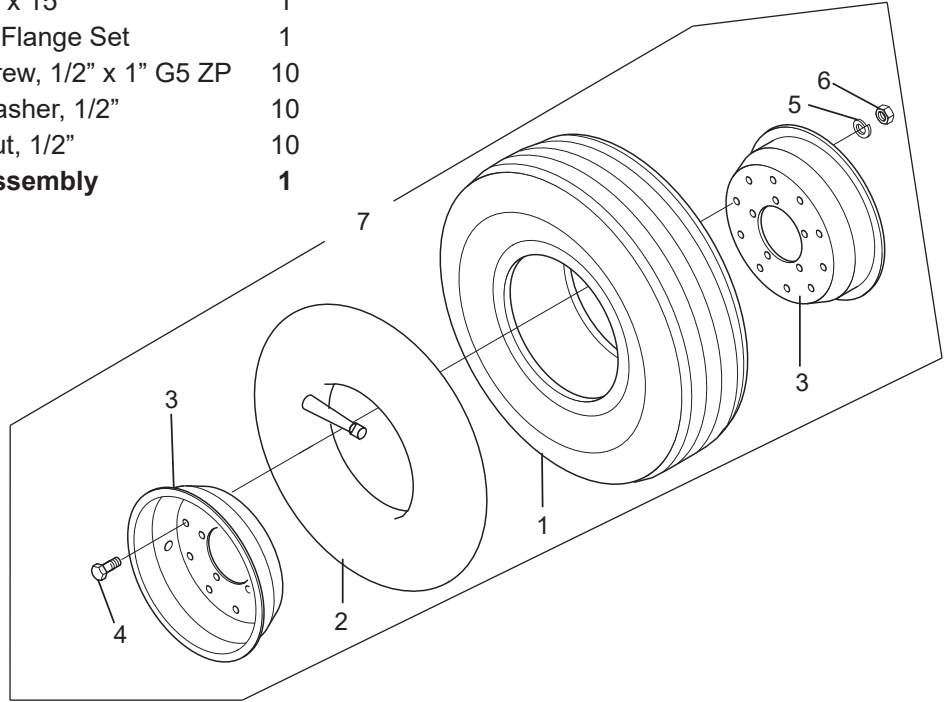

50083457SP FOAM FILLED TIRE ASSEMBLY 25.5" x 8" - 14"

Item No.	Part No.	Description	Qty.
1	50083457SP	Foam Filled Tire Assembly 25.5" x 8" - 14"	1

GAUGE WHEEL KIT - OPTIONAL

50084089 - LH GAUGE WHEEL KIT

50084090 - RH GAUGE WHEEL KIT

This Part Listing applies to
RH & LH Gauge Wheel Kit

LH GAUGE WHEEL KIT SHOWN

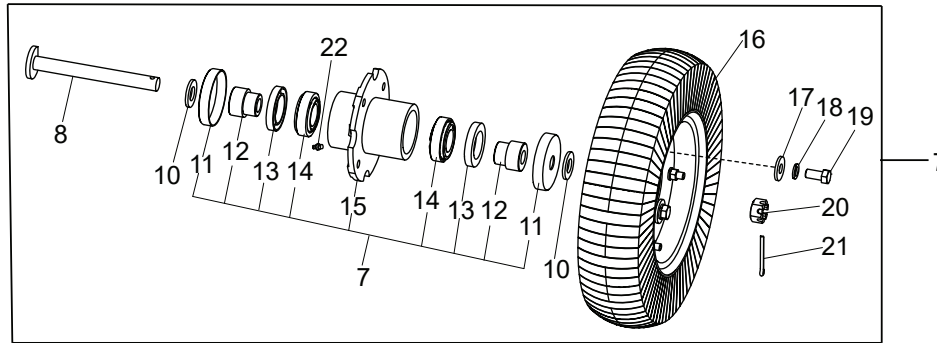
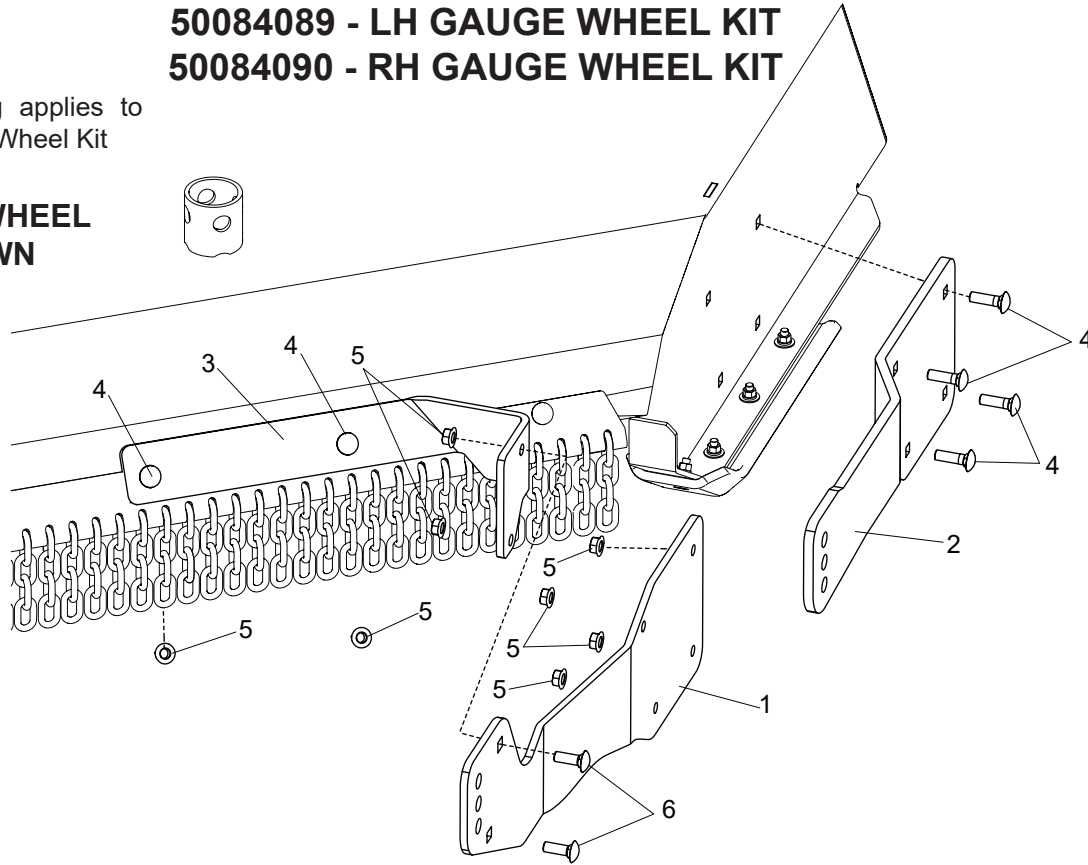

Item No.	Part No.	Description	Qty.	Item No.	Part No.	Description	Qty.
1	50084097	Gauge Wheel Mount, Inside LH	1	11	50068520	Protective Cap	2
	50084096	Gauge Wheel Mount, Inside RH	1	12	50068523	Bushing	2
2	50084094	Gauge Wheel Sideband Mount, LH	1	13	50068525	Seal	2
	50084093	Gauge Wheel Sideband Mount, RH	1	14	50068521	Bearing, Roller 31.5 x 62 x 19	2
3	50084100	Gauge Wheel Face Mount, LH	1	15	50068522	Hub Casting	1
	50084099	Gauge Wheel Face Mount, RH	1	16	500BH	Wheel Assy W/Solid Tire	1
4	44134BH	Carriage Bolts, 1/2" x 1-3/4" G5	6	17	44269	Flatwasher, M12 ZP	4
5	44998BH	Locknut, 1/2" CNTR. FLNG. GR	8	18	44200BH	Lockwasher, M12 ZP	1
6	5161614	Carriage Bolt, 1/2" x 1-1/2" G5 ZP	2	19	44204BH	HHCS M12 x 1.75 x 25 G8.8 ZP	1
7	50084014	Laminated Tire W/Bearing	1	20	120BH	Slit. Hex Nut 3/4"	1
8	50067488	Axle Bolt	1	21	20167	Cotter Pin, 3/16 x 2" ZP	1
9	50083917	Tailwheel Hub Assy.	1	22	449BH	Fitting, Grease 1/4-28 UNF. Str.	1
10	50068524	Washer	2				

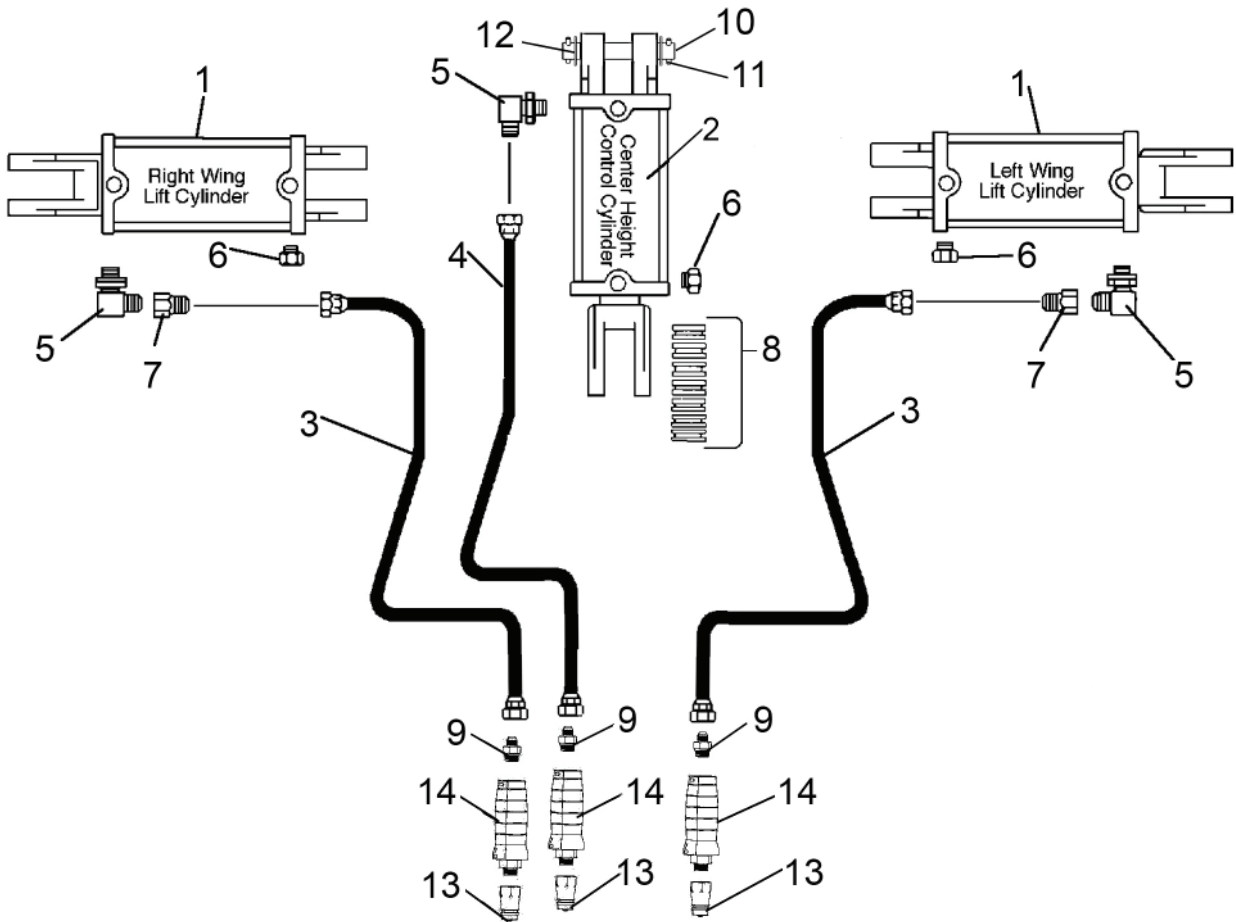

HYDRAULICS WHEN PLUMBING TO TRACTOR WITH 3 REMOTES

Item No.	Part No.	Description	Qty.
1	50081895	Hydraulic Cylinder Assy. (Wing)	2
2	50081896	Hydraulic Cylinder Assy. (Axle)	1
3	62774	Hydraulic Hose Assy, 228"	2
4	50015063	Hydraulic Hose Assy, 196"	1
5	14-40-98	Elbow 90 Degree	3
6	86500	Breather Plug	3
7	50068458	Restrictor, .078 Orifice	2
8	63451	Stop Kit	1
9	53340BH	Adaptor, 9/16 JIC to 3/4 SAE	3
10	50069414	Cylinder Pin, 6-5/8" Lg.	1
11	20167	Cotter Pin, 3/16" x 2" ZP	2
12	20376	Flatwasher, 1"	2
13	50083329	Hydraulic Quick Connect 1/2" ORB	3
14	50083328	Hydraulic Hose Handle - Gray	1
	50083327	Hydraulic Hose Handle - Red	1
	50083326	Hydraulic Hose Handle - Black	1

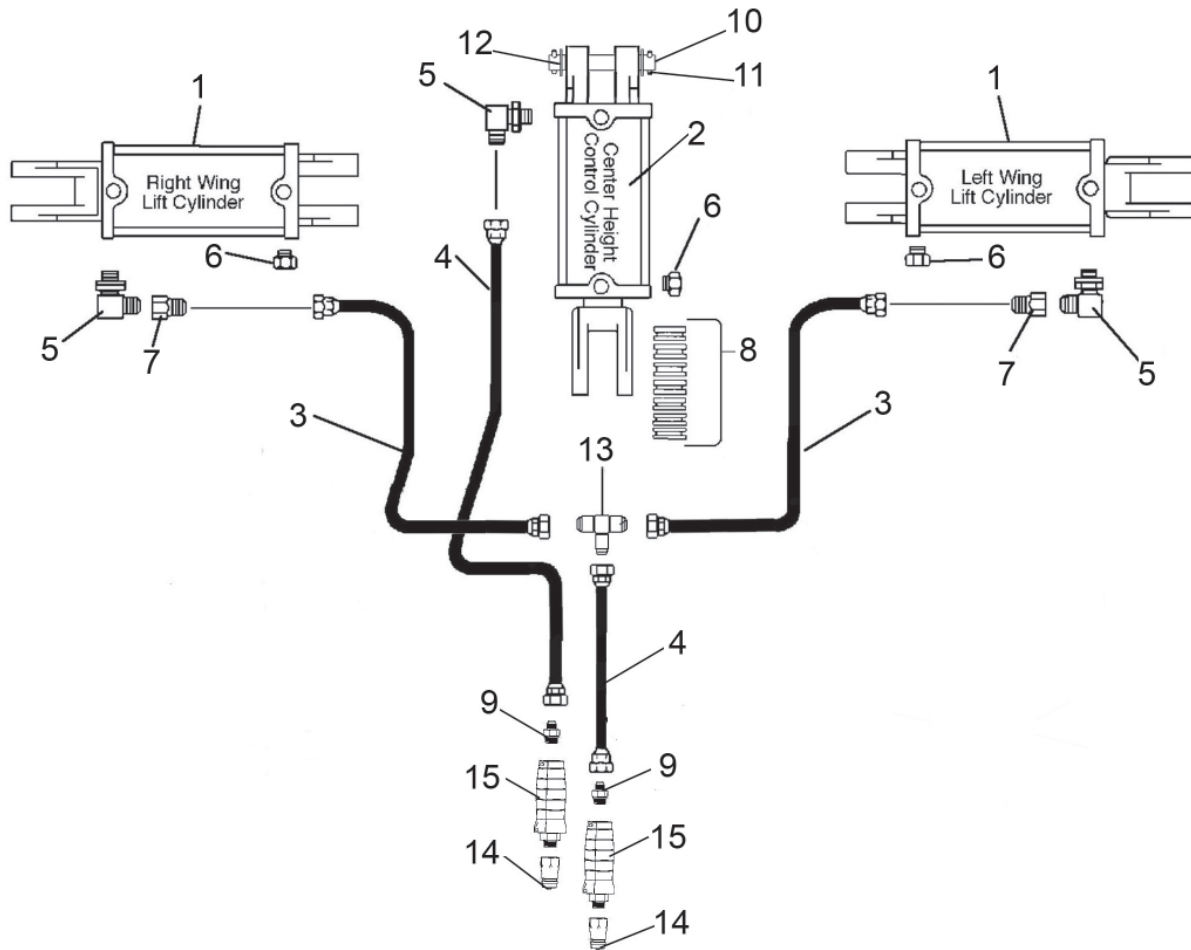

HYDRAULICS WHEN PLUMBING TO TRACTOR WITH 2 REMOTES

Item No.	Part No.	Description	Qty.
1	50081895	Hydraulic Cylinder Assy. (Wing)	2
2	50081896	Hydraulic Cylinder Assy. (Axle)	1
3	62430	Hydraulic Hose Assy, 48"	2
4	50015063	Hydraulic Hose Assy, 196"	2
5	14-40-98	Elbow 90 Degree	3
6	86500	Breather Plug	3
7	50068458	Restrictor, .078 Orifice	2
8	63451	Stop Kit	1
9	53340BH	Adaptor, 9/16 JIC to 3/4 SAE	2
10	50069414	Cylinder Pin, 6-5/8" Lg.	1
11	20167	Cotter Pin, 3/16" x 2" ZP	2
12	20376	Flatwasher, 1"	2
13	53339BH	Tee, Glare	1
14	50083329	Hydraulic Quick Connect 1/2" ORB	2
15	50083328	Hydraulic Hose Handle - Gray	1
	50083327	Hydraulic Hose Handle - Red	1
	50083326	Hydraulic Hose Handle - Black	1

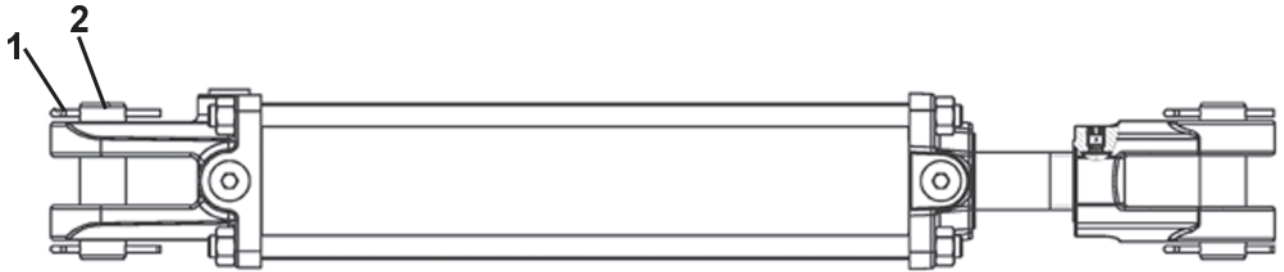

50081895
WING HYDRAULIC CYLINDER
 3" Bore X 12" Stroke X 1.25" Rod Diameter
 Manufactured by Bailey

50081896
AXLE HYDRAULIC CYLINDER
 3.50" Bore X 8" Stroke X 1.25" Rod Diameter
 Manufactured by Bailey

Item No.	Part No.	Description	Qty.
	50081895	Hydraulic Cylinder Assy.	1
1	21020614	Cotter Pin	4
2	95425	Pin, 1" Dia.	2
3	50082029	Seal Kit for 3.00 Bore (item not shown)	1

Item No.	Part No.	Description	Qty.
	50081896	Hydraulic Cylinder Assy	1
1	21020614	Cotter Pin	4
2	95425	Pin, 1" Dia.	2
3	50082030	Seal Kit for 3.50 Bore (item not shown)	1

DECAL KITS

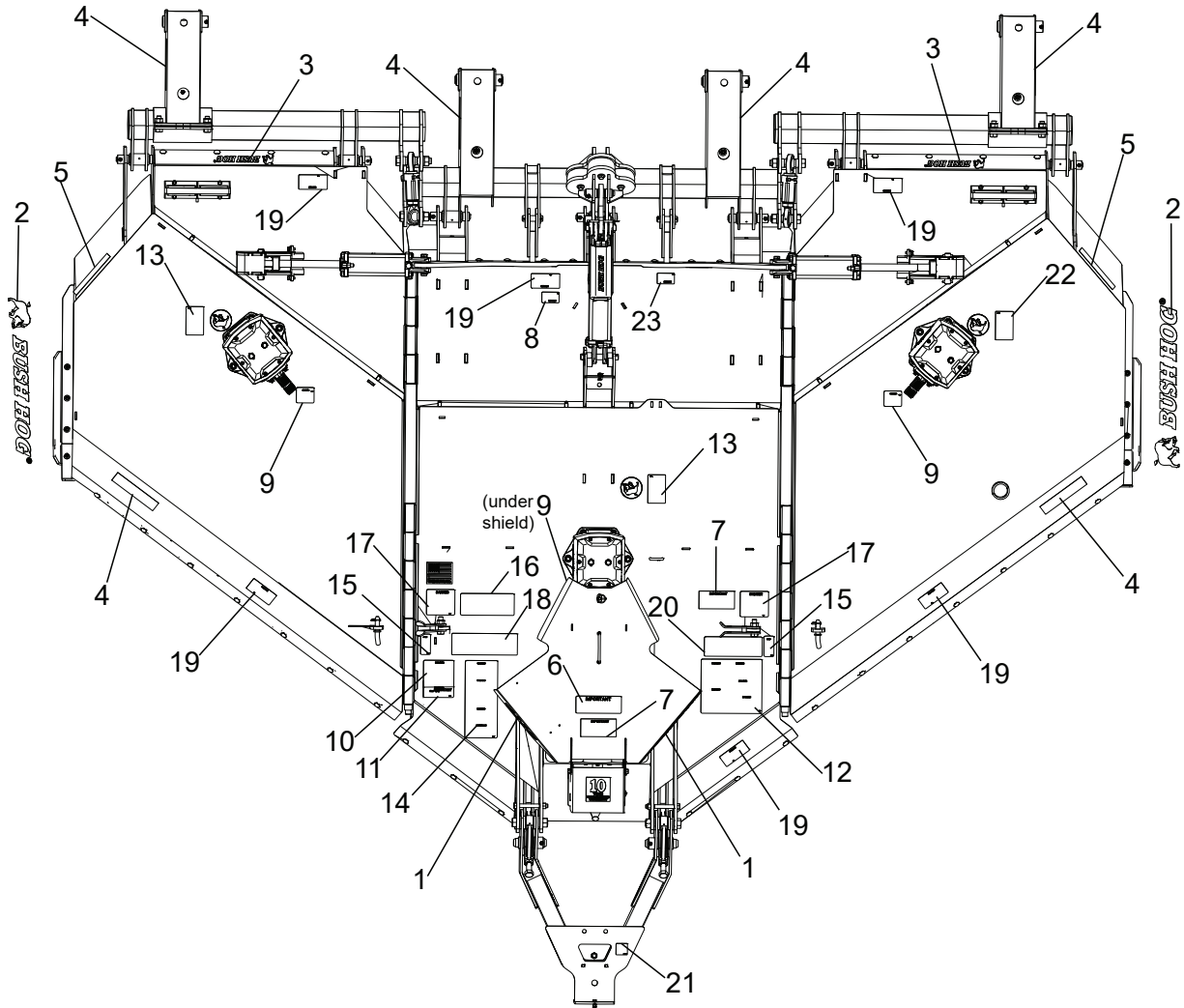

Item No.	Part No.	Description	Qty.	Item No.	Part No.	Description	Qty.
	50083831	Decal Kit for 5115/15115	1	11	D548	Decal, Warning (1000 RPM)	1
	50084170	Decal Kit for 5110/15110	1	12	D549	Decal, Danger/Operation	1
1	50083784	Decal, Model 5115	2	13	D551	Decal, Blade Rotation, CCW	2
	50083786	Decal, Model 5110	2	14	D553	Decal, Warning	1
	50083785	Decal, Model 15115	2	15	D555	Decal, Danger	2
	50083787	Decal, Model 15110	2	16	D559	Decal, Genuine BH Parts	1
2	50080370	Decal, Bush Hog Logo 4.52" x 29.70"	2	17	D565	Decal, Danger	2
3	50065309	Decal, Bush Hog Logo 2.28" x 15.00"	2	18	D587	Decal, Lubrication Chart	1
4	50031212	Reflector, Amber	6	19	D614	Decal, Danger Thrown Object	6
5	50031214	Reflector, Red	2	20	D813	Decal, Danger Multilingual	1
6	87340	Decal, Important	1	21	D1085	Decal, Notice	1
7	91443	Decal, Important	2	22	D552	Decal, Blade Rotation CW	1
8	D544	Decal, Important	1	23	D575	Decal, Danger, Crushing Hazard	1
9	D546	Decal, Danger Missing Guard	4			(5110/15110 only)	
10	D547	Decal, Danger (540 RPM)	1				



BUSH HOG®

2501 Griffin Ave.
Selma, AL. 36703