



BUSH HOG®

100 SERIES REAR MOUNTED BLADE

Published 08/22

Part No.00786975C

OPERATOR'S MANUAL



This Operator's Manual is an integral part of the safe operation of this machine and must be maintained with the unit at all times. **READ, UNDERSTAND, and FOLLOW** the Safety and Operation Instructions contained in this manual before operating the equipment. *C01-Cover str*

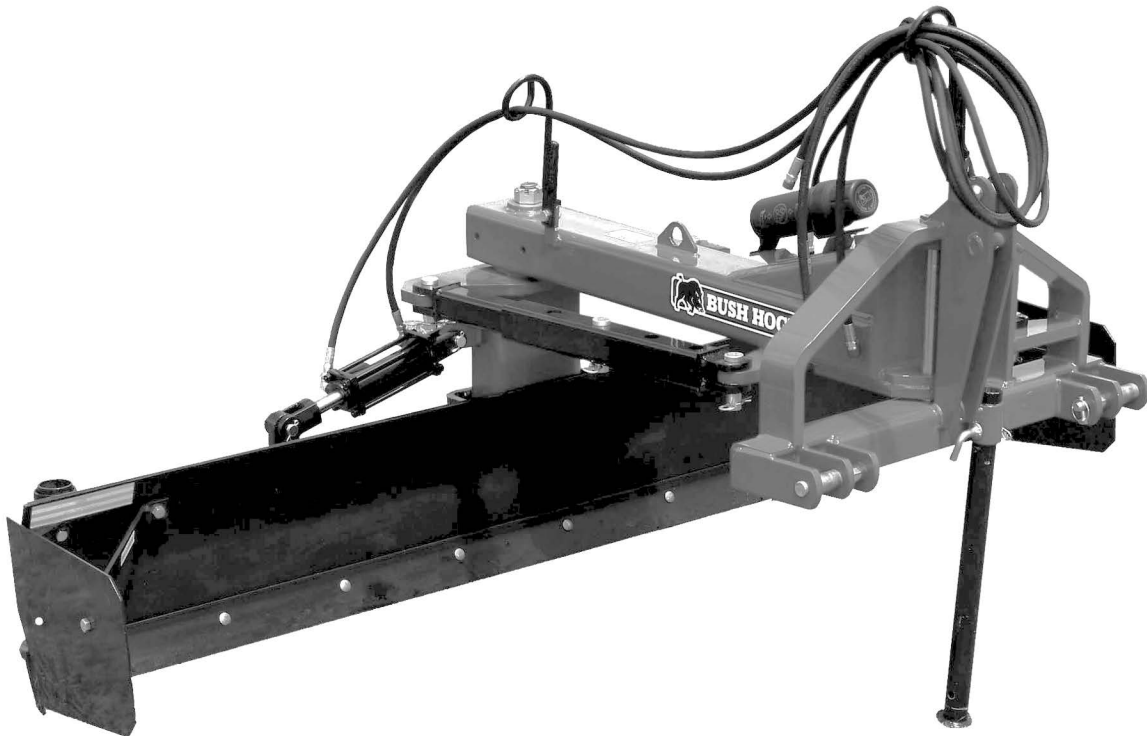

FC-BL-0002

BUSH HOG®

2501 Griffin Ave.
Selma, AL 36703
334-874-2700
www.bushhog.com

Bush Hog Web Page



www.algqr.com/bwe

¡ATENCIÓN!
LEA EL INSTRUCTIVO



Si No Lee Ingles, Pida
Ayuda a Alguien
Que Se Lo Lea Para Que le
Traduzca Las
Medidas de Seguridad

**A™ MEMBER OF THE
ALAMO GROUP**
ALWAYS ON THE CUTTING EDGE®

©2022 Alamo Group Inc.

To the Owner/Operator/Dealer

All implements with moving parts are potentially hazardous. There is no substitute for a cautious, safe-minded operator who recognizes the potential hazards and follows reasonable safety practices. The manufacturer has designed this implement to be used with all its safety equipment properly attached to minimize the chance of accidents.

BEFORE YOU START! Read the safety messages on the implement and shown in your manual. Observe the rules of safety and common sense!

WARNING

TO AVOID SERIOUS INJURY OR DEATH:

1. READ AND UNDERSTAND OPERATOR'S MANUAL.
2. TRACTOR MUST BE EQUIPPED WITH ROLL-OVER PROTECTION (ROPS) AND SWAY CHAINS.
3. ALWAYS WEAR SAFETY GLASSES, SAFETY SHOES AND SEAT BELT FASTENED TIGHTLY.
4. STOP TRACTOR, LOCK BRAKES, AND BLOCK UP OR SUPPORT IMPLEMENT SECURELY BEFORE WORKING UNDER RAISED COMPONENTS.
5. ALLOW NO RIDERS AT ANY TIME ON TRACTOR OR IMPLEMENT. FALLING OFF CAN KILL.
6. KEEP BYSTANDERS CLEAR OF MOVING PARTS AND WORKING AREA. KEEP CHILDREN AWAY!
7. DO NOT LIFT, LOWER, OR OPERATE UNLESS EVERYONE IS CLEAR OF IMPLEMENT.
8. USE INCREASED CAUTION ON SLOPES & NEAR BANKS AND DITCHES TO PREVENT OVERTURN.
9. LOCK LIFT LEVER UP FOR TRANSPORT. HAVE SMV SIGN VISIBLE. FOLLOW LOCAL LAWS.
10. USE PARKING STAND OR BLOCK UP WHEN UNHITCHING FROM TRACTOR.

999200

WARRANTY INFORMATION:

Read and understand the complete Warranty Statement found in this Manual. Fill out the Warranty Registration Form in full and return it to within 30 Days. Make certain the Serial Number of the Machine is recorded on the Warranty Card and on the Warranty Form that you retain.

Table of Contents

SAFETY SECTION	1 - 1
SAFETY MESSAGES	1 - 2
PARTS INFORMATION	1 - 8
DECAL LOCATION	1 - 9
DECAL DESCRIPTION	1 - 11
FEDERAL LAWS AND REGULATIONS	1 - 14
INTRODUCTION SECTION	2 - 1
ATTENTION OWNER/OPERATOR	2 - 4
BUSH HOG LIMITED WARRANTY	2 - 5
ASSEMBLY SECTION	3 - 1
Planer Wheel	3 - 3
Operation - Special Notice	3 - 3
Gauge Wheel (Extra Equipment)	3 - 5
Skid Shoes & Quick Tack End Plates (Extra Equipment)	3 - 5
HYDRAULIC SYSTEM	3 - 6
Selector Valve (Accessory Equipment)	3 - 6
HYDRAULIC CONTROL VALVE (ACCESSORY EQUIPMENT)	3 - 7
OPERATION SECTION	4 - 1
STANDARD EQUIPMENT AND SPECIFICATIONS	4 - 3
OPERATOR REQUIREMENTS	4 - 4
TRACTOR REQUIREMENTS	4 - 5
ROPS and Seat Belt	4 - 5
Tractor Horsepower	4 - 5
Tractor 3-Point Hitch	4 - 6
Front End Weight	4 - 6
GETTING ON AND OFF THE TRACTOR	4 - 7
Boarding the Tractor	4 - 7
Dismounting the Tractor	4 - 7
STARTING THE TRACTOR	4 - 8
CONNECTING THE REAR BLADE TO THE TRACTOR	4 - 9
Connecting the Rear Blade	4 - 9
PRE-OPERATION INSPECTION AND SERVICE	4 - 10
Tractor Pre-Operation Inspection/Service	4 - 10
Blade Pre-Operation Inspection/Service	4 - 11
BLADE & BOX BLADE PRE-OPERATION INSPECTION	4 - 12
TRACTOR PRE-OPERATION INSPECTION	4 - 13
DRIVING THE TRACTOR AND IMPLEMENT	4 - 14
Starting the Tractor	4 - 15
Brake and Differential Lock Setting	4 - 15
Driving the Tractor and Blade	4 - 16
OPERATING THE TRACTOR AND IMPLEMENT	4 - 16
Operating the Blade	4 - 16

Table of Contents

Shutting Down the Implement	4 - 17
DISCONNECTING THE BLADE FROM THE TRACTOR.....	4 - 17
BLADE STORAGE.....	4 - 18
TRANSPORTING THE TRACTOR AND IMPLEMENT	4 - 19
TRANSPORTING ON PUBLIC ROADWAYS	4 - 19
Hauling the Tractor and Implement	4 - 21
TROUBLESHOOTING GUIDE	4 - 23
MAINTENANCE SECTION	5 - 1
PROPER TORQUE FOR FASTENERS	5 - 2

SAFETY SECTION

Safety Section 1-1

SAFETY

SAFETY MESSAGES

A careful operator is the best operator. Safety is of primary importance to the manufacturer and should be to the owner/operator. Most accidents can be avoided by being aware of your equipment, your surroundings, and observing certain precautions. The first section of this manual includes a list of Safety Messages that, if followed, will help protect the operator and bystanders from injury or death. Read and understand these Safety Messages before assembling, operating or servicing this Implement. This equipment should only be operated by those persons who have read the manual, who are responsible and trained, and who know how to do so responsibly.



The Safety Alert Symbol combined with a Signal Word, as seen below, is used throughout this manual and on decals which are attached to the equipment. The Safety Alert Symbol means: "ATTENTION! BECOME ALERT! YOUR SAFETY IS INVOLVED!" The Symbol and Signal Word are intended to warn the owner/operator of impending hazards and the degree of possible injury faced when operating this equipment.

Practice all usual and customary safe working precautions and above all--remember safety is up to YOU. Only YOU can prevent serious injury or death from unsafe practices.



Indicates an imminently hazardous situation that, if not avoided, WILL result in DEATH OR VERY SERIOUS INJURY.



Indicates an imminently hazardous situation that, if not avoided, COULD result in DEATH OR SERIOUS INJURY.



Indicates an imminently hazardous situation that, if not avoided, MAY result in MINOR INJURY.

Important

Identifies special instructions or procedures that, if not strictly observed, could result in damage to, or destruction of the machine, attachments or the environment.

NOTE: *Identifies points of particular interest for more efficient and convenient operation or repair.* (SG-1) str

READ, UNDERSTAND, and FOLLOW the following Safety Messages. Death or serious injury may occur unless care is taken to follow the warnings and instructions stated in the Safety Messages. Always use good common sense to avoid hazards. (SG-2) str



Si no lee ingles, pida ayuda a alguien que si lo lea para que le traduzca las medidas de seguridad. (SG-3) str

¡ LEA EL INSTRUCTIVO!



SAFETY

⚠ DANGER

Never operate the Tractor or Implement until you have read and completely understand this Manual, the Tractor Operator's Manual, and each of the Safety Messages found in the Manual or on the Tractor and Implement. Learn how to stop the tractor engine suddenly in an emergency. Never allow inexperienced or untrained personnel to operate the Tractor or Implement without supervision. Make sure the operator has fully read and understood the manuals prior to operation.

(SG-4)str



⚠ WARNING

Always maintain the safety signs in good readable condition. If the safety signs are missing, damaged, or unreadable, obtain and install replacement safety signs immediately. (SG-5)str

⚠ WARNING

Make certain that the "Slow Moving Vehicle" (SMV) sign is installed in such a way as to be clearly visible and legible. When transporting the Equipment use the Tractor flashing warning lights and follow all local traffic regulations. (SG-6)str

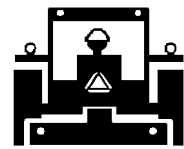

⚠ WARNING

Operate this Equipment only with a Tractor equipped with an approved roll-over-protective system (ROPS). Always wear seat belts. Death or serious injury could result from falling off the tractor, particularly during a turnover when the operator could be pinned under the ROPS. (SG-7) str



⚠ WARNING

Do not modify or alter this Implement. Do not permit anyone to modify or alter this Implement, any of its components or any Implement function. (SG-8)str

⚠ DANGER

BEFORE leaving the tractor seat lower the implement, set the parking brake and/or set the tractor transmission in parking gear, disengage the PTO, stop the engine, remove the key, and wait for all moving parts to stop. Place the tractor shift lever into a low range or parking gear to prevent the tractor from rolling. Never dismount a Tractor that is moving or while the engine is running. Operate the Tractor controls from the tractor seat only.

(SG-9)str

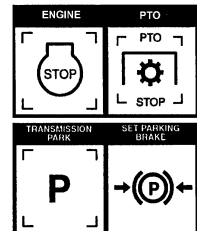

⚠ DANGER

Never allow children or other persons to ride on the Tractor or Implement. Falling off can result in death or serious injury. (SG-10)str



⚠ DANGER

Never allow children to operate, ride on, or come close to the Tractor or Implement. Usually, 16-17 year-old children who are mature and responsible can operate the implement with adult supervision, if they have read and understand the Operator's Manuals, been trained in proper operation of the tractor and Implement, and are physically large enough to reach and operate the controls easily. (SG-11) str



SAFETY

SAFETY

WARNING

Do not mount or dismount the Tractor while the tractor is moving. Mount the Tractor only when the Tractor and all moving parts are completely stopped. Dismounting a moving power unit can result in a crushing hazard that can cause death or serious injury. (SG-12) str



DANGER

Start tractor only when properly seated in the Tractor seat. Starting a tractor in gear can result in death or serious injury. Read the Tractor operators manual for proper starting instructions. (SG-13) str



DANGER

Never work under the Implement, the framework, or any lifted component unless the Implement is securely supported or blocked up to prevent sudden or inadvertent falling which could cause death or serious injury. (SG-14)str



WARNING

Do not operate this Equipment with hydraulic oil or fuel leaking. Oil and fuel are explosive and their presence could present a hazard. Do not check for leaks with your hand! High-pressure oil streams from breaks in the line could penetrate the skin and cause tissue damage including gangrene. To check for a hose leak, SHUT the unit ENGINE OFF and remove all hydraulic pressure. Wear oil impenetrable gloves, safety glasses and use cardboard to check for evidence of oil leaks. If you suspect a leak, REMOVE the HOSE and have it tested at a Dealer. If oil does penetrate the skin, have the injury treated immediately by a physician knowledgeable and skilled in this procedure. (SG-15) str



WARNING

The operator and all support personnel should wear hard hats, safety shoes, safety glasses, and proper hearing protection at all times for protection from injury including injury from items that may be thrown by the equipment. (SG-16)str

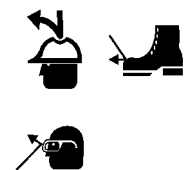

SAFETY

CAUTION

PROLONGED EXPOSURE TO LOUD NOISE MAY CAUSE PERMANENT HEARING LOSS! Tractors with or without an Implement attached can often be noisy enough to cause permanent hearing loss. We recommend that you always wear hearing protection if the noise in the Operator's position exceeds 80db. Noise over 85db over an extended period of time will cause severe hearing loss. Noise over 90db adjacent to the Operator over an extended period of time will cause permanent or total hearing loss.

NOTE: *Hearing loss from loud noise [from tractors, chain saws, radios, and other such sources close to the ear] is cumulative over a lifetime without hope of natural recovery.* (SG-17)str



WARNING

Transport only at speeds where you can maintain control of the equipment. Serious accidents and injuries can result from operating this equipment at high speeds. Understand the Tractor and Implement and how it handles before transporting on streets and highways. Make sure the Tractor steering and brakes are in good condition and operate properly.

Before transporting the Tractor and Implement, determine the proper transport speeds for you and the equipment. Make sure you abide by the following rules:

Test the tractor at a slow speed and increase the speed slowly. Apply the Brakes smoothly to determine the stopping characteristics of the Tractor and Implement. As you increase the speed of the Tractor the stopping distance increases. Determine the maximum transport speed not to exceed 20 mph (30 kph) for transporting this equipment.

Test the equipment at a slow speed in turns. Increase the speed through the turn only after you determine that the equipment can be operated at a higher speed. Use extreme care and reduce your speed when turning sharply to prevent the tractor and implement from turning over. Determine the maximum turning speed for you and this equipment before operating on roads or uneven ground.

Only transport the Tractor and Implement at the speeds which allow you to properly control the equipment.

Be aware of the operating conditions. Do not operate the Tractor with weak or faulty brakes or worn tires. When operating down a hill or on wet or rain slick roads, the braking distance increases: use extreme care and reduce your speed. When operating in traffic always use the Tractor's flashing warning lights and reduce your speed. Be aware of traffic around you and watch out for the other guy. (SG-19)str



SAFETY

WARNING

Never attempt to lubricate, adjust, or remove material from the Implement while it is in motion or while tractor engine is running. (SG-20)str

SAFETY

SAFETY

⚠ WARNING

Periodically inspect all moving parts for wear and replace when necessary with authorized service parts. Look for loose fasteners, worn or broken parts, and leaky or loose fittings. Make sure all pins have cotter pins and washers. Serious injury may occur from not maintaining this machine in good working order. (SG-21)str



⚠ WARNING

Always read carefully and comply fully with the manufacturer's instructions when handling oil, solvents, cleansers, and any other chemical agent. (SG-22)str



⚠ DANGER

Never run the Tractor engine in a closed building or without adequate ventilation. The exhaust fumes can be hazardous to your health. (SG-23) str

⚠ DANGER

KEEP AWAY FROM ROTATING ELEMENTS to prevent entanglement and possible death or serious injury. (SG-24)str



⚠ DANGER

Never allow children to play on or around Tractor or Implement. Children can slip or fall off the Equipment and be killed or injured. Inadvertent contact with controls can cause the Implement to shift or fall crushing themselves or others. (SG-25) str

⚠ DANGER

DO NOT use drugs or alcohol immediately before or while operating the Tractor and Implement. Drugs and alcohol will affect an operator's alertness and coordination and therefore affect the operator's ability to operate the equipment safely. Before operating the Tractor or Implement, an operator on prescription or over-the-counter medication must consult a medical professional regarding any side effects of the medication that would hinder their ability to operate the Equipment safely. NEVER knowingly allow anyone to operate this equipment when their alertness or coordination is impaired. Serious injury or death to the operator or others could result if the operator is under the influence of drugs or alcohol. (SG-27) str



⚠ DANGER

Operate the Tractor and/or Implement controls only while properly seated in the Tractor seat with the seat belt securely fastened around you. Inadvertent movement of the Tractor or Implement may cause death or serious injury. (SG-29)str

SAFETY

WARNING

Be particularly careful when transporting the Implement with the Tractor. Turn curves or go up hills only at a low speed and using a gradual steering angle. Rear mounted implements move the center of gravity to the rear and remove weight from the front wheels. Make certain, by adding front ballast, that at least 20% of the tractor's weight is on the front wheels to prevent rearing up, loss of steering control or Tractor tip-over. Slow down on rough or uneven surfaces to prevent loss of steering control which could result in property damage or possible injury. Do not transport unless 3-Point lift lever is fully raised and in the latched transport position. Dropping implement in transport can cause serious damage to the tractor and/or Implement and possibly cause the operator or others to be killed or injured. (S3PT-02)str

WARNING

Relieve hydraulic pressure prior to doing any maintenance or repair work on the Implement. Place the Implement on the ground or securely blocked up, disengage the PTO, and turn off the tractor engine. Push and pull the Remote Cylinder lever in and out several times prior to starting any maintenance or repair work. (S3PT-09)str



DANGER

This Implement may be wider than the Tractor. Be careful when operating or transporting this equipment to prevent the Implement from running into or striking sign posts, guard rails, concrete abutments or other solid objects. Such an impact could cause the Implement and Tractor to pivot violently resulting in loss of steering control, death, or serious injury. Never allow the Implement to contact obstacles. (S3PT-12)str

DANGER

There are obvious and hidden potential hazards in operating Rear Blades and Box Scrapers as in all power-driven equipment. REMEMBER! This machine is often operated in rough terrain conditions that include gullies, holes, slopes, hidden obstructions and the like. Death or serious injury may occur unless care is taken to assure the personal safety of the operator and bystanders in the area. (SBL-1)str

DANGER

NEVER PARK BLADE ON THE BACK OF THE MOLDBOARD. Inadvertent falling could cause death or serious injury. ALWAYS LOWER HITCH onto stand or onto secure blocks. (SBL-2)str

WARNING

Keep fingers clear of adjusting holes. A sudden movement could cause injury or even amputate fingers. KEEP CHILDREN AWAY WHEN MAKING ADJUSTMENTS. (SBL-3)str

DANGER

Never leave blade unattended in the lifted position. Accidental operation of lifting lever or a hydraulic failure may cause sudden drop of unit with subsequent death or injury by crushing. Lower Stand and pin in place, or put a secure support under the A-Frame. Lower Blade carefully to the ground. Do not put hands or feet under lifted components. (SBL-4)str

WARNING

Rear Blades can fall down if not properly supported. Always use the stand on the front hitch or block up securely to prevent falling and possible crushing injury and/or back injury from lifting heavy components. (SBL-5)str

WARNING

Cancer and Reproductive Harm www.P65Warnings.ca.gov

SAFETY

SAFETY

PARTS INFORMATION

Bush Hog products are designed utilizing specifically matched system components to ensure optimum equipment performance. These parts are made and tested to Bush Hog specifications. Non-genuine "will fit" parts do not consistently meet these specifications. The use of "will fit" parts may reduce equipment performance, void warranties, and present a safety hazard. Use genuine Bush Hog parts for economy and safety. (SPBH-2)str

SEE YOUR BUSH HOG DEALER

In addition to the design and configuration of this Implement, including Safety Signs and Safety Equipment, hazard control and accident prevention are dependent upon the awareness, concern, prudence, and proper training of personnel involved in the operation, transport, maintenance, and storage of the machine. Refer also to Safety Messages and operation instruction in each of the appropriate sections of the Tractor and Equipment Manuals. Pay close attention to the Safety Signs affixed to the Tractor and Equipment. (SG-18)str

SAFETY

SAFETY

DECAL LOCATION

NOTE: Bush Hog supplies safety decals on this product to promote safe operation. Damage to the decals may occur while in shipping, use, or reconditioning. Bush Hog cares about the safety of its customers, operators, and bystanders, and will replace the safety decals on this product in the field, free of charge (Some shipping and handling charges may apply). Contact your Bush Hog dealer to order replacement decals.

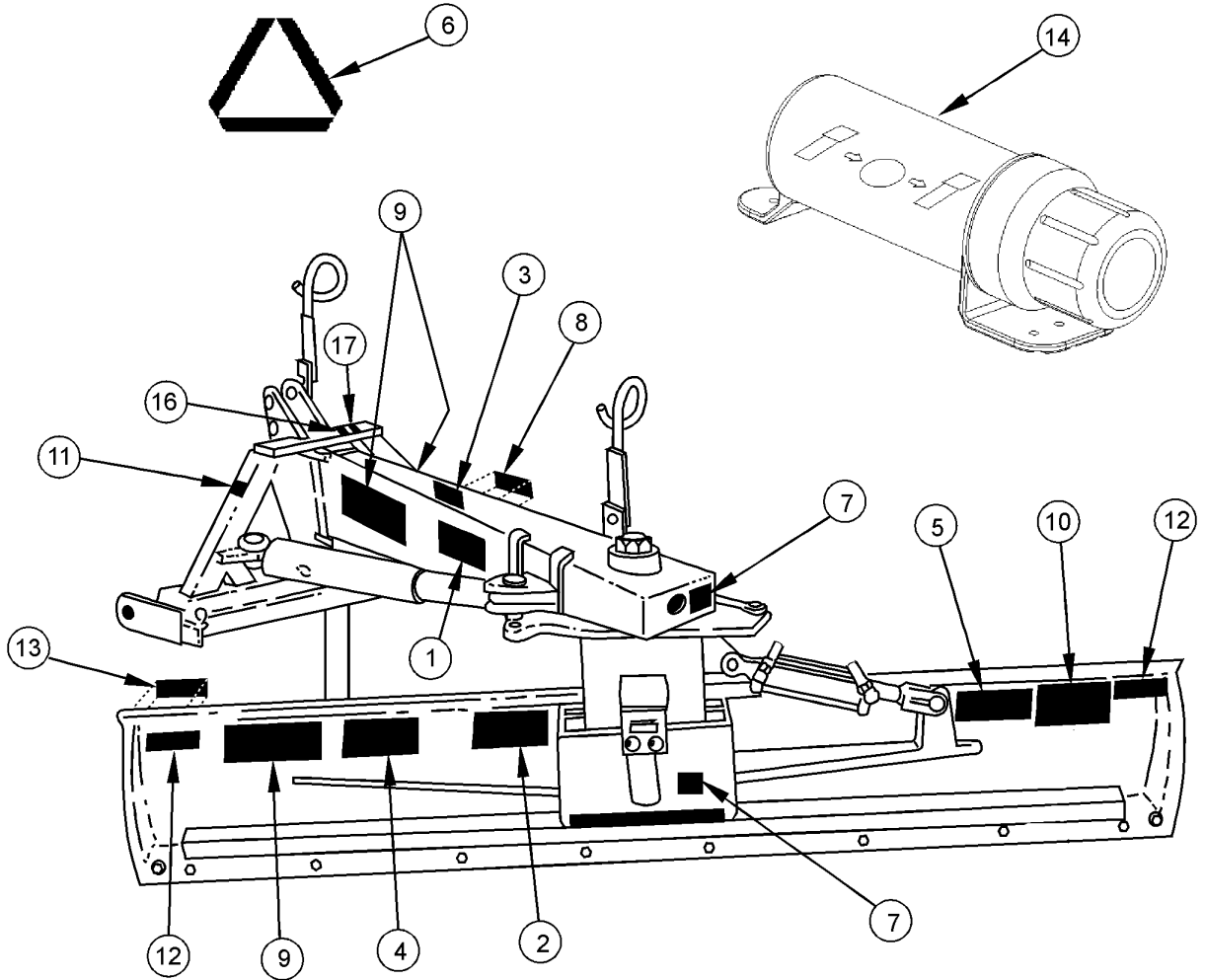

DL-BL-0022

SAFETY

SAFETY

SAFETY

ITEM	PART NO.	QTY	TYPE	DESCRIPTION
1.	00725746	1	PELIGRO	Translate Safety Material
2.	D617	1	WARNING	Oil Penetration
3.	D859	1	WARNING	Use Genuine Bush Hog Parts
4.	999000	1	WARNING	Multi-Hazard for Blades
5.	999200	1	WARNING	Multi-Hazard General
6.	03200347	1*	REFLECT	SMV Emblem
7.	000678	2	INSTRUC T	Grease Fitting Inside
8.	00763977	1	INSTRUCT	Notice To Owner
9.	00786979	1	LOGO	Bush Hog
10.	00786981	1	NAME	100-08
	00786988	1	NAME	100-09
11.	NFS	1	SERIAL PLT	Serial Number Plate
12.	1458392	2	REFLECT	Red Reflector
13.	1458393	2	REFLECT	Amber Reflector
14.	00776031	1	---	Canister, Operator's Manual
15.	00786975C	1	---	Operator's Manual
16.	999001	1	WARNING	Maintain 20% Weight
17.	D892	1	WARNING	Highway Transport

*Furnished by Tractor Manufacturer

SAFETY

SAFETY

DECAL DESCRIPTION

⚠ WARNING

TO AVOID DEATH OR SERIOUS INJURY:

- ONLY use genuine Bush Hog replacement parts, which have been validated and tested to use on Bush Hog equipment by the manufacturer.
- The equipment manufacturer cannot verify the material or structural integrity of third-party supplied non-genuine replacement parts.
- Using non-genuine parts can result in the part failing, creating hazardous conditions for operator and bystanders.

Contact local dealer or Bush Hog about repair parts at:

2501 Griffin Ave., Selma, AL 36701
Customer Service: 800-363-6096.
Email: contactus@bushhog.com www.algqr.com/bpm





⚠ WARNING

Cancer and Reproductive Harm

www.P65Warnings.ca.gov D859

⚠ WARNING

		
---	---	--

TO AVOID DEATH OR SERIOUS INJURY FROM HIGH PRESSURE HYDRAULIC OIL LEAKS PENETRATING SKIN:

- DO NOT OPERATE equipment with oil or fuel leaks.
- KEEP all hydraulic hoses, lines and connections in good condition and tight before applying system pressure.
- Relieve hydraulic pressure before disconnecting lines or working on the system.
- REMOVE and replace hose if you suspect it leaks. Have dealer test it for leaks.

HIGH PRESSURE FLUID LEAKS CAN BE INVISIBLE. WHEN CHECKING FOR HYDRAULIC LEAKS AND WORKING AROUND HYDRAULIC SYSTEMS:

- DO NOT use hands to check for leaks.
- ALWAYS WEAR safety glasses with side shields (marked to comply with ANSI Z87) and impenetrable gloves.
- USE paper or cardboard to search for leaks.
- KEEP hands and body AWAY from pin holes and nozzles ejecting hydraulic fluid.
- Hydraulic fluid may cause gangrene if not surgically removed immediately by a doctor familiar with this form of injury.

D617

SAFETY

SAFETY

WARNING

Highway Transport - Rear Blade



DO NOT transport with blade extended beyond the width of tractor. Collision with vehicles can result in death or serious injury.

- Ensure rear blade is centered behind tractor.
- Pivot moldboard 40-45° with edge closest to oncoming traffic closest to tractor.
- Ensure tractor SMV sign is visible.

See operator's manual for transporting rear blade information.

D892

WARNING

TO AVOID SERIOUS INJURY OR DEATH:

1. READ AND UNDERSTAND OPERATOR'S MANUAL.
2. TRACTOR MUST BE EQUIPPED WITH ROLL-OVER PROTECTION (ROPS) AND SWAY CHAINS.
3. ALWAYS WEAR SAFETY GLASSES, SAFETY SHOES AND SEAT BELT FASTENED TIGHTLY.
4. STOP TRACTOR, LOCK BRAKES, AND BLOCK UP OR SUPPORT IMPLEMENT SECURELY BEFORE WORKING UNDER RAISED COMPONENTS.
5. ALLOW NO RIDERS AT ANY TIME ON TRACTOR OR IMPLEMENT. FALLING OFF CAN KILL.

6. KEEP BYSTANDERS CLEAR OF MOVING PARTS AND WORKING AREA. KEEP CHILDREN AWAY!
7. DO NOT LIFT, LOWER, OR OPERATE UNLESS EVERYONE IS CLEAR OF IMPLEMENT.
8. USE INCREASED CAUTION ON SLOPES & NEAR BANKS AND DITCHES TO PREVENT OVERTURN.
9. LOCK LIFT LEVER UP FOR TRANSPORT. HAVE SMV SIGN VISIBLE. FOLLOW LOCAL LAWS.
10. USE PARKING STAND OR BLOCK UP WHEN UNHITCHING FROM TRACTOR.

999200

WARNING

1.



2.



3.



TO AVOID SERIOUS INJURY OR DEATH:

1. MAKE BLADE ADJUSTMENTS WITH TRACTOR ON LEVEL GROUND. BLADES' WEIGHT CAN SWING DOWN HILL WHEN FASTENERS ARE REMOVED AND CAUSE SERIOUS INJURY BY CRUSHING.

2. KEEP FINGERS AWAY FROM ADJUSTING HOLES TO PREVENT CRUSHING/SHEARING OFF.
3. BACK INTO PILES SLOWLY. A HIDDEN OBSTRUCTION MAY BE HIDDEN FROM VIEW.

999000

SAFETY

SAFETY

⚠ WARNING

To avoid serious injury or machine damage:

- ALWAYS MAINTAIN 20% of tractor weight on front wheels. Add weight to front if needed.
- REDUCE SPEED on inclines, in turns and in poor weather conditions.
- DO NOT lift implement while on steep slopes.
- DO NOT start or accelerate suddenly. 999001



⚠ PELIGRO

LEA EL INSTRUCTIVO

Si No Lee Ingles, Pida Ayuda a Alguien Que Si Lo Lea Para Que le Traduzca las Medidas de Seguridad.



00725746

SAFETY

FEDERAL LAWS AND REGULATIONS

This section is intended to explain in broad terms the concept and effect of federal laws and regulations concerning employer and employee equipment operators. This section is not intended as a legal interpretation of the law and should not be considered as such.

Employer-Employee Operator Regulations

U.S. Public Law 91-596 (The Williams-Steiger Occupational and Health Act of 1970) OSHA

This Act Seeks:

“...to assure so far as possible every working man and woman in the nation safe and healthful working conditions and to preserve our human resources...”

DUTIES

Sec. 5 (a) Each employer-

(1) shall furnish to each of his employees employment and a place of employment which are free from recognized hazards that are causing or are likely to cause death or serious physical harm to his employees;

(2) shall comply with occupational safety and health standards promulgated under this Act.

(b) Each employee shall comply with occupational safety and health standards and all rules, regulations and orders issued pursuant to this Act which are applicable to his own actions and conduct.

OSHA Training Requirements

Title 29, Code of Federal Regulations Part 1928.57(a)(6). www.osha.gov

Operator instructions. At the time of initial assignment and at least annually thereafter, the employer shall instruct every employee who operates an agricultural tractor and implements in the safe operating practices and servicing of equipment with which they are or will be involved, and of any other practices dictated by the work environment.

Keep all guards in place when the machine is in operation.

Permit no riders on equipment.

Stop engine, disconnect the power source, and wait for all machine movement to stop before servicing, adjusting, cleaning or unclogging the equipment, except where the machine must be running to be properly serviced or maintained, in which case the employer shall instruct employees as to all steps and procedures which are necessary to safely service or maintain the equipment.

Make sure everyone is clear of machinery before starting the engine, engaging power, or operating the machine.

Employer Responsibilities:

To ensure employee safety during Tractor and Implement operation, it is the employer's responsibility to:

1. Train the employee in the proper and safe operation of the Tractor and Implement.
2. Require that the employee read and fully understand the Tractor and Implement Operator's Manual.
3. Permit only qualified and properly trained employees to operate the Tractor and Implement.
4. Maintain the Tractor and Implement in a safe operational condition and maintain all shields and guards on the equipment.
5. Ensure the Tractor is equipped with a functional ROPS and seat belt and require that the employee operator securely fasten the safety belt and operate with the ROPS in the raised position at all times.
6. Forbid the employee operator to carry additional riders on the Tractor or Implement.
7. Provide the required tools to maintain the Tractor and Implement in a good safe working condition and provide the necessary support devices to secure the equipment safely while performing repairs and service.
8. Require that the employee operator stop operation if bystanders or passersby come within 300 feet.

Child Labor Under 16 Years of Age

Some regulations specify that no one under the age of 16 may operate power machinery. It is your responsibility to know what these regulations are in your own area or situation. (Refer to U.S. Dept. of Labor, Employment Standard Administration, Wage & Home Division, Child Labor Bulletin #102.)

INTRODUCTION SECTION

Introduction Section 2-1

INTRODUCTION

The 100 Series is designed with care and built with quality materials by skilled workers. Proper assembly, maintenance, and operating practices, as described in this manual, will help the owner/operator get years of satisfactory service from the machine.

The purpose of this manual is to familiarize, instruct. The Assembly Section instructs the owner/operator in the correct assembly of the Rear Blade using standard and optional equipment.

Careful use and timely service save extensive repairs and costly downtime losses. The Operation and Maintenance Sections of the manual train the owner/operator how to work the Blade correctly and attend to appropriate maintenance. The Trouble Shooting Guide helps diagnose difficulties with Blade and offers solution to the problems.

Safety is of primary importance to the owner/operator and to the manufacturer. The first section of this manual includes a list of Safety Messages, that, if followed, will help protect the operator and bystanders from injury or death. Many of the Safety Messages will be repeated throughout the manual. The owner/operator/dealer should know these Safety Messages before assembly and be aware of the hazards of operating this blade during assembly, use, and maintenance. The Safety Alert Symbol combined with a Signal Word, as seen below, is intended to warn the owner/operator of impending hazards and the degree of possible injury faced when operating this machine.



DANGER

Indicates a hazardous situation that, if not avoided, WILL result in DEATH OR VERY SERIOUS INJURY.



WARNING

Indicates a hazardous situation that, if not avoided, COULD result in DEATH OR SERIOUS INJURY.



CAUTION

Indicates a hazardous situation that, if not avoided, MAY result in MINOR OR MODERATE INJURY.

Important

Identifies special instructions or procedures that, if not strictly observed, could result in damage to, or destruction of the machine, attachments or the environment.

INTRODUCTION

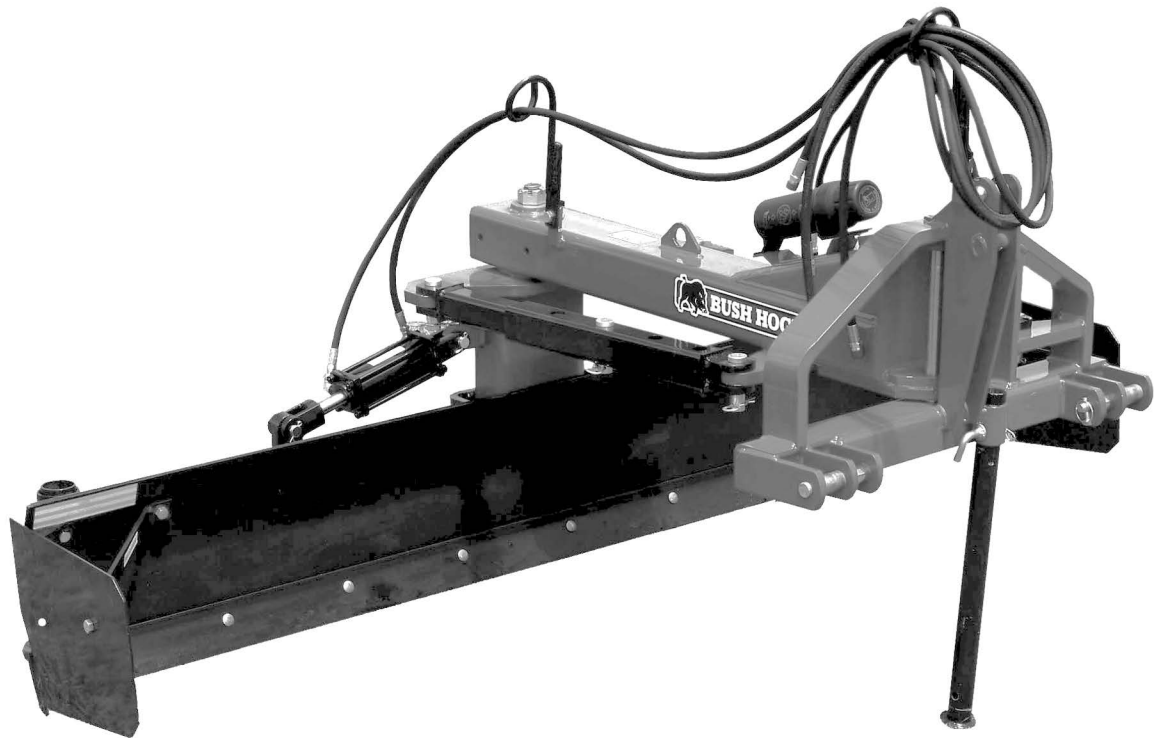

FC-BL-0002

INTRODUCTION

The 100 Series Blade is available in widths of 8' and 9' and features a heavy-duty CAT I-II three-point hitch and CAT II quick-hitch. The 9' model is rated for up to 95 PTO HP wheel-type tractors. The 100 Series blade is available with either hydraulic or manual adjustments of the mainframe swing, moldboard tilt to better fit many applications. The 3" diameter solid steel kingpin, reinforced 3/8" x 17" moldboard, and maximum of 30" of offset make the 100 blade ideal for use on larger dual wheel tractors. The 100 Series blade can be offset up to 30" left or right without relocating the cylinder. Many competitive blades can only reach their maximum offset in one direction without relocating the cylinder. Skid shoes, quick-attach end plates, CAT II quick coupler bushings, and a gauge wheel are optional equipment.

WARNING

At least 20% of the tractor's total weight must be on the front tires with the implement lifted to provide adequate traction at safe steering under good conditions. Slow down on hills, rough terrain and curves.

Front and rear, and left and right are determined by the normal direction of travel (the same as on your automobile).

INTRODUCTION

ATTENTION OWNER/OPERATOR

BEFORE OPERATING THIS MACHINE:

1. Carefully read the Operator's Manual, completely understand the Safety Messages and instructions, and know how to operate correctly both the tractor and blade.
2. Fill out the Warranty card in full. Be sure to answer all questions, including the Serial Number on the implement. Mail within 30 days of delivery date of this implement.

NOTE: Warranties are honored only if completed "Owner Registration and Warranty" forms are received by Bush Hog within thirty days of delivery of the implement.

3. Record the Model and Serial Numbers on Warranty Page on the following page of this Operator's Manual. Keep this as part of the permanent maintenance file for the Implement.

⚠ WARNING

TO AVOID DEATH OR SERIOUS INJURY:

- ONLY use genuine Bush Hog replacement parts, which have been validated and tested to use on Bush Hog equipment by the manufacturer.
- The equipment manufacturer cannot verify the material or structural integrity of third-party supplied non-genuine replacement parts.
- Using non-genuine parts can result in the part failing, creating hazardous conditions for operator and bystanders.

Contact local dealer or Bush Hog about repair parts at:
2501 Griffin Ave., Selma, AL 36701
Customer Service: 800-363-6096.
Email: contactus@bushhog.com www.algqr.com/bpm



⚠ WARNING

Cancer and Reproductive Harm
www.P65Warnings.ca.gov D859

INTRODUCTION

BUSH HOG LIMITED WARRANTY



INTRODUCTION

Bush Hog warrants to the original purchaser of any new Bush Hog equipment, purchased from an authorized Bush Hog dealer, that the equipment be free from defects in material and workmanship for a period of one (1) year for non-commercial, state and municipalities' use and ninety (90) days for commercial use from date of retail sale. The obligation of Bush Hog to the purchaser under this warranty is limited to the repair or replacement of defective parts.

Replacement or repair parts installed in the equipment covered by this limited warranty are warranted for ninety (90) days from the date of purchase of such part or to the expiration of the applicable new equipment warranty period, whichever occurs later. Warranted parts shall be provided at no cost to the user at an authorized Bush Hog dealer during regular working hours. Bush Hog reserves the right to inspect any equipment or parts which are claimed to have been defective in material or workmanship.

DISCLAIMER OF IMPLIED WARRANTIES & CONSEQUENTIAL DAMAGES

Bush Hog's obligation under this limited warranty, to the extent allowed by law, is in lieu of all warranties, implied or expressed, **INCLUDING IMPLIED WARRANTIES OF MERCHANTABILITY AND FITNESS FOR A PARTICULAR PURPOSE** and any liability for incidental and consequential damages with respect to the sale or use of the items warranted. Such incidental and consequential damages shall include but not be limited to: transportation charges other than normal freight charges; cost of installation other than cost approved by Bush Hog; duty; taxes; charges for normal service or adjustment; loss of crops or any other loss of income; rental of substitute equipment, expenses due to loss, damage, detention or delay in the delivery of equipment or parts resulting from acts beyond the control of Bush Hog.

THIS LIMITED WARRANTY SHALL NOT APPLY:

1. To vendor items which carry their own warranties, such as engines, tires, and tubes.
2. If the unit has been subjected to misapplication, abuse, misuse, negligence, fire or other accident.
3. If parts not made or supplied by Bush Hog have been used in connection with the unit, if, in the sole judgment of Bush Hog such use affects its performance, stability or reliability.
4. If the unit has been altered or repaired outside of an authorized Bush Hog dealership in a manner which, in the sole judgment of Bush Hog, affects its performance, stability or reliability.
5. To normal maintenance service and normal replacement items such as gearbox lubricant, hydraulic fluid, worn blades, or to normal deterioration of such things as belts and exterior finish due to use or exposure.
6. To expendable or wear items such as teeth, chains, sprockets, belts, springs and any other items that in the company's sole judgment is a wear item.

NO EMPLOYEE OR REPRESENTATIVE OF BUSH HOG IS AUTHORIZED TO CHANGE THIS LIMITED WARRANTY IN ANY WAY OR GRANT ANY OTHER WARRANTY UNLESS SUCH CHANGE IS MADE IN WRITING AND SIGNED BY BUSH HOG'S SERVICE MANAGER, 2501 GRIFFIN AVE., SELMA, ALABAMA 36703.



Record the model number, serial number and date purchased. This information will be helpful to your dealer if parts or service are required.

MODEL NUMBER _____

SERIAL NUMBER _____

MAKE CERTAIN THE WARRANTY HAS BEEN FILED WITH BUSH HOG
SELMA, ALABAMA

DATE OF RETAIL SALE _____



BUSH HOG®

ASSEMBLY SECTION

Assembly Section 3-1

ASSEMBLY

The basic Bush Hog 100 Series is shipped in two bundles - the Mainframe, the A-Frame, and the Moldboard Carrier as one bundle and the Moldboard as the second bundle. For full hydraulic operation, Cylinders, Hose, and Hose Retainers are shipped as separate bundles. For manual operation, Adjust Links are shipped as separate bundles for the pivot and swing positions. The tilt is adjusted with an Index Pin in the Carrier. Remove the Moldboard Pivot Pin from the Moldboard and clean all paint from the Pin. Install Moldboard on the Moldboard Carrier.



Chock in a secure position while the Hydraulic Cylinders are inoperative or install the Tilt Pin to prevent tipping.

ASSEMBLY

A Planer Wheel is provided as Accessory Equipment with this machine. It is shipped in two separate bundles. One bundle consists of the Mounting Bracket and the Planer Wheel Beam. The second bundle consists of the Caster Fork Arrangement. To assemble, drill two holes in the Mainframe as indicated by the drawing on the following page. Install the Mounting Bracket on the Mainframe of the Blade, then install the Caster Fork into the Planer Wheel Main Beam. Lubricate the two Bushings in the Planer Wheel Bracket at grease fittings provided.

Additional accessories are provided for use with the Planer Wheel: Hydraulic Cylinder or Ratchet Jack.

Your Bush Hog 100 Series is designed to be used with either a standard Category 1 or 2, 3-Point Hitch or Quick Coupler. The Category 2, 3-Point, is standard. To convert to Category 1, 3-Point, it is necessary to remove the Special Bushing in the Upper Link.

If Category 1 or 2 Quick Coupler is to be used, it will be necessary to assemble Special Bushings on the two lower Hitch Pins. See Figure **Asm-0020**

Category II

Add Bushing (Part # 0781340000) into the 2 lower Hitch positions of A-Frame so that Bushings are located on Outer Slot of divided section.

Category I

The lower 2 Hitch points utilize the Inner portion of the divided section by using Bushing (Part # 0781130000). Make certain Bushing is on the Inner portion of the divided Slot of the Lower Hitch Points

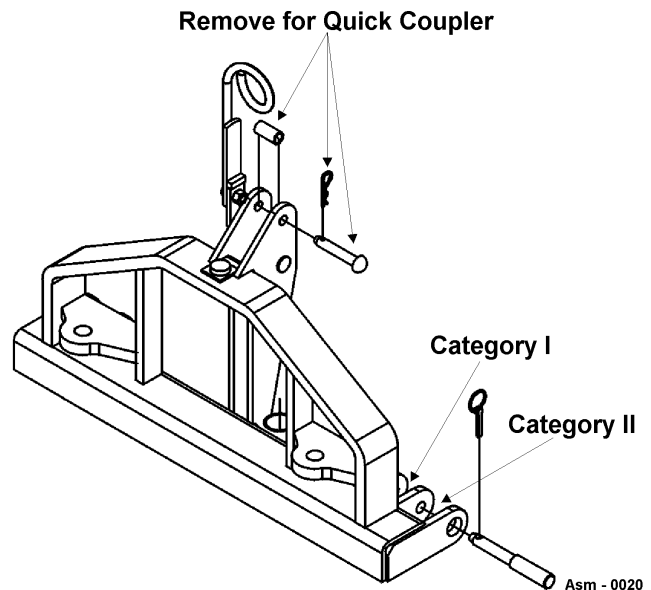

ASSEMBLY

Planer Wheel

If the Planer Wheel is to be used, it will be necessary to drill (2) holes, 0.688 diameter. See illustration below.

When mounting the Hydraulic Cylinder to the Planer Wheel Assembly, it is recommended by the manufacturer that the Rod End be attached to the Lug on the Planer Wheel Beam Weldment, as shown in the illustration below.

Operation - Special Notice

The Planer Wheel is provided to give depth control for grading. Lower the Blade to ground level and then set the Planer Wheel height.

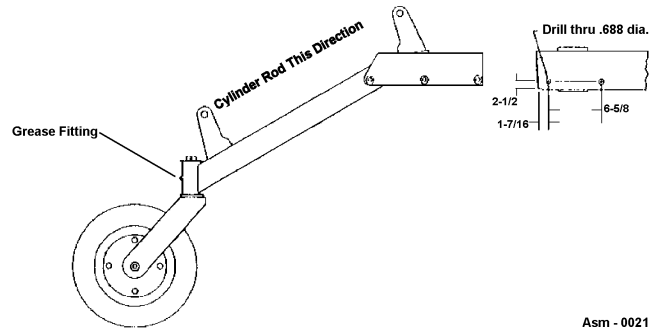

ASSEMBLY



Do not drop the complete Blade with the Planer Wheel in the down position. The impact may damage the Planer Wheel or Hydraulic Cylinder.

Attach Moldboard Tilt Cylinder with the Rod End attached to the Moldboard (Figure **Asm-0002**) or optional Manual Adjusting links.

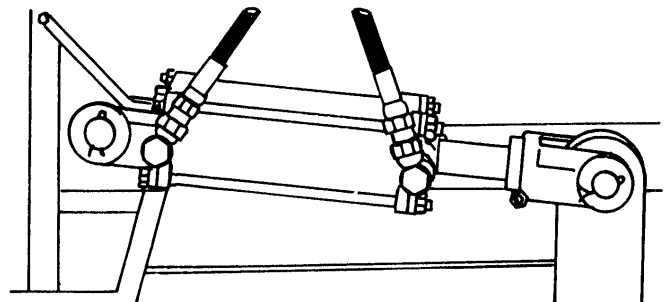

ASSEMBLY

ASSEMBLY

Attach the Moldboard Pivot Cylinder as shown in Figure **Asm-0003** or optional Manual Adjusting Links.

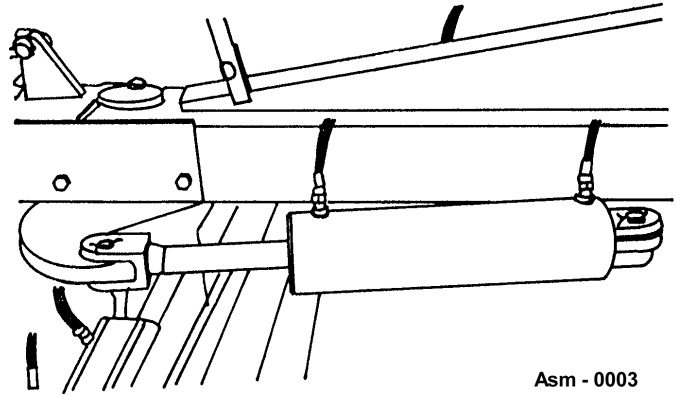

Asm - 0003

Attach the Mainframe Swing Cylinder as shown in Figure **Asm-0004** or optional Manual Adjusting Links.

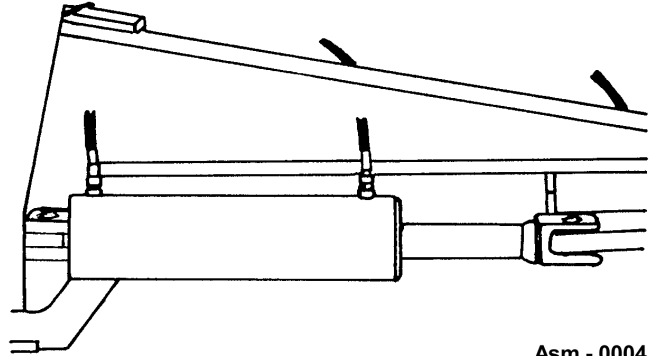

Asm - 0004

ASSEMBLY

Gauge Wheel (Extra Equipment)

Mounting Holes must be drilled, for mounting the Gauge Wheel to the Mainframe (See Planner Wheel illustration in Maintenance Section 5-2.) Dual or Single Wheels with laminated puncture proof or pneumatic tires are optional. Assembly of the Hydraulic Cylinder to the Gauge Wheel Beam must be in the direction as shown in Figure **Asm-0005**. It is also important to route the hydraulic Hose through the Hose Retainers designed for this equipment.

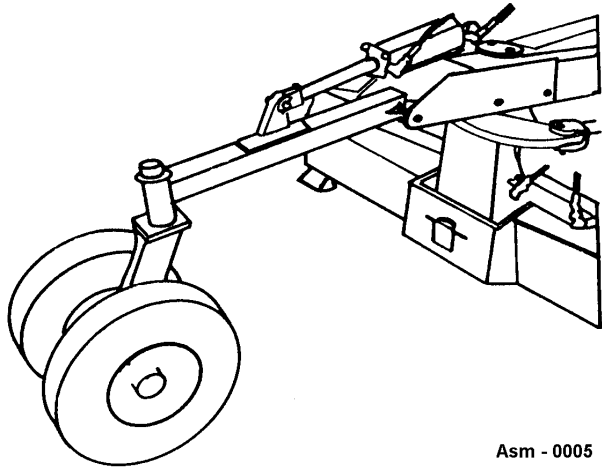

Asm - 0005

Skid Shoes & Quick Tack End Plates (Extra Equipment)

Skid Shoes prevent gouging and scalping and increase Blade life. End Plates help move larger quantities of bulk material. Install as shown in Figure **Asm-0022**

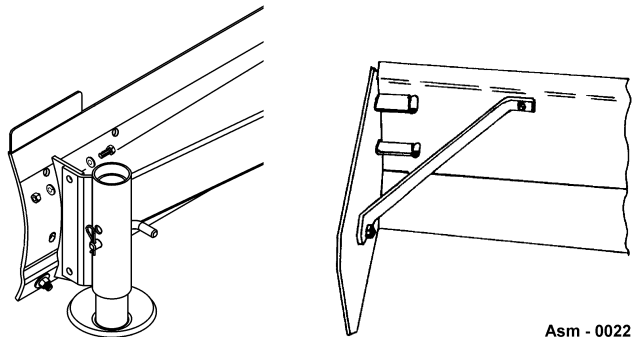

Asm - 0022

ASSEMBLY

ASSEMBLY

HYDRAULIC SYSTEM

The Hydraulic Cylinders are designed to be used in conjunction with your tractor's Hydraulic System. The Cylinders and Hose are designed for maximum system pressure of 2500 PSI.

WARNING

Keep Cylinders and Hoses free from internal contamination. Never leave a disconnected Hose end open. Use a Sealant when attaching Hydraulic Hose to Cylinder. Do not over tighten fittings as this will break out the Cylinder Port Housings. Do not operate with hydraulic oil leaking. Oil is expensive and its presence could cause slips and falls and other hazards. **DO NOT CHECK FOR LEAKS WITH YOUR HAND. USE CARDBOARD INSTEAD.** High-pressure oil can penetrate the skin and cause tissue damage or even GANGRENE. If oil does penetrate the skin, have it REMOVED IMMEDIATELY by a surgeon skilled in this procedure.

NOTE: Never rotate Blade Tilt, Carrier Pivot, or Mainframe Pivot with hydraulics while Blade is under load. This will cause excessive load on pins and shafts which will result in damage to Blade. Remove load from Blade and then rotate.

Selector Valve (Accessory Equipment)

If the Mainframe Swing, Moldboard Pivot and Tilt are fully hydraulic, as an added feature, all three Cylinders can be operated from two remote outlets. Below is a schematic diagram showing proper routing of two Cylinders through the Selector Valve. When installing this Valve, observe all safety precautions as hydraulic lines are under high pressure (2500 PSI). If additional information is required concerning your hydraulic system, contact your Bush Hog dealer. (Figure Asm-0008).

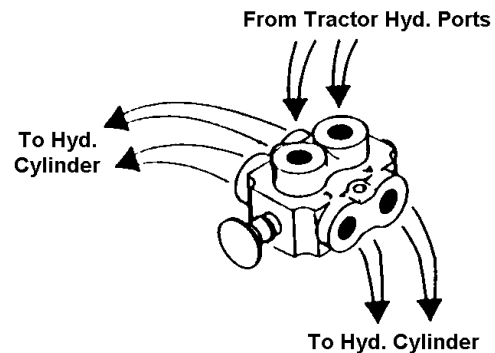

Asm - 0008

WARNING

--	--	--

TO AVOID DEATH OR SERIOUS INJURY FROM HIGH PRESSURE HYDRAULIC OIL LEAKS PENETRATING SKIN:

- DO NOT OPERATE equipment with oil or fuel leaks.
- KEEP all hydraulic hoses, lines and connections in good condition and tight before applying system pressure.
- Relieve hydraulic pressure before disconnecting lines or working on the system.
- REMOVE and replace hose if you suspect it leaks. Have dealer test it for leaks.

HIGH PRESSURE FLUID LEAKS CAN BE INVISIBLE. WHEN CHECKING FOR HYDRAULIC LEAKS AND WORKING AROUND HYDRAULIC SYSTEMS:

- DO NOT use hands to check for leaks.
- ALWAYS WEAR safety glasses with side shields (marked to comply with ANSI Z87) and impenetrable gloves.
- USE paper or cardboard to search for leaks.
- KEEP hands and body AWAY from pin holes and nozzles ejecting hydraulic fluid.
- Hydraulic fluid may cause gangrene if not surgically removed immediately by a doctor familiar with this form of injury.

D617

ASSEMBLY

HYDRAULIC CONTROL VALVE (ACCESSORY EQUIPMENT)

A 3-Spool 4-Way Hydraulic Control Valve, open center or closed center, is available as Accessory Equipment. This allows you to operate 4 Hydraulic Cylinders from two remote outlets. Connect the 3-Spool Valve to one outlet to operate three Cylinders. Use the other remote outlet to operate the fourth Cylinder. (Figure Asm-0007).

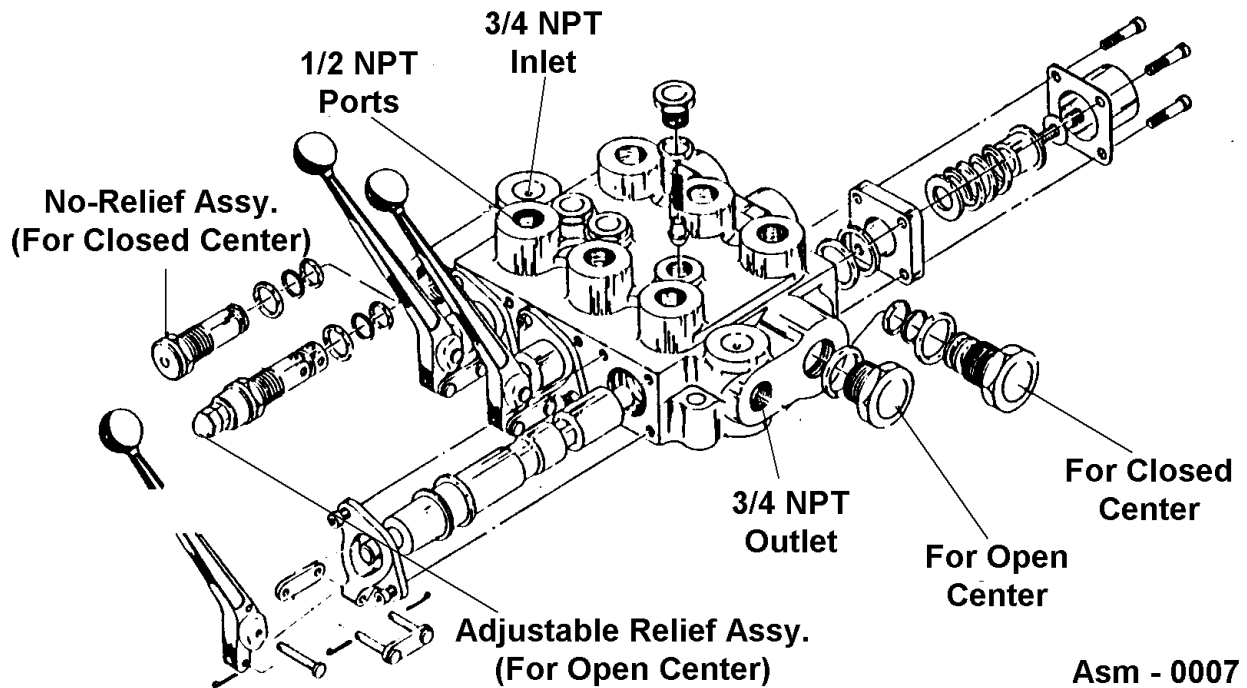

If Closed Center Valve is used, Do Not Use the Adjustable Relief Assembly. Use the No-Relief Assembly.

OPERATION SECTION

Operation Section 4-1

OPERATION

BUSH HOG 100 SERIES REAR MOUNTED BLADE OPERATING INSTRUCTIONS

Your Bush Hog 100 Series should now be assembled and inspected for any evidence of defective or damaged parts before use. Any evidence of damage should be reported to your dealer immediately.

This section of the Operator's Manual is designed to familiarize, instruct, and educate safe and proper blade use to the operator. Pictures contained in this section are intended to be used as a visual aid to assist in explaining the operation of a rear blade. Some pictures may show shields removed for purposes of clarity. NEVER OPERATE this implement without all shields in place and in good operational condition. The operator must be familiar with the blade and tractor operation and all associated safety practices before operating the blade and tractor. Proper operation of the blade, as detailed in this manual, will help ensure years of safe and satisfactory use of the rear blade.

READ AND UNDERSTAND THE ENTIRE OPERATING INSTRUCTIONS AND SAFETY SECTION OF THIS MANUAL AND THE TRACTOR MANUAL BEFORE ATTEMPTING TO USE THE TRACTOR AND IMPLEMENT. If you do not understand any of the instructions, contact your nearest authorized dealer for a full explanation. Pay close attention to all safety signs and safety messages contained in this manual and those affixed to the implement and tractor. *OPS-U- 0001str*

READ, UNDERSTAND, and FOLLOW the following Safety Messages. Death or serious injury may occur unless care is taken to follow the warnings and instructions stated in the Safety Messages. Always use good common sense to avoid hazards. (SG-2str)



PELIGRO

Si no lee ingles, pida ayuda a alguien que si lo lea para que le traduzca las medidas de seguridad. (SG-3) str

¡ LEA EL INSTRUCTIVO!



OPERATION

1. STANDARD EQUIPMENT AND SPECIFICATIONS

	100 SERIES
Maximum Horsepower 2-Wheel Drive Tractor PTO	
8'	125 HP
9'	95 HP
Maximum Horsepower Front Wheel Assist Tractor PTO	
8'	105 HP
9'	80 HP
Moldboard Width	8', 9'
Moldboard Height and Thickness	3/8" x 17"
Cutting Edge	1/2" x 6"
Support Stand	Standard
Hitch	3-Point, CAT I / CAT II, Quick Hitch
King Pin Diameter	3" Solid Steel
Adjustment Types	Manual or Hydraulic
Angle Adjustment (Left or Right)	30°
Offset (Maximum Left or Right)	7-45°
Tilt (Up and Down)	2-15°
Weight (Approximate)	
8'	836 lbs
9'	876 lbs

OPERATION

2. OPERATOR REQUIREMENTS

Safe operation of the unit is the responsibility of a qualified operator. A qualified operator has read and understands the implement and tractor Operator's Manuals and is experienced in implement and tractor operation and all associated safety practices. In addition to the safety messages contained in this manual, safety signs are affixed to the implement and tractor. If any part of the operation and safe use of this equipment is not completely understood, consult an authorized dealer for a complete explanation.

If the operator cannot read the manuals for themselves or does not completely understand the operation of the equipment, it is the responsibility of the supervisor to read and explain the manuals, safety practices, and operating instructions to the operator.

Safe operation of equipment requires that the operator wear approved Personal Protective Equipment (PPE) for the job conditions when attaching, operating, servicing, and repairing the equipment. PPE is designed to provide operator protection and includes the following safety wear:

PERSONAL PROTECTIVE EQUIPMENT (PPE)

- Always Wear Safety Glasses (with side shields marked to comply with ANSI Z87)
- Hard Hat
- Steel Toe Safety Footwear
- Gloves
- Hearing Protection
- Close Fitting Clothing
- Respirator or Filter Mask (depends on operating conditions)

OPS-U- 0002str

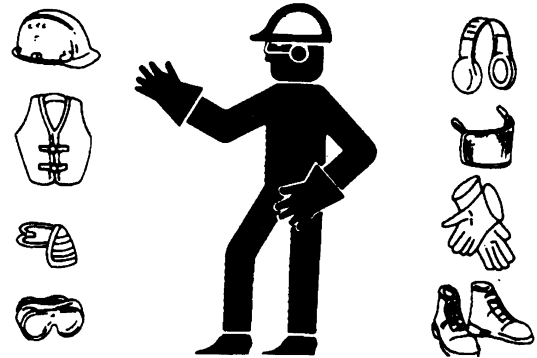

⚠ DANGER

DO NOT use drugs or alcohol immediately before or while operating the Tractor and Implement. Drugs and alcohol will affect an operator's alertness and coordination and therefore affect the operator's ability to operate the equipment safely. Before operating the Tractor or Implement, an operator on prescription or over-the-counter medication must consult a medical professional regarding any side effects of the medication that would hinder their ability to operate the Equipment safely. NEVER knowingly allow anyone to operate this equipment when their alertness or coordination is impaired. Serious injury or death to the operator or others could result if the operator is under the influence of drugs or alcohol.

(SG-27) str

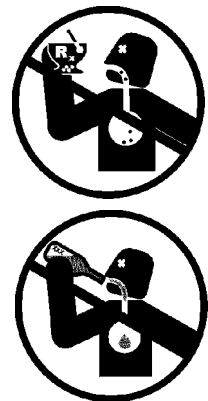

OPERATION

3. TRACTOR REQUIREMENTS

Operating the blade with a tractor that does not meet the following requirements may cause tractor or blade damage and be a potential danger to the operator and passersby.

Tractor Requirements and Capabilities

- ASABE approved Roll-Over Protective Structure (ROPS) or ROPS cab and seat belt.
- Tractor Safety Devices Slow Moving Vehicle (SMV) emblem, lighting, PTO master shield
- Tractor Horsepower Maximum
 - 2WD 8 ft - 125 HP, 9 ft - 95 HP
 - Front Wheel 8 ft - 105 HP, 9 ft - 80 HP
- Hitch - 3-Point..... CAT I, CAT II Quick Hitch
- Lifting Capacity..... 8 ft - 836 lbs., 9 ft -876 lbs.
- Front End Weight As needed to maintain 20% weight on front axle

3.1 ROPS and Seat Belt

The tractor must be equipped with a Roll-Over-Protective-Structure (ROPS), tractor cab, or roll-bar and seat belt to protect the operator from falling off the tractor, especially during a roll over where the driver could be crushed and killed. Only operate the tractor with the ROPS in the raised position and seat belt fastened. Tractor models not equipped with a ROPS and seat belt should have these life saving features installed by an authorized dealer. OPS-U- 0003str



Operate this Equipment only with a Tractor equipped with an approved roll-over-protective system (ROPS). Always wear seat belts. Death or serious injury could result from falling off the tractor, particularly during a turnover when the operator could be pinned under the ROPS. (SG-7) str



3.2 Tractor Horsepower

The power required to operate a blade is determined by the tractor PTO horsepower. For most operating conditions, the 100 rear blade requires a tractor with at least 125 HP for a 8' 2-Wheel Drive, 95 HP for a 9' 2-Wheel Drive, 105 HP for a 8' Front Wheel Assist Tractor, and 80 HP for a 9' Front Wheel Assist Tractor. Operating the blade with a tractor that does not have adequate power may damage the tractor engine. Exceeding the recommended horsepower may cause blade damage by overpowering the unit in heavy operating conditions.

OPERATION

OPERATION

3.3 Tractor 3-Point Hitch

The tractor's 3-point hitch must be rated to lift at least 1015 lbs. for the 8', and 1055 lbs. for the 9'.

The lower lift pin is machined to allow fitting either CAT I or II type hitches.

The 100 Series attaches to a tractor with a CAT I or II hitch. Refer to the tractor operator's manual for the category of the tractor used. If the hitch does not conform to the ASABE CAT I or II dimensions, the blade may not fit or raise properly. Consult an authorized dealer for possible modification procedures to mount nonconforming hitches.

Use the correct hitch pins for the hitch category being used. For a Cat I hitch, 7/8" lower hitch pins are used, and 3/4" top hitch pins are used. For a CAT II hitch, 1-1/8" lower hitch pins are used, and 1" top hitch pins are used

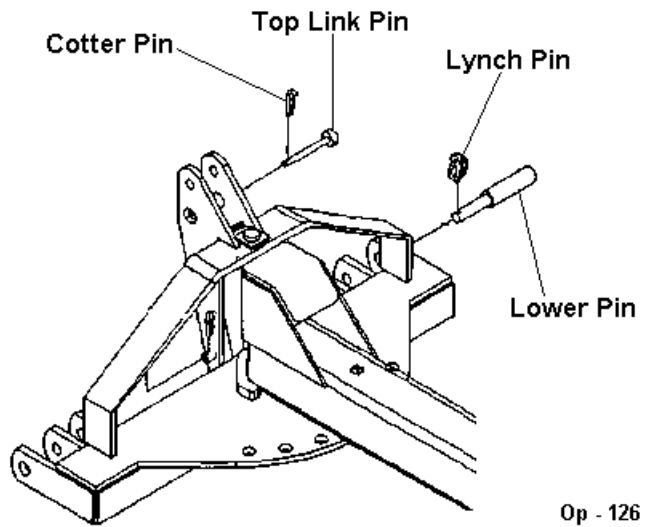

Op - 126

CAT I Implement / Hitch Specification		CAT II Implement / Hitch Specification	
Width from outside-to-outside A-frame	26-7/8"	Width from outside-to-outside A-frame	32-3/8"
Quick Hitch width inside lug to lug	27-1/8"	Quick Hitch width inside lug to lug	33-5/8"
Height from bottom hitch to top pin	18"	Height from bottom hitch to top pin	19"
Lower pin diameter	7/8"	Lower pin diameter	1-1/8"
Upper pin diameter	3/4"	Upper pin diameter	1"
Lynch pin diameter	15/32"	Lynch pin diameter	15/32"

3.4 Front End Weight

A minimum of 20% total tractor weight must be maintained on the tractor front end at all times. Front end weight is critical to maintain steering control and to prevent the tractor from rearing up while driving. If the front end is too light, add weight until a minimum of 20% total weight is reached on the front tires. Front weights and weight carriers can be purchased through an authorized tractor dealership. OPS-U-0005 str

OPERATION

4. GETTING ON AND OFF THE TRACTOR

Before getting onto the tractor, the operator must read and completely understand the implement and tractor operator manuals. If any part of either manual is not completely understood, consult an authorized dealer for a complete explanation. OPS-U- 0007str



WARNING Do not mount or dismount the Tractor while the tractor is moving. Mount the Tractor only when the Tractor and all moving parts are completely stopped. Dismounting a moving power unit can result in a crushing hazard that can cause death or serious injury. (SG-12) str



4.1 Boarding the Tractor

Use both hands and equipped handrails and steps for support when boarding the tractor. Never use control levers for support when mounting the tractor. Seat yourself in the operator's seat and secure the seat belt around you.

Never allow passengers to ride on the tractor or attached equipment. Riders can easily fall off and be seriously injured or killed from falling off and being ran over. It is the operator's responsibility to forbid all extra riders at all times. OPS-U- 0008str



DANGER Never allow children to operate, ride on, or come close to the Tractor or Implement. Usually, 16-17 year-old children who are mature and responsible can operate the implement with adult supervision, if they have read and understand the Operator's Manuals, been trained in proper operation of the tractor and Implement, and are physically large enough to reach and operate the controls easily. (SG-11) str



DANGER Never allow children or other persons to ride on the Tractor or Implement. Falling off can result in death or serious injury. (SG-10)str



4.2 Dismounting the Tractor

Before dismounting, park the tractor and implement on a reasonably level surface, apply the parking brake, idle the engine down, disengage the PTO, and lower the implement to the ground. Shut down the tractor engine according to the operator's manual, remove the key, and wait for all motion to completely stop. Never leave the seat until the tractor, its engine and all moving parts have come to a complete stop.

Use hand rails and steps when exiting the tractor. Be careful of your step and use extra caution when mud, ice, snow or other matter has accumulated on the steps or hand rails. Use all handrails and steps for support and never rush or jump off the tractor. OPS-U- 0009 str



DANGER BEFORE leaving the tractor seat lower the implement, set the parking brake and/or set the tractor transmission in parking gear, disengage the PTO, stop the engine, remove the key, and wait for all moving parts to stop. Place the tractor shift lever into a low range or parking gear to prevent the tractor from rolling. Never dismount a Tractor that is moving or while the engine is running. Operate the Tractor controls from the tractor seat only.

(SG-9)str

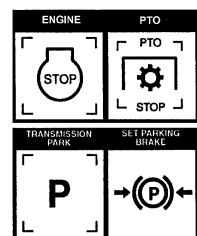

OPERATION

5. STARTING THE TRACTOR

The operator must have a complete understanding of the placement, function, and operational use of all tractor controls before starting the tractor. Review the tractor operator's manual and consult an authorized dealer for tractor operation instructions if needed.

Essential Tractor Controls:

- Locate the light control switch.
- Locate the engine shut off control.
- Locate the brake pedals and the clutch.
- Locate the PTO control.
- Locate the 3-point hitch control lever.
- Locate the hydraulic remote control levers

Before starting the tractor ensure the following:

- Conduct all pre-start operation inspection and service according to the tractor operator's manual.
- Make sure all guards, shields, and other safety devices are securely in place.
- The parking brake is on.
- The PTO control lever is disengaged.
- The 3-point hitch control lever is in the lowered position.
- The hydraulic remote control levers are in the neutral position.
- The tractor transmission levers are in park or neutral.

Refer to the tractor owner's manual for tractor starting procedures. Only start the tractor while seated and belted in the tractor operator's seat. Never bypass the ignition switch by short circuiting the starter solenoid.

After the tractor engine is running, avoid accidental contact with the tractor transmission to prevent sudden and unexpected tractor movement.



Never run the Tractor engine in a closed building or without adequate ventilation. The exhaust fumes can be hazardous to your health. (SG-23) str



Start tractor only when properly seated in the Tractor seat. Starting a tractor in gear can result in death or serious injury. Read the Tractor operators manual for proper starting instructions. (SG-13) str



OPERATION

6. CONNECTING THE REAR BLADE TO THE TRACTOR

Use extreme caution when connecting the blade to the tractor. The rear blade should be securely resting at ground level or set on blocks. Keep hands and feet from under the blade and clear of pinch points between the tractor hitch arms and blade pins. OPS-0011_A str



Always shut the Tractor completely down, place the transmission in park, and set the parking brake before you or anyone else attempts to connect or disconnect the Implement and Tractor hitches. (S3PT-15) str

6.1 Connecting the Rear Blade

1. Shorten or remove the tractor drawbar to avoid interference when raising and lowering the rear blade.
2. Board the tractor and start the engine. Position the tractor to the blade with the 3-point lift arms positioned between the respective set of blade A-frame lift lugs. **Note:** Set the 3-point lift control to "Position Control" so that the lift arms maintain a constant height when attaching the blade. See the tractor Operator's Manual for correct settings when attaching 3-point equipment.
3. Turn off the tractor engine, set the parking brake, place the tractor in park, and dismount.
4. One lift arm at a time, align arm end hole between the set of holes of A-frame lift lugs. Insert hitch pin through the lug and arm holes and insert retaining pin into hitch pin. Walk around to opposite side and repeat procedure for remaining lift arm and hitch pin.
5. Extend or retract the 3-point top link to align its end hole with the holes of the blade's top link. Insert the top link pin and retain with hairpin.
6. Adjust any lower link check chains, guide blocks, or sway blocks to prevent the blade from swaying side to side and possible contact with tractor rear tires.

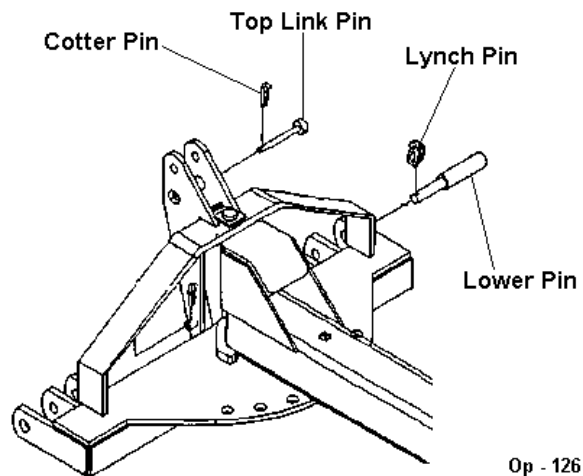

Never work under the Implement, the framework, or any lifted component unless the Implement is securely supported or blocked up to prevent sudden or inadvertent falling which could cause death or serious injury. (SG-14)str



OPERATION

7. PRE-OPERATION INSPECTION AND SERVICE

Before each use, a pre-operation inspection and service of the implement and tractor must be performed. This includes routine maintenance and scheduled lubrication, inspecting that all safety devices are equipped and functional, and performing needed repairs. DO NOT operate the unit if the pre-operation inspection reveals any condition affecting safe operation. Perform repairs and replacement of damaged and missing parts as soon as noticed. By performing a thorough pre-operation inspection and service, valuable down time and repair cost can be avoided. OPS-U-0029str



Periodically inspect all moving parts for wear and replace when necessary with authorized service parts. Look for loose fasteners, worn or broken parts, and leaky or loose fittings. Make sure all pins have cotter pins and washers. Serious injury may occur from not maintaining this machine in good working order. (SG-21)str



7.1 Tractor Pre-Operation Inspection/Service

Refer to the tractor operator's manual to ensure a complete pre-operation inspection and scheduled service is performed according to the manufacturer's recommendations. The following are some of the items that require daily service and inspection:

- Tire condition/air pressure
- Wheel lug bolts
- Steering linkage
- PTO shield
- SMV sign is clean and visible
- Tractor's lights are clean and functional
- Tractor Seat belt is in good condition
- ROPS is in the raised position
- No tractor oil leaks
- Radiator free of debris
- Engine oil level and condition
- Engine coolant level and condition
- Power brake fluid level
- Power steering fluid level
- Fuel condition and level
- Sufficient lubrication at all lube points
- Air filter condition *OPS-U-0030 str*



OPERATION

7.2 Blade Pre-Operation Inspection/Service

Before each blade use, a complete inspection and service is required to ensure the blade is in a good and safe working condition. Damaged and/or broken parts should be repaired and/or replaced immediately. To ensure the blade is ready for operation, conduct the following. OPS- 0020_A

The operator's manual and safety signs affixed on the unit contain important instructions on the safe and proper use of the equipment. Maintain these important safety features on the implement in good condition to ensure the information is available to the operator at all times.

- Ensure the manual canister is secured to the equipment with the operator's manual inside.
- Ensure all safety signs are in place and legible. Replace missing, damaged, and illegible decals. *OPS-U- 0011 str*



OPERATION

BLADE & BOX BLADE PRE-OPERATION INSPECTION



Blade ID# _____

Date : _____

Make: _____

Shift: _____



Before conducting the inspection, make sure the tractor engine is off, all rotation has stopped and the tractor is in park with the parking brake engaged. Make sure the blade is resting on the ground or securely blocked up and all hydraulic pressure has been relieved.

OPERATION

Item	Condition at Start of Shift	Specific Comments if not OK
The Operator's Manual is in the canister		
All safety decals are in place and legible		
The hitch connection pins are properly retained		
There are no cracks in the Hitch		
All frame bolts are in place and tight		
The blade swing, angle & tilt pins are properly lubricated and retained.		
The Blade edge & moldboard are clear of mud and debris.		
The blade edge attachment bolts are in place and tight.		
The blade edge is not chipped, cracked or bent.		
The Storage Stands are in place & in good condition.		
The skid shoes are in good condition.		
The hydraulic cylinder pins are in place and retained.		
There are no leaking or damaged hoses.		
There is no evidence of hydraulic leaks.		
The gauge wheel(s) are in good condition & lubricated.		
The scarifier shanks are properly retained.		
The scarifier points are in good condition.		

Operator's Signature: _____

DO NOT OPERATE an UNSAFE TRACTOR or IMPLEMENT

OPERATION

TRACTOR PRE-OPERATION INSPECTION



Tractor ID# _____ Make: _____

Date: _____ Shaft: _____



WARNING

Before conducting the inspection, make sure the tractor engine is off, all rotation has stopped and the tractor is in park with the parking brake engaged. Make sure the implement is resting on the ground or securely blocked up and all hydraulic pressure has been relieved.

Item	Condition at Start of Shift	Specific Comments if not OK
The flashing lights function properly		
The SMV Sign is clean and visible		
The tires are in good condition with proper pressure		
The wheel lug bolts are tight		
The tractor brakes are in good condition		
The steering linkage is in good condition		
There are no visible oil leaks		
The hydraulic controls function properly		
The ROPS or ROPS Cab is in good condition		
The seatbelt is in place and in good condition		
The 3-point hitch is in good condition		
The drawbar pins are securely in place		
The PTO master shield is in place		
The engine oil level is full		
The brake fluid level is full		
The power steering fluid level is full		
The fuel level is adequate		
The engine coolant fluid level is full		
The radiator is free of debris		
The air filter is in good condition		

Operator's Signature: _____

DO NOT OPERATE an UNSAFE TRACTOR or IMPLEMENT

OPERATION

OPERATION

8. DRIVING THE TRACTOR AND IMPLEMENT

Safe tractor transport requires the operator possess a thorough knowledge of the model being operated and precautions to take while driving with an attached implement. Ensure the tractor has the capacity to handle the weight of the implement and the tractor operating controls are set for safe transport. To ensure safety while driving the tractor with an attached implement, review the following. OPS-U- 0012str

DANGER

This Implement may be wider than the Tractor. Be careful when operating or transporting this equipment to prevent the Implement from running into or striking sign posts, guard rails, concrete abutments or other solid objects. Such an impact could cause the Implement and Tractor to pivot violently resulting in loss of steering control, death, or serious injury. Never allow the Implement to contact obstacles. (S3PT-12)str

WARNING

Transport only at speeds where you can maintain control of the equipment. Serious accidents and injuries can result from operating this equipment at high speeds. Understand the Tractor and Implement and how it handles before transporting on streets and highways. Make sure the Tractor steering and brakes are in good condition and operate properly.



Before transporting the Tractor and Implement, determine the proper transport speeds for you and the equipment. Make sure you abide by the following rules:

Test the tractor at a slow speed and increase the speed slowly. Apply the Brakes smoothly to determine the stopping characteristics of the Tractor and Implement. As you increase the speed of the Tractor the stopping distance increases. Determine the maximum transport speed not to exceed 20 mph (30 kph) for transporting this equipment.

Test the equipment at a slow speed in turns. Increase the speed through the turn only after you determine that the equipment can be operated at a higher speed. Use extreme care and reduce your speed when turning sharply to prevent the tractor and implement from turning over. Determine the maximum turning speed for you and this equipment before operating on roads or uneven ground.



Only transport the Tractor and Implement at the speeds which allow you to properly control the equipment.

Be aware of the operating conditions. Do not operate the Tractor with weak or faulty brakes or worn tires. When operating down a hill or on wet or rain slick roads, the braking distance increases: use extreme care and reduce your speed. When operating in traffic always use the Tractor's flashing warning lights and reduce your speed. Be aware of traffic around you and watch out for the other guy. (SG-19)str

OPERATION

8.1 Starting the Tractor

The procedure to start the tractor is model specific. Refer to the tractor operator's manual for starting procedures for your particular tractor. Consult an authorized dealer if the starting procedure is unclear. Ensure the 3-point control lever is in the lowered position and the PTO is disengaged before starting the tractor. OPS-U-0033str



8.2 Brake and Differential Lock Setting

Make sure the tractor brakes are in good operating condition. Tractor brakes can be set to operate independently allowing single rear wheel braking action or locked together to provide simultaneous rear wheel braking. FOR MOST DRIVING AND OPERATING CONDITIONS, THE BRAKE PEDALS SHOULD BE LOCKED TOGETHER TO PROVIDE THE MOST EFFECTIVE BRAKING ACTION.

Always disengage the tractor differential lock when turning. When engaged the differential lock will prevent or limit the tractor from turning. During normal cutting conditions, locking the differential provides no benefit and should not be used.

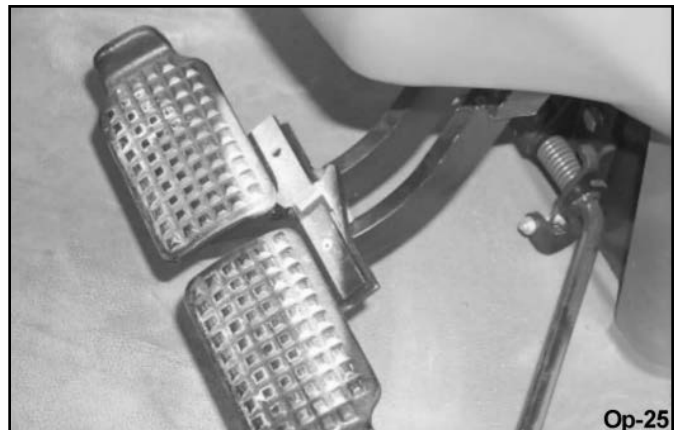

⚠️ WARNING

Be aware of the operating conditions. Do not operate the Tractor with weak or faulty brakes. When operating down a hill or on wet or rain slick roads, the braking distance increases. Use extreme care and reduce your speed in these conditions. When operating in traffic, always use the Tractor's flashing warning lights and reduce your speed. Be aware of traffic around you and watch out for the other guy. OPS-U- 0013 str

OPERATION

8.3 Driving the Tractor and Blade

Start off driving at a slow speed and gradually increase your speed while maintaining complete control of the tractor and blade. Moving slowly at first will also prevent the tractor from rearing up and loss of steering control. The tractor should never be operated at speeds that cannot be safely handled or which will prevent the operator from stopping quickly during an emergency. If the power steering or engine ceases operating, stop the tractor immediately as the tractor will be difficult to control.

Perform turns with the tractor and blade at slow speeds to determine how the tractor with an attached implement handles a turn. Determine the safe speed to maintain proper control of the tractor when making turns. When turning with an implement, the overall working length of the unit is increased. Allow additional clearance for the blade when turning.

To avoid overturns, drive the tractor with care and at safe speeds, especially when operating over rough ground, crossing ditches or slopes, and turning corners. Tractor wheel tread spacing should be increased when working on inclines or rough ground to reduce the possibility of tipping.

Use extreme caution when operating on steep slopes. Keep the tractor in a low gear when going downhill. DO NOT coast or free-wheel downhill. OPS- 0037_Astr

9. OPERATING THE TRACTOR AND IMPLEMENT

THE OPERATOR MUST COMPLETELY UNDERSTAND HOW TO OPERATE THE TRACTOR AND IMPLEMENT AND ALL CONTROLS BEFORE ATTEMPTING TO OPERATE.

The operator must read and understand the Safety and Operation Sections of the implement and tractor operator's manuals. These manuals must be read and explained to any operator who cannot read. Never allow someone to operate the implement and tractor without complete operating instructions.

Before starting any operation, the operator must become familiar with the area to be worked in and any obstacles and hazards contained within to ensure safety to the operator, bystanders, and equipment. Special attention should be paid to foreign debris, rough terrain, steep slopes, and passersby and animals in the area. OPS-U- 0015 str

9.1 Operating the Blade

Mainframe Swing

A double acting Hydraulic Cylinder will swing the Mainframe a maximum of 45 degrees right or left. An 8 position mechanical Adjust Link is available as Accessory Equipment.

Moldboard Pivot

A double acting Hydraulic Cylinder will pivot the Moldboard a maximum of 45 degrees right or left from perpendicular to the Mainframe. An 8 position Adjust Link is available as Accessory Equipment.

Moldboard Tilt

A double acting Hydraulic Cylinder will tilt the Moldboard a maximum of 15 degrees either side. A 5 position Adjust Link is available as Accessory Equipment.

Utility

To clean close to a fence or barn offset the Mainframe to the right or left to extend the Blade beyond the tractor tire. Be careful not to hang the Blade Tip as this could result in damage to the Blade or Mainframe. For smoothing out loose soil a fine finish can be obtained by pushing the soil with the back of the Moldboard.

Grading

Grading can be accomplished with the use of the Planer Wheel (Accessory Equipment). Set the Moldboard Pivot to the desired angle, lower the Blade to the ground and then set the depth of cut with the Hydraulic Cylinder, or Ratchet Jack. Do not drop the Planer Wheel on the ground. This could result in damage to the Planer Wheel or Hydraulic Cylinder.

OPERATION

Backfilling

The Moldboard can be manually rotated 180 degrees for backfilling operations. This position requires a careful setting of the Top Link allowing a Blade angle which does not tend to bury itself, but move more across the top of the ground. Backfilling is a very critical operation because the Blade tends to dig into the ground. The Backfilling operation should be performed with the Mainframe straight behind the tractor with the Blade set in the center position (perpendicular to the Mainframe). The work should be kept in the center of the Blade. Avoid concentrated loads on the end of the Blade. Do not ram into a load at any time as this multiplies the forces several times normal and could result in damage to your Blade. Perform all backfilling operations at slow speeds to prevent damage if the Blade hits an object. Moving snow with the Blade in the backfill position is a very delicate operation and should be performed with care. It is very easy to hit hidden objects when moving the light snow. It is also very easy to operate the Blade at too high a speed, resulting in damage.

NOTE: The warranty shall not apply to damage caused by misuse, abuse, or contact with obstructions.

9.2 Shutting Down the Implement

Park the tractor on a level surface, place the transmission in park or neutral and apply the parking brake, lower the attached implement to the ground, shut down the engine, remove the key, and wait for all motion to come to a complete stop before exiting the tractor. OPS-BL- 0002str



10. DISCONNECTING THE BLADE FROM THE TRACTOR

Before disconnecting the blade, all movement must cease. Move the blade to a level storage location and lower the unit to the ground. If the blade is not resting securely on the ground, block the blade up securely before attempting to disconnect it from the tractor.

Use extreme care to keep feet and hands from under the blade and clear of any pinch points. OPS- 0051_Astr



Always shut the Tractor completely down, place the transmission in park, and set the parking brake before you or anyone else attempts to connect or disconnect the Implement and Tractor hitches. (S3PT-15) str

OPERATION

OPERATION

When disconnecting the blade the tractor should be completely shut down and secured in position, by lowering the parking jack. Relieve hydraulic pressure by moving the control levers back and forth several times. Then extend the tractor 3-point hitch top link to remove tension on the top link hitch pin. When the pin is loose and easy to rotate, remove the pin from the blade. Next remove both lower hitch pins. OPS- 0052_C str



11. BLADE STORAGE

Properly preparing and storing the blade at the end of the season is critical to maintaining its appearance and to help ensure years of dependable service. The following are suggested storage procedures:

- Thoroughly clean all debris off the blade to prevent damage from rotting grass and standing water.
- Lubricate all blade grease points and fill gear-box oil levels as detailed in the maintenance section.
- Tighten all bolts and pins to the recommended torque.
- Check the blade for worn and damaged parts. Perform repairs and make replacements immediately so that the blade will be ready for use at the start of the next season.
- Store the blade in a clean, dry place with the mower housing resting securely on blocks or at ground level.
- Use spray touch-up enamel where necessary to prevent rust and maintain the appearance of the blade. OPS-0053_D str



Never allow children to play on or around Tractor or Implement. Children can slip or fall off the Equipment and be killed or injured. Inadvertent contact with controls can cause the Implement to shift or fall crushing themselves or others. (SG-25) str

OPERATION

12. TRANSPORTING THE TRACTOR AND IMPLEMENT

Inherent hazards of operating the tractor and implement and the possibility of accidents are not left behind when you finish working in an area. Therefore, the operator must employ good judgment and safe operation practices when transporting the tractor and implement between locations. By using good judgment and following safe transport procedures, the possibility of accidents while moving between locations can be substantially minimized. *OPS-U- 0017str*



Never allow children or other persons to ride on the Tractor or Implement. Falling off can result in death or serious injury. *(SG-10)str*



When transporting, only raise the blade enough to clear ground obstacles to prevent tipping, especially when traveling through rough terrain.

Before transporting the tractor on a public roadway or boarding a trailer for transport, the tractor brake pedals should be locked together. Locking the pedals ensures that both wheels brake simultaneously while stopping, especially when making an emergency stop.



Use extreme caution and avoid hard applications of the tractor brakes when towing heavy loads at road speeds. Never tow the implement at speeds greater than 20 MPH (32 kph). *OPS-U- 0018 str*

13. TRANSPORTING ON PUBLIC ROADWAYS

Extreme caution should be used when transporting the tractor and implement on public roadways. The tractor must be equipped with all required safety warning features including a SMV emblem and flashing warning lights to alert drivers of the tractor's presence. Remember that roadways are primarily designed for automotive drivers and most drivers will not be looking out for you, therefore, you must look out for them. Check your side view mirrors frequently and remember that vehicles will approach quickly because of the tractor's slower speed. Be extremely cautious when the piece of equipment that you are towing is wider than the tractor tire width and/or extends beyond your lane of the road. *OPS-BL-0003str*



Only tow the Implement behind a properly sized and equipped Tractor which exceeds the weight of the Implement by at least 20%. DO NOT tow the Implement behind a truck or other type of vehicle. Never tow the Implement and another Implement connected in tandem. Never tow the Implement at speeds over 20 MPH. *(STI-06)str*



OPERATION

DANGER

Never allow children or other persons to ride on the Tractor or Implement. Falling off can result in death or serious injury. (SG-10)str



WARNING

Make certain that the “Slow Moving Vehicle” (SMV) sign is installed in such a way as to be clearly visible and legible. When transporting the Equipment use the Tractor flashing warning lights and follow all local traffic regulations. (SG-6)str

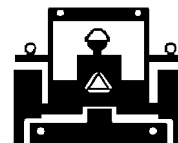

OPERATION

The SMV (Slow-Moving Vehicle) emblem is universal symbol used to alert drivers of the presence of equipment traveling on roadways at a slow speed. SMV signs are a triangular bright orange with reflective red trim for both easy day and night visibility. Make sure the SMV sign is clean and visible from the rear of the unit before transporting the tractor and implement on a public roadway. Replace the SMV emblem if faded, damaged, or no longer reflective. OPS-U- 0020str



Make sure that all tractor flashing warning lights, headlights, and brake/tail lights are functioning properly before proceeding onto public roads. While newer model tractors have plenty of lighting to provide warning signals and operating lighting, most older models are only equipped with operating lights. Consult an authorized tractor dealer for lighting kits and modifications available to upgrade the lighting on older tractor models. OPS-U- 0021str



OPERATION

When operating on public roads, have consideration for other road users. Pull to the side of the road occasionally to allow all following traffic to pass. Do not exceed the legal speed limit set in your country for agricultural tractors. Always stay alert when transporting the tractor and implement on public roads. Use caution and reduce speed if other vehicles or pedestrians are in the area. *OPS-B-0022str*



Reduce speed before turning or applying the brakes. Ensure that both brake pedals are locked together when operating on public roads. *OPS-U-0023 str*



13.1 Hauling the Tractor and Implement

Before transporting a loaded tractor and implement, measure the height and width dimensions and gross weight of the complete loaded unit. Ensure that the load will be in compliance with the legal limits set for the areas that will be traveled through. *OPS-U-0024 str*



OPERATION

OPERATION

Use adequately sized and rated trailers and equipment to transport the tractor and implement. Consult an authorized dealer to determine the proper equipment required. Using adequately sized chains, heavy duty straps, cables and/or binders, securely tie down both the front and rear of the tractor utilizing the proper tie down locations as specified by the tractor manufacturer.
OPS-U- 0025 str



Arrange the chains so that when tightened, the chains are pulling downward and against themselves. Carefully tighten the securing chains or other fasteners using boomers or binders to apply maximum tension. Use extreme care when attaching and removing the securing devices as the extreme tension involved when released has the potential to inflict serious injury.



While hauling the tractor and implement, make occasional stops to check that the tractor and implement have not moved or shifted and that the securing chains have maintained tension. If during transport a hard braking, sharp turning, or swerving action was performed, stop at the next safe location to inspect the security of the load.
OPS-U- 0026str

OPERATION

14. TROUBLESHOOTING GUIDE

Problem	Possible Cause	Remedy
Shearing M/B Carrier Pivot Pin Bolt	Lack of lubrication.	Lubricate Pivot Pin.
	Bolt not tightened properly.	Tighten bolt to proper torque.
Bent Moldboard	Small curve is normal from weld pull.	Can be removed but will not affect operation.
	Hitting hidden objects.	Know soil conditions, keep speed to a minimum.
Blade Will Not Penetrate Soil	Cutting edge is dull.	Replace cutting edge.
	Blade set to straight.	Increase Top Link length.
	Soil too hard.	Use scarifier to loosen soil.
A-Frame Bent	Hitting hidden objects in the backfill position.	Use slow speed when in unknown soil conditions.
Moldboard Digging In Too Much	Blade pitch excessive.	Adjust Top Link.
	Soft Ground	Install skid shoes, install planer wheel.
Unable to Hold Level Ground	Tractor Draft Control is lifting blade.	Set Tractor Draft Control.
	Tractor and Blade following Contour	Install planer wheel.
Hydraulic Cylinder Will Not Operate	Not enough pressure.	Check pressure.
	Valve not connected properly.	Re-plumb valve.
	Quick Coupler not completely connected.	Complete connection.
Hydraulic Pump Not Shutting Off on Closed Center System	Using open center valve.	Replace valve or conversion plug and main relief.
	Open center conversion plug.	Replace with closed center conversion plug.
	Pumping over relief valve.	Replace with no relief plug.
Oil Leaking at Hose Connection	Connection not tight.	Tighten connection.
	Did not use sealant.	Apply sealant to connection.
	Connection cracked from over-tightening.	Replace cracked connection.
	Mismatched connection threads or types.	Use correct connectors.

MAINTENANCE SECTION

Maintenance Section 5-1

MAINTENANCE

MAINTENANCE

The Bush Hog 100 Series is a rugged, heavy-duty Blade that will perform satisfactorily with the following preventive maintenance:

Lubricate the Moldboard Pivot Pin and the Moldboard Tilt Pin after every 10 hours of operation. Decals are placed in locations of grease fittings. See illustration.

If the Planer Wheel Assembly is used (Accessory Equipment), Wheel Bearings are packed at the factory with a heavy bodied grease. A Grease Fitting is provided. It is recommended that the Bearings be greased after every 10 hours of use. Also, there is a Grease Fitting provided at the pivot location of the Caster Fork. Grease after every 10 hours of use.

If the Ratchet Jack is used in place of the Hydraulic Cylinder on the Planer Wheel, grease the threads of the Jack occasionally.

Replace excessively worn Grader Blade when Ditching. A badly worn cutting edge increases the strain on the Blade and the tractor.

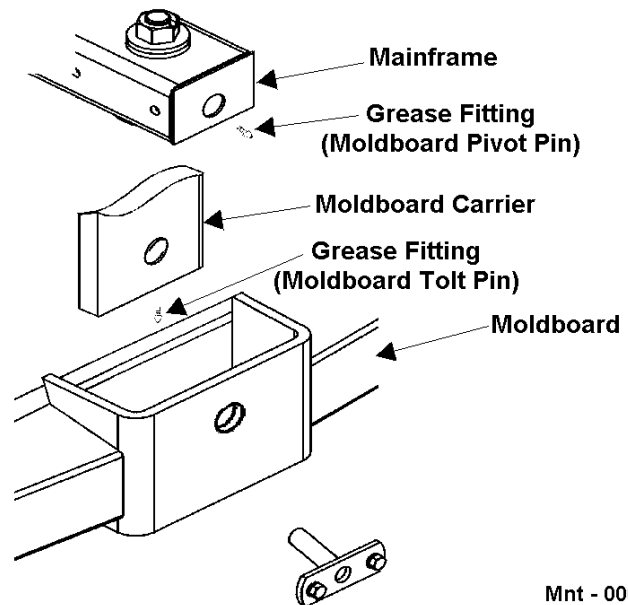

Mnt - 0003

PROPER TORQUE FOR FASTENERS

The chart lists the correct tightening torque for fasteners. When bolts are to be tightened or replaced, refer to this chart to determine the grade of bolts and the proper torque except when specific torque values are assigned in manual text.

Recommended Torque in Foot Pounds Unless Otherwise Stated in the Manual*

NOTE: These values apply to fasteners as received from supplier, dry or when lubricated with normal engine oil. They do not apply if special graphited or molydisulphide greases or other extreme pressure lubricants are used. This applies to both UNF fine and UNC coarse threads.

MAINTENANCE

MAINTENANCE

TORQUE SPECIFICATIONS - DRY TORQUE

AMERICAN Bolt Head Markings

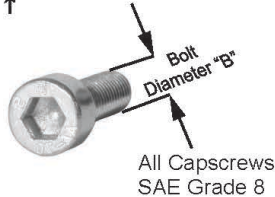
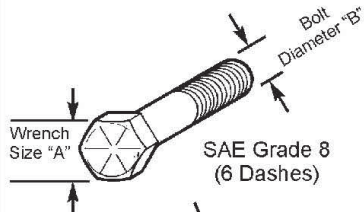

Proper torque for American fasteners.
Recommended Torque in Foot Pounds (Newton Meters).*

WRENCH SIZE (IN.) "A"	BOLT DIAMETER (IN.) "B" AND THREAD SIZE	SAE GRADE 2	SAE GRADE 5	SAE GRADE 8
7/16	1/4 - 20 UNC	6 (7)	8 (11)	12 (16)
7/16	1/4 - 28 UNF	6 (8)	10 (13)	14 (18)
1/2	5/16 - 18 UNC	11 (15)	17 (23)	25 (33)
1/2	5/16 - 24 UNF	13 (17)	19 (26)	27 (37)
9/16	3/8 - 16 UNC	20 (27)	31 (42)	44 (60)
9/16	3/8 - 24 UNF	23 (31)	35 (47)	49 (66)
5/8	7/16 - 14 UNC	32 (43)	49 (66)	70 (95)
5/8	7/16 - 20 UNF	36 (49)	55 (75)	78 (106)
3/4	1/2 - 13 UNC	49 (66)	76 (103)	106 (144)
3/4	1/2 - 20 UNF	55 (75)	85 (115)	120 (163)
7/8	9/16 - 12 UNC	70 (95)	109 (148)	153 (207)
7/8	9/16 - 18 UNF	79 (107)	122 (165)	172 (233)
15/16	5/8 - 11 UNC	97 (131)	150 (203)	212 (287)
15/16	5/8 - 18 UNF	110 (149)	170 (230)	240 (325)
1-1/8	3/4 - 10 UNC	144 (195)	266 (360)	376 (509)
1-1/8	3/4 - 16 UNF	192 (260)	297 (402)	420 (569)
1-5/16	7/8 - 9 UNC	166 (225)	430 (583)	606 (821)
1-5/16	7/8 - 14 UNF	184 (249)	474 (642)	668 (905)
1-1/2	1 - 8 UNC	250 (339)	644 (873)	909 (1232)
1-1/2	1 - 12 UNF	274 (371)	705 (955)	995 (1348)
1-1/2	1 - 14 UNF	280 (379)	721 (977)	1019 (1381)
1-11/16	1-1/8 - 7 UNC	354 (480)	795 (1077)	1288(1745)
1-11/16	1-1/8 - 12 UNF	397 (538)	890 (1206)	1444 (1957)
1-7/8	1-1/4 - 7 UNC	500 (678)	1120 (1518)	1817 (2462)
1-7/8	1-1/4 - 12 UNF	553 (749)	1241 (1682)	2013 (2728)
2-1/16	1-3/8 - 6 UNC	655 (887)	1470 (1992)	2382 (3228)
2-1/16	1-3/8 - 12 UNF	746 (1011)	1672 (2266)	2712 (3675)
2-1/4	1-1/2 - 6 UNC	870 (1179)	1950 (2642)	3161 (4283)
2-1/4	1-1/2 - 12 UNF	979 (1327)	2194 (2973)	3557 (4820)

METRIC

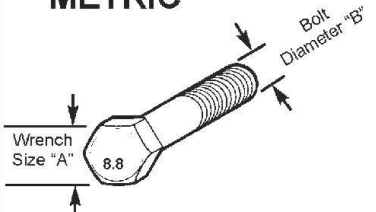

Numbers appearing on bolt heads indicate ASTM class.

*Use 75% of the specified torque value for plated fasteners. Use 85% of the specified torque values for lubricated fasteners.

Proper torque for Metric fasteners.
Recommended torque in Foot Pounds (Newton Meters).*

WRENCH SIZE (mm) "A"	BOLT DIA. (mm) "B"	ASTM 4.6	ASTM 8.8	ASTM 9.8	ASTM 10.9
8	5	1.8 (2.4)		5.1 (6.9)	6.5 (8.8)
10	6	3 (4)		8.7 (12)	11.1 (15)
13	8	7.3 (10)		21.1 (29)	27 (37)
16	10	14.5 (20)		42 (57)	53 (72)
18	12	25 (34)	74 (100)	73 (99)	93 (126)
21	14	40 (54)	118 (160)	116 (157)	148 (201)
24	16	62 (84)	167 (226)	181 (245)	230 (312)
30	20	122 (165)	325 (440)		449 (608)
33	22		443 (600)		611 (828)
36	24	211 (286)	563 (763)		778 (1054)
41	27		821 (1112)		1138 (1542)
46	30	418 (566)	1119 (1516)		1547 (2096)

Mnt-B-0005



TO THE OWNER/OPERATOR/DEALER

To keep your implement running efficiently and safely, read your manual thoroughly and follow these directions and the Safety Messages in this Manual. The Table of Contents clearly identifies each section where you can easily find the information you need.

The OCCUPATIONAL SAFETY AND HEALTH ACT (1928.51 Subpart C) makes these minimum safety requirements of tractor operators:

REQUIRED OF THE OWNER:

1. Provide a Roll-Over-Protective Structure that meets the requirements of this Standard; and
2. Provide Seat belts that meet the requirements of this paragraph of this Standard and SAE J4C; and
3. Ensure that each employee uses such Seat belt while the tractor is moving; and
4. Ensure that each employee tightens the Seat belt sufficiently to confine the employee to the protected area provided by the ROPS.

REQUIRED OF THE OPERATOR:

1. Securely fasten seat belt if the tractor has a ROPS.
2. Where possible, avoid operating the tractor near ditches, embankments, and holes.
3. Reduce speed when turning, crossing slopes, and on rough, slick, or muddy surfaces.
4. Stay off slopes too steep for safe operation.
5. Watch where you are going - especially at row ends, on roads, and around trees.
6. Do not permit others to ride.
7. Operate the tractor smoothly - no jerky turns, starts, or stops.
8. Hitch only to the drawbar and hitch points recommended by the tractor manufacturer.
9. When the tractor is stopped, set brakes securely and use park lock, if available.

X Keep children away from danger all day, every day...

X Equip tractors with rollover protection (ROPS) and keep all machinery guards in place...

X Please work, drive, play and live each day with care and concern for your safety and that of your family and fellow citizens.



BUSH HOG[®]

**100 Series
Rear Mounted Blade**

100 Series-SOM 08/22
Printed U.S.A

P/N 00786975C