



This Manual applies to Models with Serial Numbers 271855 and above.

# HT417 HT417H

# BUSH HOG®

## HAY TEDDER

Published 08/22

Part No. 50068961

## OPERATOR'S MANUAL



This Operator's Manual is an integral part of the safe operation of this machine and must be maintained with the unit at all times. **READ, UNDERSTAND, and FOLLOW** the Safety and Operation Instructions contained in this manual before operating the equipment. *C01-Cover str*

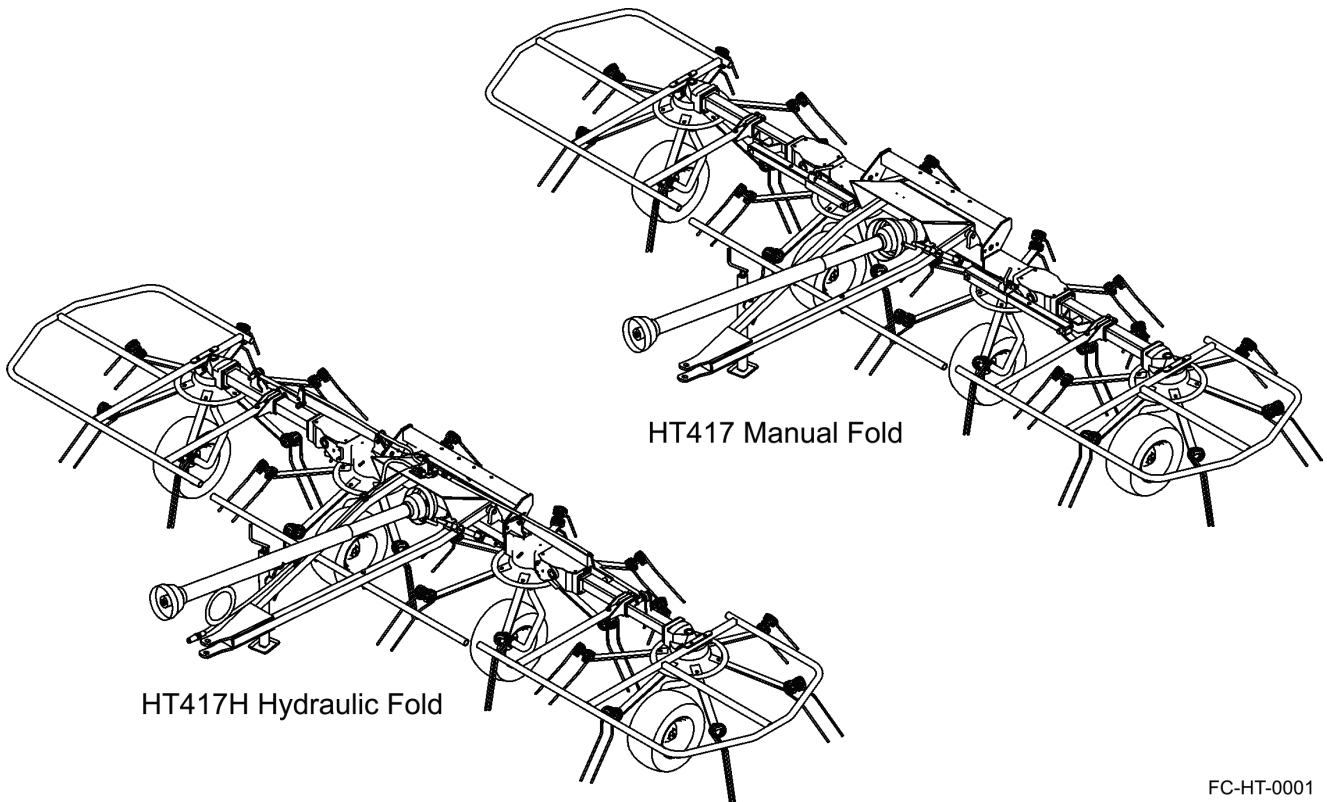

FC-HT-0001

### BUSH HOG®

2501 Griffin Ave.  
Selma, AL 36703  
334-874-2700  
www.bushhog.com

Bush Hog Web Page



www.algqr.com/bwe

**¡ATENCIÓN!**  
LEA EL INSTRUCTIVO



Si No Lee Ingles, Pida Ayuda a Alguien Que Se Lo Lea Para Que le Traduzca Las Medidas de Seguridad

**A™ MEMBER OF THE ALAMO GROUP**  
ALWAYS ON THE CUTTING EDGE®

## To the Owner/Operator/Dealer

All implements with moving parts are potentially hazardous. There is no substitute for a cautious, safe-minded operator who recognizes the potential hazards and follows reasonable safety practices. The manufacturer has designed this implement to be used with all its safety equipment properly attached to minimize the chance of accidents.

**BEFORE YOU START!** Read the safety messages on the implement and shown in your manual. Observe the rules of safety and common sense!

# **WARNING**

### TO AVOID SERIOUS INJURY OR DEATH:

1. READ AND UNDERSTAND OPERATOR'S MANUAL.
2. TRACTOR MUST BE EQUIPPED WITH ROLL-OVER PROTECTION (ROPS) AND SWAY CHAINS.
3. ALWAYS WEAR SAFETY GLASSES, SAFETY SHOES AND SEAT BELT FASTENED TIGHTLY.
4. STOP TRACTOR, LOCK BRAKES, AND BLOCK UP OR SUPPORT IMPLEMENT SECURELY BEFORE WORKING UNDER RAISED COMPONENTS.
5. ALLOW NO RIDERS AT ANY TIME ON TRACTOR OR IMPLEMENT. FALLING OFF CAN KILL.
6. KEEP BYSTANDERS CLEAR OF MOVING PARTS AND WORKING AREA. KEEP CHILDREN AWAY!
7. DO NOT LIFT, LOWER, OR OPERATE UNLESS EVERYONE IS CLEAR OF IMPLEMENT.
8. USE INCREASED CAUTION ON SLOPES & NEAR BANKS AND DITCHES TO PREVENT OVERTURN.
9. LOCK LIFT LEVER UP FOR TRANSPORT. HAVE SMV SIGN VISIBLE. FOLLOW LOCAL LAWS.
10. USE PARKING STAND OR BLOCK UP WHEN UNHITCHING FROM TRACTOR.

999200

### WARRANTY INFORMATION:

Read and understand the complete Warranty Statement found in this Manual. Fill out the Warranty Registration Form in full and return it to within 30 Days. Make certain the Serial Number of the Machine is recorded on the Warranty Card and on the Warranty Form that you retain.

# Table of Contents

<b>SAFETY SECTION .....</b>	<b>1 - 1</b>
SAFETY MESSAGES .....	1 - 2
EQUIPMENT OPERATION SAFETY INSTRUCTIONS AND PRACTICES .....	1 - 5
CONNECTING OR DISCONNECTING IMPLEMENT SAFETY INSTRUCTIONS AND PRACTICES .....	1 - 8
TRANSPORTING SAFETY INSTRUCTIONS AND PRACTICES .....	1 - 9
PARTS INFORMATION .....	1 - 12
Storage and Parking Safety Instructions and Practices .....	1 - 12
Concluding Safety Instructions and Practices .....	1 - 12
DECAL LOCATION.....	1 - 12
DECAL DESCRIPTION .....	1 - 15
FEDERAL LAWS AND REGULATIONS .....	1 - 18
<b>INTRODUCTION SECTION .....</b>	<b>2 - 1</b>
ATTENTION OWNER/OPERATOR .....	2 - 4
BUSH HOG LIMITED WARRANTY .....	2 - 5
<b>ASSEMBLY SECTION.....</b>	<b>3 - 1</b>
DELIVERY AND ASSEMBLY .....	3 - 2
Unpacking the Machine .....	3 - 2
GENERAL ASSEMBLY .....	3 - 3
SUPPORT AND WHEEL ASSEMBLY .....	3 - 3
ASSEMBLY STEPS .....	3 - 5
ASSEMBLY STEPS FOR HYDRAULIC KIT .....	3 - 11
HYDRAULIC TILT KIT ASSEMBLY .....	3 - 14
HAY TEDDER ADJUSTMENTS .....	3 - 17
<b>OPERATION SECTION .....</b>	<b>4 - 1</b>
STANDARD EQUIPMENT AND SPECIFICATIONS .....	4 - 3
OPERATOR REQUIREMENTS .....	4 - 4
TRACTOR REQUIREMENTS .....	4 - 5
ROPS and Seat Belt.....	4 - 5
Tractor Horsepower.....	4 - 5
Drawbar - Pull-Type Mower.....	4 - 5
Front End Weight .....	4 - 6
GETTING ON AND OFF THE TRACTOR .....	4 - 6
Boarding the Tractor.....	4 - 6
Dismounting the Tractor .....	4 - 6
STARTING THE TRACTOR .....	4 - 7
CONNECTING THE HAY TEDDER TO THE TRACTOR .....	4 - 8
Connecting the Hay Tedder.....	4 - 8
Safety Tow Chain .....	4 - 9
DRIVELINE ATTACHMENT .....	4 - 9
Driveline Length Check .....	4 - 10
PRE-OPERATION INSPECTION AND SERVICE .....	4 - 11
Tractor Pre-Operation Inspection/Service .....	4 - 11

# Table of Contents

Hay Tedder Pre-Operation Inspection/Service .....	4 - 12
HAY TEDDER PRE-OPERATION INSPECTION .....	4 - 13
TRACTOR PRE-OPERATION INSPECTION .....	4 - 14
DRIVING THE TRACTOR AND IMPLEMENT .....	4 - 15
Starting the Tractor .....	4 - 16
Brake and Differential Lock Setting .....	4 - 16
Driving the Tractor and Hay Tedder .....	4 - 17
OPERATING THE TRACTOR AND IMPLEMENT .....	4 - 17
Operating the Hay Tedder in the Field (Manual Fold) .....	4 - 18
Adjustment For Correct Working Position .....	4 - 18
PTO RPM and Ground Speed .....	4 - 19
Engaging the Power Take Off (PTO).....	4 - 19
Shutting Down the Implement .....	4 - 19
DISCONNECTING THE HAY TEDDER FROM THE TRACTOR .....	4 - 20
HAY TEDDER STORAGE .....	4 - 21
TRANSPORTING THE TRACTOR AND IMPLEMENT .....	4 - 22
Transport Instructions for Manual Fold.....	4 - 22
Transport Instructions for Hydraulic Fold .....	4 - 23
TRANSPORTING ON PUBLIC ROADWAYS .....	4 - 24
Hauling the Tractor and Implement .....	4 - 26
<b>MAINTENANCE SECTION .....</b>	<b>5 - 1</b>
GENERAL MAINTENANCE.....	5 - 2
LUBRICATION POINTS .....	5 - 3
Driveline Maintenance .....	5 - 4
Driveline Dismantle.....	5 - 4
Driveline Assembly .....	5 - 5
STORAGE .....	5 - 7
SCRAPPING THE MACHINE .....	5 - 7
PROPER TORQUE FOR FASTENERS .....	5 - 7

# **SAFETY SECTION**

Safety Section 1-1

# SAFETY

## SAFETY MESSAGES

A careful operator is the best operator. Safety is of primary importance to the manufacturer and should be to the owner/operator. Most accidents can be avoided by being aware of your equipment, your surroundings, and observing certain precautions. The first section of this manual includes a list of Safety Messages that, if followed, will help protect the operator and bystanders from injury or death. Read and understand these Safety Messages before assembling, operating or servicing this Implement. This equipment should only be operated by those persons who have read the manual, who are responsible and trained, and who know how to do so responsibly.



The Safety Alert Symbol combined with a Signal Word, as seen below, is used throughout this manual and on decals which are attached to the equipment. The Safety Alert Symbol means: "ATTENTION! BECOME ALERT! YOUR SAFETY IS INVOLVED!" The Symbol and Signal Word are intended to warn the owner/operator of impending hazards and the degree of possible injury faced when operating this equipment.

**Practice all usual and customary safe working precautions and above all--remember safety is up to YOU. Only YOU can prevent serious injury or death from unsafe practices.**



Indicates an imminently hazardous situation that, if not avoided, WILL result in DEATH OR VERY SERIOUS INJURY.



Indicates an imminently hazardous situation that, if not avoided, COULD result in DEATH OR SERIOUS INJURY.



Indicates an imminently hazardous situation that, if not avoided, MAY result in MINOR INJURY.

**Important**

Identifies special instructions or procedures that, if not strictly observed, could result in damage to, or destruction of the machine, attachments or the environment.

**NOTE:** *Identifies points of particular interest for more efficient and convenient operation or repair.* (SG-1) str

READ, UNDERSTAND, and FOLLOW the following Safety Messages. Death or serious injury may occur unless care is taken to follow the warnings and instructions stated in the Safety Messages. Always use good common sense to avoid hazards. (SG-2) str



Si no lee ingles, pida ayuda a alguien que si lo lea para que le traduzca las medidas de seguridad. (SG-3) str

**¡ LEA EL INSTRUCTIVO!**



# SAFETY

## DANGER

Never operate the Tractor or Implement until you have read and completely understand this Manual, the Tractor Operator's Manual, and each of the Safety Messages found in the Manual or on the Tractor and Implement. Learn how to stop the tractor engine suddenly in an emergency. Never allow inexperienced or untrained personnel to operate the Tractor or Implement without supervision. Make sure the operator has fully read and understood the manuals prior to operation.

(SG-4)str



## WARNING

The operator and all support personnel should wear hard hats, safety shoes, safety glasses, and proper hearing protection at all times for protection from injury including injury from items that may be thrown by the equipment. (SG-16)str

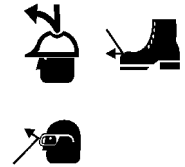

## CAUTION

**PROLONGED EXPOSURE TO LOUD NOISE MAY CAUSE PERMANENT HEARING LOSS!** Tractors with or without an Implement attached can often be noisy enough to cause permanent hearing loss. We recommend that you always wear hearing protection if the noise in the Operator's position exceeds 80db. Noise over 85db over an extended period of time will cause severe hearing loss. Noise over 90db adjacent to the Operator over an extended period of time will cause permanent or total hearing loss.

**NOTE:** *Hearing loss from loud noise [from tractors, chain saws, radios, and other such sources close to the ear] is cumulative over a lifetime without hope of natural recovery.* (SG-17)str



## WARNING

Always read carefully and comply fully with the manufacturer's instructions when handling oil, solvents, cleansers, and any other chemical agent. (SG-22)str



## DANGER

**KEEP AWAY FROM ROTATING ELEMENTS** to prevent entanglement and possible death or serious injury. (SG-24)str



## DANGER

Never allow children to play on or around Tractor or Implement. Children can slip or fall off the Equipment and be killed or injured. Inadvertent contact with controls can cause the Implement to shift or fall crushing themselves or others. (SG-25)str

SAFETY

# SAFETY

**⚠ DANGER**

DO NOT use drugs or alcohol immediately before or while operating the Tractor and Implement. Drugs and alcohol will affect an operator's alertness and coordination and therefore affect the operator's ability to operate the equipment safely. Before operating the Tractor or Implement, an operator on prescription or over-the-counter medication must consult a medical professional regarding any side effects of the medication that would hinder their ability to operate the Equipment safely. NEVER knowingly allow anyone to operate this equipment when their alertness or coordination is impaired. Serious injury or death to the operator or others could result if the operator is under the influence of drugs or alcohol.

(SG-27) str

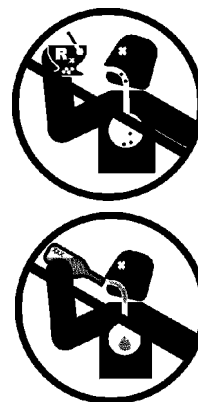

**⚠ WARNING**

Prolonged operation may cause operator boredom and fatigue affecting safe operation. Take scheduled work breaks to help prevent these potentially impaired operating conditions. Never operate the Implement and Tractor in a fatigued or bored mental state which impairs proper and safe operation. (SG-32) str

**⚠ WARNING**

Use extreme caution when getting onto the Implement to perform repairs, maintenance and when removing accumulated material. Only stand on solid flat surfaces to ensure good footing. Use a ladder or raised stand to access high spots which cannot be reached from ground level. Slipping and falling can cause serious injury or death.

(SG-33) str

**⚠ DANGER**

DO NOT operate this Implement on a Tractor that is not properly maintained. Should a mechanical or Tractor control failure occur while operating, immediately shut down the Tractor and perform repairs before resuming operation. Serious injury and possible death could occur from not maintaining this Implement and Tractor in good operating condition.

(SG-36) str

**⚠ WARNING**

Extreme caution should be used by the Tractor operator when operating near passersby. Stop raking if anyone comes within 25 feet of the Implement to prevent possible passerby injury or death from being struck from a thrown object, entanglement with the rakes, or run over. (SRK-01) str



# SAFETY

## EQUIPMENT OPERATION SAFETY INSTRUCTIONS AND PRACTICES

### **▲ WARNING**

Never leave the Tractor and Implement unattended while the Implement is in the lifted position. Accidental operation of lifting lever or a hydraulic failure may cause sudden drop of unit with injury or death by crushing. To properly park the implement when disconnecting it from the tractor, lower the stand and put the retaining pin securely in place, or put a secure support under the A-Frame. Lower the implement carefully to the ground. Do not put hands or feet under lifted components. (S3PT-01) str

### **▲ CAUTION**

Do not back up with this implement. Backing could damage the machine or its components. (S3PT-04) sstr

### **▲ WARNING**

Use extreme care when lowering or unfolding the implement's wings. Make sure no bystanders are close by or underneath the wings. Allow ample clearance around the implement when folding or unfolding the wings. Use extreme caution around buildings or overhead power lines. (S3PT-05) str

### **▲ DANGER**

There are obvious and hidden potential hazards in the operation of this implement as in all power-driven or pulled equipment. REMEMBER! This machine is often operated in rough terrain conditions that include tall grass, weeds, gullies, holes, slopes, hidden obstructions and the like. Serious injury or even death may occur unless care is taken to assure the safety of the operator and bystanders in the area. Do not operate this machine with anyone in the immediate area. (S3PT-07) str

### **▲ DANGER**

This Implement may be wider than the Tractor. Be careful when operating or transporting this equipment to prevent the Implement from running into or striking sign posts, guard rails, concrete abutments or other solid objects. Such an impact could cause the Implement and Tractor to pivot violently resulting in loss of steering control, death, or serious injury. Never allow the Implement to contact obstacles. (S3PT-12)str

### **▲ WARNING**

Operate this Implement only in conditions where you have clear visibility in daylight or with adequate artificial lighting. Never operate in darkness or foggy conditions where you cannot clearly see at least 100 yards in front and to the sides of the tractor and implement. Make sure that you can clearly see and identify passersby, steep slopes, ditches, drop-offs, overhead obstructions, power lines, debris and foreign objects. If you are unable to clearly see these types of items discontinue operating this equipment. (S3PT-21) str

### **▲ WARNING**

Operate this Equipment only with a Tractor equipped with an approved roll-over-protective system (ROPS). Always wear seat belts. Death or serious injury could result from falling off the tractor, particularly during a turnover when the operator could be pinned under the ROPS. (SG-7) str



### **▲ WARNING**

Do not modify or alter this Implement. Do not permit anyone to modify or alter this Implement, any of its components or any Implement function. (SG-8)str

# SAFETY

**DANGER**

BEFORE leaving the tractor seat lower the implement, set the parking brake and/or set the tractor transmission in parking gear, disengage the PTO, stop the engine, remove the key, and wait for all moving parts to stop. Place the tractor shift lever into a low range or parking gear to prevent the tractor from rolling. Never dismount a Tractor that is moving or while the engine is running. Operate the Tractor controls from the tractor seat only.

(SG-9)str

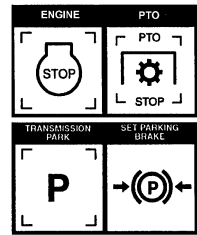

**DANGER**

Never allow children or other persons to ride on the Tractor or Implement. Falling off can result in death or serious injury. (SG-10)str



**DANGER**

Never allow children to operate, ride on, or come close to the Tractor or Implement. Usually, 16-17 year-old children who are mature and responsible can operate the implement with adult supervision, if they have read and understand the Operator's Manuals, been trained in proper operation of the tractor and Implement, and are physically large enough to reach and operate the controls easily. (SG-11) str



**WARNING**

Do not mount or dismount the Tractor while the tractor is moving. Mount the Tractor only when the Tractor and all moving parts are completely stopped. Dismounting a moving power unit can result in a crushing hazard that can cause death or serious injury. (SG-12) str



**DANGER**

Start tractor only when properly seated in the Tractor seat. Starting a tractor in gear can result in death or serious injury. Read the Tractor operators manual for proper starting instructions. (SG-13) str



**WARNING**

Do not operate this Equipment with hydraulic oil or fuel leaking. Oil and fuel are explosive and their presence could present a hazard. Do not check for leaks with your hand! High-pressure oil streams from breaks in the line could penetrate the skin and cause tissue damage including gangrene. To check for a hose leak, SHUT the unit ENGINE OFF and remove all hydraulic pressure. Wear oil impenetrable gloves, safety glasses and use cardboard to check for evidence of oil leaks. If you suspect a leak, REMOVE the HOSE and have it tested at a Dealer. If oil does penetrate the skin, have the injury treated immediately by a physician knowledgeable and skilled in this procedure. (SG-15) str



# SAFETY



**DANGER**

Never run the Tractor engine in a closed building or without adequate ventilation. The exhaust fumes can be hazardous to your health. (SG-23) str



**WARNING**

Do not exceed the rated PTO speed for the Implement. Excessive PTO speeds can cause Implement driveline or component failures resulting in serious injury or death. (SG-26) str



**DANGER**

Operate the Tractor and/or Implement controls only while properly seated in the Tractor seat with the seat belt securely fastened around you. Inadvertent movement of the Tractor or Implement may cause death or serious injury. (SG-29)str



**WARNING**

In case of mechanical difficulty during operation, place the transmission in the park position, set the parking brake, shut down all power, including the PTO and the engine and remove the key. Wait until all rotating motion has stopped before dismounting. (SG-39) str



**WARNING**

Do Not operate this equipment in areas where insects such as bees, may attack you and/or cause you to lose control of the equipment. If you must enter into such areas, use a tractor with an enclosed Cab and close the windows to prevent insects from entering. If a tractor cab is not available, wear suitable clothing including head, face, and hand protection to shield you from insects. Attacking insects can cause you to lose control of the tractor, which can result in serious injury or death to you or bystanders. Never dismount a moving tractor. (SG-40) str



**WARNING**

Objects such as wire, cable, rope, and chain can become entangled in the rotating parts of the raking components causing mechanical damage. Entangled items caught in the rakes can sling outwards possibly injuring or entangling the operator or passersby. Any objects that might become entangled in a raking component should be removed from the area before operating the rake. (SRK-02) str



**DANGER**

**DO NOT** allow any person under a folded wing unless the wing is securely locked up or supported. **DO NOT** approach the Implement unless the Tractor is turned off and all motion has ceased. Never work under the frame work, or any lifted component unless the implement is securely supported or blocked up. A sudden or inadvertent fall by any of these components could cause serious injury or even death. (STI-03) str



**SAFETY**

# SAFETY

## CONNECTING OR DISCONNECTING IMPLEMENT SAFETY INSTRUCTIONS AND PRACTICES

### **WARNING**

The rotating parts of this machine continue to rotate even after the PTO has been turned off. The operator should remain in the operator's seat for 60 seconds after the brake has been set, the PTO disengaged, the tractor turned off, and all evidence of rotation has ceased. (S3PT-10) str  
**“Wait a minute. . . Save a life!”**

### **DANGER**

**DO NOT** use a PTO adapter to attach a non-matching Implement driveline to a Tractor PTO. Use of an adapter can double the operating speed of the Implement resulting in excessive vibration, thrown objects, and blade and implement failure. Adapter use will also change the working length of the driveline exposing unshielded driveline areas. Serious bodily injury and/or equipment failure can result from using a PTO adapter. Consult an authorized dealer for assistance if the Implement driveline does not match the Tractor PTO. (S3PT-14) str

### **DANGER**

Always shut the Tractor completely down, place the transmission in park, and set the parking brake before you or anyone else attempts to connect or disconnect the Implement and Tractor hitches. (S3PT-15) str

### **WARNING**

When attaching the Implement input driveline to the Tractor PTO, it is important that the connecting yoke spring activated locking collar slides freely and the locking balls are seated securely in the groove on the Tractor PTO shaft. Push and pull the driveline back and forth several times to ensure it is securely attached. A driveline not attached correctly to the Tractor PTO shaft could come loose and result in personal injury and damage to the Implement. (S3PT-17 str)

### **WARNING**

Before operating the Implement, check to make sure the Implement input driveline will not bottom out or become disengaged. Bottoming out occurs when the inner shaft penetrates the outer housing until the assembly becomes solid-it can shorten no more. Bottoming out can cause serious damage to the Tractor PTO by pushing the PTO into the Tractor and through the support bearings or downward onto the PTO shaft, breaking it off. A broken driveline can cause personal injury. (S3PT-18 str)

### **WARNING**

Never unhitch without using the Tongue Jack. The Tongue is very heavy. Attempting to lift the Tongue without using the Tongue Jack could cause strains or other injury. Allowing the tongue to fall suddenly and unexpectedly could result in crushing injury. Use the Tongue Jack for lifting the Implement only. Overloading the Tongue Jack can cause failure with possible serious bodily injury or even death. (STI-04) str

### **CAUTION**

On a fully assembled unit, do not remove the Wing Retaining Strap until hoses are attached to the tractor and the Wing Cylinders are filled with oil. Lower the Wings slowly and carefully. Keep bystanders away during operations. (STI-05) str

# SAFETY

## TRANSPORTING SAFETY INSTRUCTIONS AND PRACTICES



**WARNING** Be particularly careful when transporting the Implement with the Tractor. Turn curves or go up hills only at a low speed and using a gradual steering angle. Rear mounted implements move the center of gravity to the rear and remove weight from the front wheels. Make certain, by adding front ballast, that at least 20% of the tractor's weight is on the front wheels to prevent rearing up, loss of steering control or Tractor tip-over. Slow down on rough or uneven surfaces to prevent loss of steering control which could result in property damage or possible injury. Do not transport unless 3-Point lift lever is fully raised and in the latched transport position. Dropping implement in transport can cause serious damage to the tractor and/or Implement and possibly cause the operator or others to be killed or injured. (S3PT-02)str



**WARNING** Allow sufficient clearance for the Implement to swing outward while turning. Implements carried behind the Tractor will swing outside the tire path when making turns. Contacting a solid object while turning will cause equipment damage and possible injury. (S3PT-20) str



**WARNING** Make certain that the "Slow Moving Vehicle" (SMV) sign is installed in such a way as to be clearly visible and legible. When transporting the Equipment use the Tractor flashing warning lights and follow all local traffic regulations. (SG-6)str

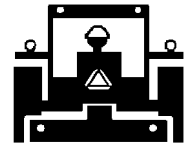

**WARNING** Transport only at speeds where you can maintain control of the equipment. Serious accidents and injuries can result from operating this equipment at high speeds. Understand the Tractor and Implement and how it handles before transporting on streets and highways. Make sure the Tractor steering and brakes are in good condition and operate properly.



Before transporting the Tractor and Implement, determine the proper transport speeds for you and the equipment. Make sure you abide by the following rules:

Test the tractor at a slow speed and increase the speed slowly. Apply the Brakes smoothly to determine the stopping characteristics of the Tractor and Implement. As you increase the speed of the Tractor the stopping distance increases. Determine the maximum transport speed not to exceed 20 mph (30 kph) for transporting this equipment.

Test the equipment at a slow speed in turns. Increase the speed through the turn only after you determine that the equipment can be operated at a higher speed. Use extreme care and reduce your speed when turning sharply to prevent the tractor and implement from turning over. Determine the maximum turning speed for you and this equipment before operating on roads or uneven ground.

Only transport the Tractor and Implement at the speeds which allow you to properly control the equipment.

Be aware of the operating conditions. Do not operate the Tractor with weak or faulty brakes or worn tires. When operating down a hill or on wet or rain slick roads, the braking distance increases: use extreme care and reduce your speed. When operating in traffic always use the Tractor's flashing warning lights and reduce your speed. Be aware of traffic around you and watch out for the other guy. (SG-19)str



**DANGER** Be particularly careful when transporting the Implement using the tractor. Turn curves or go up or down hills only at a low speed and at a gradual steering angle. Make certain that at least 20% of the tractor's weight is on the front wheels to maintain safe steering. Slow down on rough or uneven surfaces. (STI-01) str

# SAFETY

**⚠ DANGER**

When the Wings are folded for transport, the center of gravity is raised and the possibility of overturn is increased. Drive slowly and use extreme caution when turning on hillsides. Overturning the Implement could cause the Implement to overturn the Tractor and vice versa resulting in serious injury or even death. Never fold wings on a hillside...the Implement or unit may overturn. (STI-02) str

**⚠ WARNING**

Only tow the Implement behind a properly sized and equipped Tractor which exceeds the weight of the Implement by at least 20%. DO NOT tow the Implement behind a truck or other type of vehicle. Never tow the Implement and another Implement connected in tandem. Never tow the Implement at speeds over 20 MPH. (STI-06)str



**⚠ WARNING**

Secure the Implement for transport before traveling on public roads. For pull-type Implements, secure the center axle using cylinder stops or transport pin and properly attach a safety chain between the Implement and Tractor. Secure wings in upright position on folding Implements using wing transport locks. (STI-7) str

**⚠ WARNING**

Always keep a careful lookout and use extreme care when working around overhead obstructions and electrical power lines. The Implement wing can be over 10 feet high. Never allow the Implement wing to come within 10 feet of any power line. (STI-8) str



**⚠ WARNING**

Your driving vision may be reduced or impaired by the tractor, cab, or implement. Before driving on public roadways identify any limited vision areas, and make adjustments to your operating position, mirrors, and the implement transport position so that you can clearly see the area where you will be traveling, and any traffic that may approach you. Failure to maintain adequate vision of the public roadway and traffic can result in serious injury or even death. (STI-10)

## MAINTENANCE AND SERVICE SAFETY INSTRUCTIONS AND PRACTICES

**⚠ DANGER**

Make sure the PTO shield, integral driveline shields, and input shields are installed when using PTO-driven equipment. Always replace any shield if it is damaged or missing. (S3PT-8) str



**⚠ WARNING**

Relieve hydraulic pressure prior to doing any maintenance or repair work on the Implement. Place the Implement on the ground or securely blocked up, disengage the PTO, and turn off the tractor engine. Push and pull the Remote Cylinder lever in and out several times prior to starting any maintenance or repair work. (S3PT-09)str



**⚠ DANGER**

Always disconnect the main PTO Driveline from the Tractor before performing service on the Implement. Never work on the Implement with the tractor PTO driveline connected and running. Rotating Parts, Blades or Drivelines could turn without warning and cause immediate entanglement, injury or death. (S3PT-11)str

**⚠ WARNING**

Keep fingers clear of adjusting holes. A sudden movement could cause injury or even amputate fingers. KEEP CHILDREN AWAY WHEN MAKING ADJUSTMENTS. (SBL-3)str

**⚠ WARNING**

Always maintain the safety signs in good readable condition. If the safety signs are missing, damaged, or unreadable, obtain and install replacement safety signs immediately. (SG-5)str

# SAFETY



**WARNING**

Do not modify or alter this Implement. Do not permit anyone to modify or alter this Implement, any of its components or any Implement function. (SG-8)str



**DANGER**

Never work under the Implement, the framework, or any lifted component unless the Implement is securely supported or blocked up to prevent sudden or inadvertent falling which could cause death or serious injury. (SG-14)str

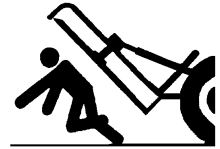

**WARNING**

Never attempt to lubricate, adjust, or remove material from the Implement while it is in motion or while tractor engine is running. (SG-20)str



**WARNING**

Periodically inspect all moving parts for wear and replace when necessary with authorized service parts. Look for loose fasteners, worn or broken parts, and leaky or loose fittings. Make sure all pins have cotter pins and washers. Serious injury may occur from not maintaining this machine in good working order. (SG-21)str

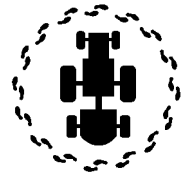

**WARNING**

Perform service, repairs and lubrication according to the maintenance section. Ensure the unit is properly lubricated as specified in the lubrication schedule and all bolts and nuts are properly torqued. Failure to properly service, repair and maintain this Implement in good operating condition could cause component failure and possible serious injury or even death. (SG-35)str



**WARNING**

Use caution and wear protective gloves when handling sharp objects such as blades, knives, and other cutting edges. Be alert to worn component sharp surfaces which have sharp edges. Sharp surfaces can inflict severe laceration injuries if proper hand protection is not worn. (SG-37)str



**WARNING**

Cancer and Reproductive Harm [www.P65Warnings.ca.gov](http://www.P65Warnings.ca.gov)

SAFETY

# SAFETY

## PARTS INFORMATION

Bush Hog products are designed utilizing specifically matched system components to ensure optimum equipment performance. These parts are made and tested to Bush Hog specifications. Non-genuine "will fit" parts do not consistently meet these specifications. The use of "will fit" parts may reduce equipment performance, void warranties, and present a safety hazard. Use genuine Bush Hog parts for economy and safety. (SPBH-2)str

SEE YOUR BUSH HOG DEALER

## Storage and Parking Safety Instructions and Practices



A rear Implement can fall if not properly supported. Always use the stand on the front hitch (if equipped) or block up securely to prevent falling and possible crushing injury and/or other injury from holding or lifting heavy components. Use the stand to stabilize the implement during storage. (S3PT-3) str



To prevent tipping of Implement when stored in folded position, use carrying wheels or adequate stands on center frame. (S3PT-6) str

## Concluding Safety Instructions and Practices

In addition to the design and configuration of this Implement, including Safety Signs and Safety Equipment, hazard control and accident prevention are dependent upon the awareness, concern, prudence, and proper training of personnel involved in the operation, transport, maintenance, and storage of the machine. Refer also to Safety Messages and operation instruction in each of the appropriate sections of the Tractor and Equipment Manuals. Pay close attention to the Safety Signs affixed to the Tractor and Equipment. (SG-18)str

## DECAL LOCATION

**NOTE:** Bush Hog supplies safety decals on this product to promote safe operation. Damage to the decals may occur while in shipping, use, or reconditioning. Bush Hog cares about the safety of its customers, operators, and bystanders, and will replace the safety decals on this product in the field, free of charge (Some shipping and handling charges may apply). Contact your Bush Hog dealer to order replacement decals.



# SAFETY

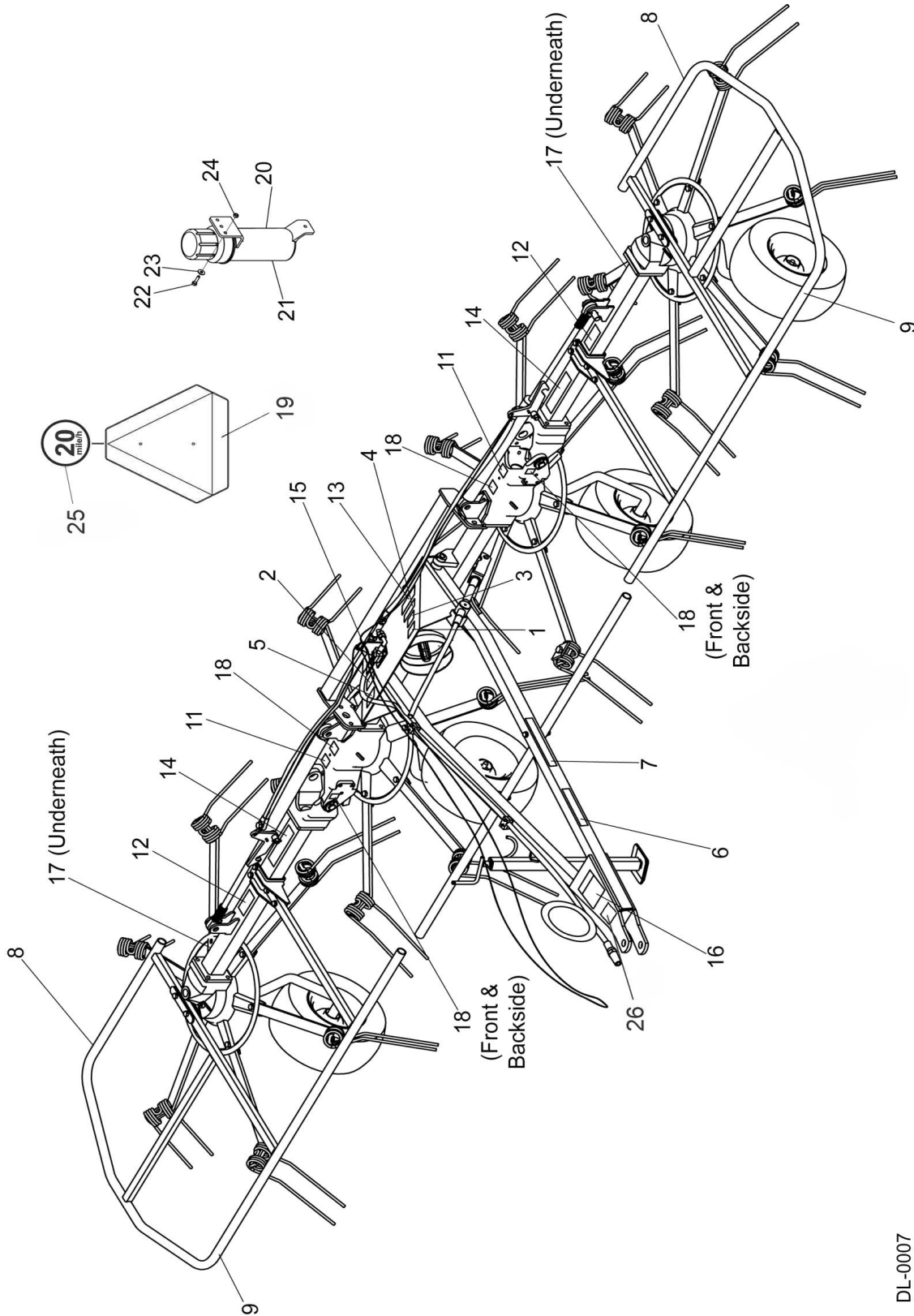

**SAFETY**

DL-0007

# SAFETY

**SAFETY**

ITEM	PART NO.	QTY	TYPE	DESCRIPTION
1.	999001	1	WARNING	Maintain Weight for Steerage
2.	00725746	1	PELIGRO	Spanish - Get Translation
3.	00763977	1	INSTRUCT	Notice to Owner
4.	999200	1	WARNING	Multi-Hazard
5.	D859	1	WARNING	Use Genuine Bush Hog Parts
6.	50063360	2	LOGO	Bush Hog
7.	50068924	2	NAME	HT417 Model
	50068925	2	NAME	HT417H Model
8.	2738332	2	REFLECT	Red Reflector
9.	2738333	2	REFLECT	Yellow Reflector
10.	NFS	1	SERIAL PLT	Serial Number Plate
11.	D623	2	WARNING	Pinch Points
12.	3678303	2	DANGER	Keep Clear of Rotor
13.	D910	1	WARNING	Towing Hazard
14.	52740	2	WARNING	Leak Detection (HT417H)
15.	D544	1	IMPORTANT	Transport Latch
16.	D635	1	WARNING	540 RPM
17.	D555	2	DANGER	Crushing Hazard
18.	001.075	6	INSTRUCT	Label, Grease
19.	94359	1	REFLECT	SMV
20.	50068961	1	---	Operator's Manual
21.	50035829	1	---	Canister, Operator's manual
22.		3	---	Bolt
23.		3	---	Flatwasher
24.		3	---	Locknut
25.	50082007	1	IMPORTANT	20 MPH Speed
26.	D1085	1	NOTICE	Park on Level Ground Max 10% Ground Slope

# SAFETY

## DECAL DESCRIPTION

**⚠ WARNING**

**To avoid serious injury or machine damage:**

- ALWAYS MAINTAIN 20% of tractor weight on front wheels. Add weight to front if needed.
- REDUCE SPEED on inclines, in turns and in poor weather conditions.
- DO NOT lift implement while on steep slopes.
- DO NOT start or accelerate suddenly. 999001



**⚠ PELIGRO**

**LEA EL INSTRUCTIVO**

Si No Lee Ingles, Pida Ayuda a Alguien Que Si Lo Lea Para Que le Traduzca las Medidas de Seguridad.



00725746

**⚠ WARNING**

**AVOID PINCH POINTS THAT CAN RESULT IN SERIOUS INJURY**

D623



**⚠ WARNING**

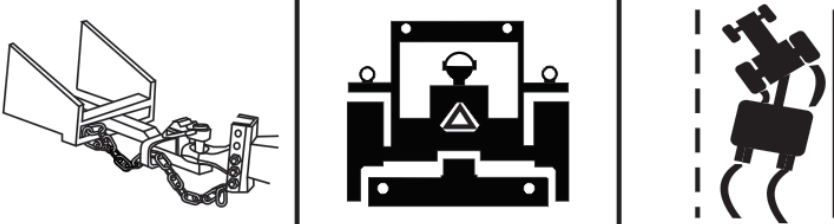

**TO AVOID DEATH OR SERIOUS INJURY WHEN TOWING EQUIPMENT:**

- DO NOT TOW with trucks or other vehicles.
- ONLY transport with properly sized and equipped tractor. (see Operator's Manual)
- ATTACH implement SAFETY CHAIN to tractor.
- CHECK SMV sign, reflectors and warning lights for visibility behind unit.
- TURN ON tractor flashing warning lights.

**TO AVOID LOSS OF TOWING CONTROL:**

- DO NOT tow at speeds over 20 mph.
- REDUCE SPEED on inclines, in turns and in poor towing conditions. D910

SAFETY

# SAFETY

SAFETY

**⚠ WARNING**

**TO AVOID DEATH OR SERIOUS INJURY:**

- ONLY use genuine Bush Hog replacement parts, which have been validated and tested to use on Bush Hog equipment by the manufacturer.
- The equipment manufacturer cannot verify the material or structural integrity of third-party supplied non-genuine replacement parts.
- Using non-genuine parts can result in the part failing, creating hazardous conditions for operator and bystanders.

Contact local dealer or Bush Hog about repair parts at:  
2501 Griffin Ave., Selma, AL 36701  
Customer Service: 800-363-6096.  
Email: [contactus@bushhog.com](mailto:contactus@bushhog.com) [www.algqr.com/bpm](http://www.algqr.com/bpm)



**⚠ WARNING**

**Cancer and Reproductive Harm**  
[www.P65Warnings.ca.gov](http://www.P65Warnings.ca.gov) D859

**⚠ DANGER**



**Crushing Hazard**

**Transport Latch**  
RAISE AND SECURELY LOCK Wing Transport Latch before transporting mower on roadways or working under wing. D555

**⚠ DANGER**



**KEEP CLEAR OF ROTORS**  
Death or Serious Injury may result from entanglement. Disengage PTO & shut off tractor if bystanders enter area or before servicing. 3678303



**⚠ WARNING**

**TO AVOID SERIOUS INJURY OR DEATH:**

1. READ AND UNDERSTAND OPERATOR'S MANUAL.
2. TRACTOR MUST BE EQUIPPED WITH ROLL-OVER PROTECTION (ROPS) AND SWAY CHAINS.
3. ALWAYS WEAR SAFETY GLASSES, SAFETY SHOES AND SEAT BELT FASTENED TIGHTLY.
4. STOP TRACTOR, LOCK BRAKES, AND BLOCK UP OR SUPPORT IMPLEMENT SECURELY BEFORE WORKING UNDER RAISED COMPONENTS.
5. ALLOW NO RIDERS AT ANY TIME ON TRACTOR OR IMPLEMENT. FALLING OFF CAN KILL.
6. KEEP BYSTANDERS CLEAR OF MOVING PARTS AND WORKING AREA. KEEP CHILDREN AWAY!
7. DO NOT LIFT, LOWER, OR OPERATE UNLESS EVERYONE IS CLEAR OF IMPLEMENT.
8. USE INCREASED CAUTION ON SLOPES & NEAR BANKS AND DITCHES TO PREVENT OVERTURN.
9. LOCK LIFT LEVER UP FOR TRANSPORT. HAVE SMV SIGN VISIBLE. FOLLOW LOCAL LAWS.
10. USE PARKING STAND OR BLOCK UP WHEN UNHITCHING FROM TRACTOR.

999200

# SAFETY

SAFETY

**⚠ WARNING**

**DO NOT OPERATE WITH OIL LEAKS**

Inspect hoses regularly. Failure to inspect and replace worn hoses may allow them to rupture **suddenly** and **violently** resulting in death or serious bodily injury from scalding, fire burn injury or oil penetration.

 Frayed, torn, or crimped hoses may **rupture** and spray **hot oil** on operator causing serious **scalding injury**.

Oil may spray on **hot tractor parts** and catch fire resulting in **death, severe injury** or burns.

 To check for hose leak, shut tractor off and remove hydraulic pressure. **Never use hands** to check for leaks.

Wear safety glasses with side shields (marked to comply with ANSI Z87), oil impenetrable gloves, and use cardboard to check for evidence of oil leaks. If you suspect a leak, **remove the hose** and have it tested at a dealer.

**KEEP SHIELDS IN PLACE OVER HYDRAULIC COMPONENTS**

 Do not operate equipment if shields are missing or if oil leaks exist.

Repair or replace hoses as needed to prevent unexpected failure and possible serious injury to operator or bystander. If oil penetrates skin, serious injury or gangrene could occur. **A doctor familiar with this type of injury must surgically remove the injected fluid immediately.** 52740

**IMPORTANT**

An OPERATOR'S MANUAL was attached to this implement during assembly. If they were not attached at the time of purchase, please contact your selling dealer at once.

- Read and understand the Operator's Manual before operating this implement.

00763977

**IMPORTANT**

**TRANSPORT LATCH**  
Securely lock Transport Latch before transporting mower on roadway or working under implement.

D544

**NOTICE**

Do not tow at speeds greater than 20 MPH(30 KM/H).  
Ensure mass of towing vehicle is at least 2/3 times the mass of the towed machinery.  
Be sure to park on level ground to a maximum of 10% ground slope. D1085

**⚠ WARNING**

OPERATE THIS MACHINE AT  
**540 RPM**  
TRACTOR PTO SPEED ONLY.  
Overspeeding PTO may cause component failure resulting in bodily injury.  
TRACTOR PTO ROTATION: CLOCKWISE

 D635

# SAFETY

## FEDERAL LAWS AND REGULATIONS

This section is intended to explain in broad terms the concept and effect of federal laws and regulations concerning employer and employee equipment operators. This section is not intended as a legal interpretation of the law and should not be considered as such.

### **Employer-Employee Operator Regulations**

U.S. Public Law 91-596 (The Williams-Steiger Occupational and Health Act of 1970) OSHA

#### **This Act Seeks:**

“...to assure so far as possible every working man and woman in the nation safe and healthful working conditions and to preserve our human resources...”

#### **DUTIES**

Sec. 5 (a) Each employer-

(1) shall furnish to each of his employees employment and a place of employment which are free from recognized hazards that are causing or are likely to cause death or serious physical harm to his employees;

(2) shall comply with occupational safety and health standards promulgated under this Act.

(b) Each employee shall comply with occupational safety and health standards and all rules, regulations and orders issued pursuant to this Act which are applicable to his own actions and conduct.

### **OSHA Training Requirements**

***Title 29, Code of Federal Regulations Part 1928.57(a)(6).*** [www.osha.gov](http://www.osha.gov)

Operator instructions. At the time of initial assignment and at least annually thereafter, the employer shall instruct every employee who operates an agricultural tractor and implements in the safe operating practices and servicing of equipment with which they are or will be involved, and of any other practices dictated by the work environment.

Keep all guards in place when the machine is in operation.

Permit no riders on equipment.

Stop engine, disconnect the power source, and wait for all machine movement to stop before servicing, adjusting, cleaning or unclogging the equipment, except where the machine must be running to be properly serviced or maintained, in which case the employer shall instruct employees as to all steps and procedures which are necessary to safely service or maintain the equipment.

Make sure everyone is clear of machinery before starting the engine, engaging power, or operating the machine.

### **Employer Responsibilities:**

To ensure employee safety during Tractor and Implement operation, it is the employer's responsibility to:

1. Train the employee in the proper and safe operation of the Tractor and Implement.
2. Require that the employee read and fully understand the Tractor and Implement Operator's Manual.
3. Permit only qualified and properly trained employees to operate the Tractor and Implement.
4. Maintain the Tractor and Implement in a safe operational condition and maintain all shields and guards on the equipment.
5. Ensure the Tractor is equipped with a functional ROPS and seat belt and require that the employee operator securely fasten the safety belt and operate with the ROPS in the raised position at all times.
6. Forbid the employee operator to carry additional riders on the Tractor or Implement.
7. Provide the required tools to maintain the Tractor and Implement in a good safe working condition and provide the necessary support devices to secure the equipment safely while performing repairs and service.
8. Require that the employee operator stop operation if bystanders or passersby come within 300 feet.

### **Child Labor Under 16 Years of Age**

Some regulations specify that no one under the age of 16 may operate power machinery. It is your responsibility to know what these regulations are in your own area or situation. (Refer to U.S. Dept. of Labor, Employment Standard Administration, Wage & Home Division, Child Labor Bulletin #102.)

# **INTRODUCTION SECTION**

Introduction Section 2-1

# INTRODUCTION

INTRODUCTION

## PRODUCT IDENTIFICATION

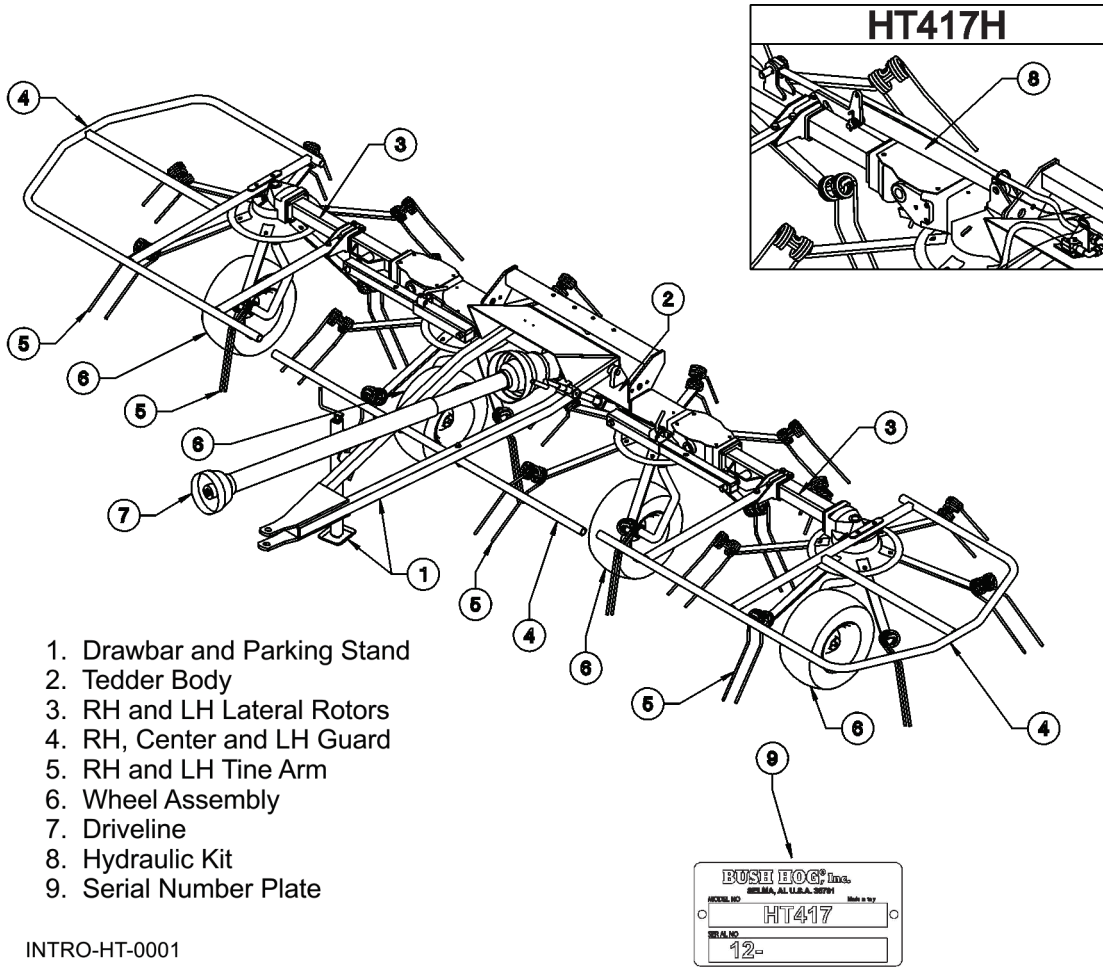

1. Drawbar and Parking Stand
2. Tedder Body
3. RH and LH Lateral Rotors
4. RH, Center and LH Guard
5. RH and LH Tine Arm
6. Wheel Assembly
7. Driveline
8. Hydraulic Kit
9. Serial Number Plate

INTRO-HT-0001

SPECIFICATION	HT417 Manual Fold	HT417H Hydraulic Fold
<b>Number of Rotors</b>	4	4
<b>Tine Arms per Rotor</b>	6	6
<b>Working Width</b>	17' (5.20m)	17' (5.20m)
<b>Transport Width</b>	10'-3" (3.15m)	10'-3" (3.15m)
<b>Weight</b>	1014 lbs (460 kg)	1047 lbs (475 kg)
<b>Tire Size</b>	16 x 6.50-8	16 x 6.50-8
<b>PTO Tractor Requirement</b>	25 HP (18 kw)	25 HP (18 kw)
<b>PTO Slip Clutch</b>	Standard	Standard
<b>Operating Speed</b>	10 mph (16 Km/h)	10 mph (16 Km/h)

All data is indicative. Bush Hog reserves the right to change, without advance notice.

HT417/HT417H 08/22

Introduction Section 2-2



# INTRODUCTION

The HT417/HT417H Hay Tedder is one of the fastest and most efficient hay tedders available. Rotor speed and forward drive speed should be selected for each individual job, since there are large variations in the nature and properties of different crops.

This HT417/HT417H Hay Tedder is designed with care and built with quality materials by skilled workers. Proper assembly, maintenance, and operating practices, as described in this manual, will help the owner/operator get years of satisfactory service from the machine.

The purpose of this manual is to familiarize, instruct, and train. The Assembly Section instructs the owner/operator in the correct assembly of the tedder using standard and optional equipment.

Careful use and timely service saves extensive repairs and costly down time losses. The Operation and Maintenance sections of the manual trains the owner/operator how to work the tedder correctly and attend to appropriate maintenance.

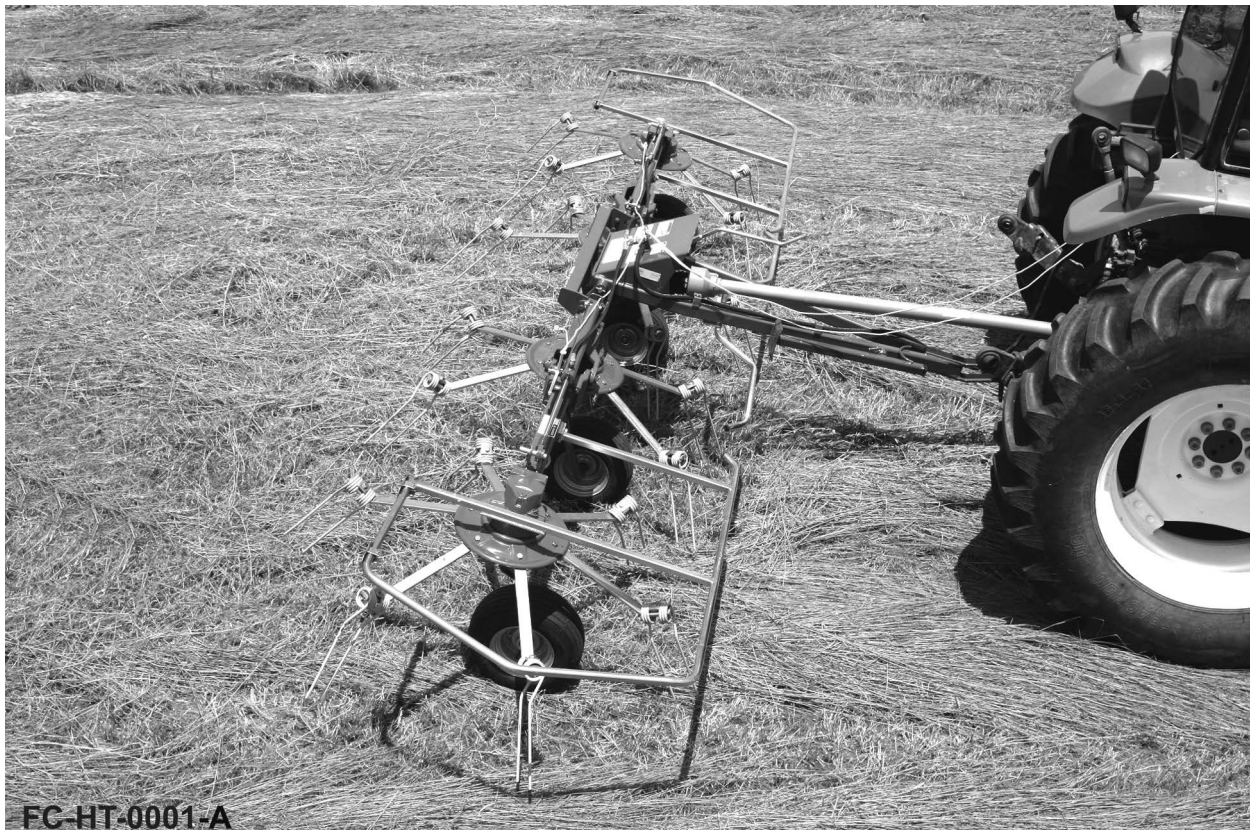

INTRODUCTION

# INTRODUCTION

## **ATTENTION OWNER/OPERATOR**

BEFORE OPERATING THIS MACHINE:

1. Carefully read the Operator's Manual, completely understand the Safety Messages and instructions, and know how to operate correctly both the tractor and implement.
2. Fill out the Warranty Card in full. Be sure to answer all questions, including the Serial Number of the implement. Mail within 30 days of delivery date of this implement.

**NOTE:** Warranties are honored only if completed "Owner Registration and Warranty" forms are received by Bush Hog within thirty days of delivery of the implement.

3. Record the Implement Model and Serial Numbers on the Warranty page at the front of the Operator's Manual. Keep this as part of the permanent maintenance file for the implement.

**⚠ WARNING**

**TO AVOID DEATH OR SERIOUS INJURY:**

- ONLY use genuine Bush Hog replacement parts, which have been validated and tested to use on Bush Hog equipment by the manufacturer.
- The equipment manufacturer cannot verify the material or structural integrity of third-party supplied non-genuine replacement parts.
- Using non-genuine parts can result in the part failing, creating hazardous conditions for operator and bystanders.

Contact local dealer or Bush Hog about repair parts at:  
2501 Griffin Ave., Selma, AL 36701  
Customer Service: 800-363-6096.  
Email: [contactus@bushhog.com](mailto:contactus@bushhog.com) [www.algqr.com/bpm](http://www.algqr.com/bpm)



**⚠ WARNING**

**Cancer and Reproductive Harm**  
[www.P65 Warnings.ca.gov](http://www.P65Warnings.ca.gov) D859

# INTRODUCTION

## BUSH HOG LIMITED WARRANTY



INTRODUCTION

Bush Hog warrants to the original purchaser of any new Bush Hog equipment, purchased from an authorized Bush Hog dealer, that the equipment be free from defects in material and workmanship for a period of one (1) year for non-commercial, state and municipalities' use and ninety (90) days for commercial use from date of retail sale. The obligation of Bush Hog to the purchaser under this warranty is limited to the repair or replacement of defective parts.

Replacement or repair parts installed in the equipment covered by this limited warranty are warranted for ninety (90) days from the date of purchase of such part or to the expiration of the applicable new equipment warranty period, whichever occurs later. Warranted parts shall be provided at no cost to the user at an authorized Bush Hog dealer during regular working hours. Bush Hog reserves the right to inspect any equipment or parts which are claimed to have been defective in material or workmanship.

### DISCLAIMER OF IMPLIED WARRANTIES & CONSEQUENTIAL DAMAGES

Bush Hog's obligation under this limited warranty, to the extent allowed by law, is in lieu of all warranties, implied or expressed, **INCLUDING IMPLIED WARRANTIES OF MERCHANTABILITY AND FITNESS FOR A PARTICULAR PURPOSE** and any liability for incidental and consequential damages with respect to the sale or use of the items warranted. Such incidental and consequential damages shall include but not be limited to: transportation charges other than normal freight charges; cost of installation other than cost approved by Bush Hog; duty; taxes; charges for normal service or adjustment; loss of crops or any other loss of income; rental of substitute equipment, expenses due to loss, damage, detention or delay in the delivery of equipment or parts resulting from acts beyond the control of Bush Hog.

### THIS LIMITED WARRANTY SHALL NOT APPLY:

1. To vendor items which carry their own warranties, such as engines, tires, and tubes.
2. If the unit has been subjected to misapplication, abuse, misuse, negligence, fire or other accident.
3. If parts not made or supplied by Bush Hog have been used in connection with the unit, if, in the sole judgment of Bush Hog such use affects its performance, stability or reliability.
4. If the unit has been altered or repaired outside of an authorized Bush Hog dealership in a manner which, in the sole judgment of Bush Hog, affects its performance, stability or reliability.
5. To normal maintenance service and normal replacement items such as gearbox lubricant, hydraulic fluid, worn blades, or to normal deterioration of such things as belts and exterior finish due to use or exposure.
6. To expendable or wear items such as teeth, chains, sprockets, belts, springs and any other items that in the company's sole judgment is a wear item.

NO EMPLOYEE OR REPRESENTATIVE OF BUSH HOG IS AUTHORIZED TO CHANGE THIS LIMITED WARRANTY IN ANY WAY OR GRANT ANY OTHER WARRANTY UNLESS SUCH CHANGE IS MADE IN WRITING AND SIGNED BY BUSH HOG'S SERVICE MANAGER, 2501 GRIFFIN AVE., SELMA, ALABAMA 36703.



Record the model number, serial number and date purchased. This information will be helpful to your dealer if parts or service are required.

MODEL NUMBER \_\_\_\_\_

SERIAL NUMBER \_\_\_\_\_

MAKE CERTAIN THE WARRANTY HAS BEEN FILED WITH BUSH HOG SELMA, ALABAMA

DATE OF RETAIL SALE \_\_\_\_\_



**BUSH HOG®**



# ASSEMBLY SECTION

Assembly Section 3-1

# ASSEMBLY

ASSEMBLY

## DELIVERY AND ASSEMBLY

### Checking the Machine on Delivery

All parts are carefully checked before dispatch or delivery.

On receiving the machine, ensure that it has not been damaged during transport. If damage has occurred, contact the dealer concerned.

Details of packing are given below.



Use caution and wear protective gloves when handling sharp objects such as blades, knives, and other cutting edges. Be alert to worn component surfaces which have sharp edges. Sharp surfaces can inflict severe laceration injuries if proper hand protection is not worn. (SG-37) str



Make sure the area around the machine is clear before lowering the wings. Do not lower the tedder wings when people or pets are near the rotary tedder or folding mechanism. The tedder must be attached to the tractor when the wings are folded.



Never work under the Implement, the framework, or any lifted component unless the Implement is securely supported or blocked up to prevent sudden or inadvertent falling which could cause death or serious injury. (SG-14)str



### Unpacking the Machine

- Lift the machine using a forklift truck, crane or other suitable equipment of sufficient capacity after first checking the weight of the configurations in the table given below.
- Check the stability and positioning of the load on the forklift truck forks or crane hook.
- Keep the load as low as possible during movement for maximum stability and to ensure that the operator has maximum visibility.
- If a forklift truck is used, ensure that the forks are positioned as wide apart as possible.

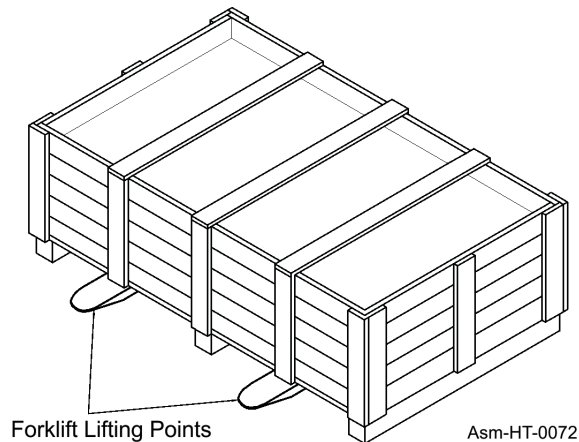

MACHINE	PACKING WEIGHT	MACHINE WEIGHT
HT417	1157 lbs/525 kg	1014 lbs/460 kg
HT417H	1190 lbs/540 kg	1047 lbs/475 kg

# ASSEMBLY

## NOTE:

1. The packing consists mainly of wood, which should be disposed of according to the laws in force in the country where the machine is used. The plastic film should also be disposed of according to the laws in force in the country where the machine is used.
2. When storing, it is permissible to stack 2-3 crates on top of each other. Make sure that they are perfectly aligned.
3. In the event of further transport, ensure that the machine went on the transporting vehicle.

## **GENERAL ASSEMBLY**

Assembly is highly dangerous and must be carried out in strict accordance with the following instructions. We recommend that qualified personnel perform assembly. It is highly recommended that assembly be carried out in a flat, solid surface, open area with no people (particularly children) nearby who could be severely be injured if they were to touch or move any parts of the machine.

When assembling the implement provide suitable lifting mechanisms and supports to stabilize the partially assembled implements. This will prevent them from falling and causing damage to the implement or serious injury. The steps for assembly are illustrated in the following pages. Depending on the experience of the assemblers and the tools available, it is not necessary that the instructions be followed in the exact order given here, but the safety precautions described above must always be followed carefully and scrupulously.



Make sure the area around the machine is clear before lowering the wings. Do not lower the tedder wings when people or pets are near the rotary tedder or folding mechanism. The tedder must be attached to the tractor when the wings are folded.



Always use safety stands or blocking in conjunction with hydraulic jacks or joists. Do not rely on the jack or joist to carry the load. They could fail.

## **SUPPORT AND WHEEL ASSEMBLY**

1. To facilitate the assembly of the wheel supports, it is advised that the machine body be turned upside down. If you use a different assembly method, keep in mind that once pins (5) and bushings (6) (pre-assembled by in the shop to guarantee correct assembly and safe handling of the machine) are removed, the rotor assemblies 1,2,3,4 are free to move from their mountings, causing problems for correct assembly and for the safety of the operators. **USE MAXIMUM CAUTION**
2. (Refer to Section A of **Asm-HT-0010**) Remove pins (5) and bushings (6) (keep in mind warnings in step 1).
3. To avoid errors in assembly, we have numbered both the wheel supports 1,2,3,4 and the rotor assemblies 1,2,3,4 with decals. Combine the wheel support marked with 1 and so on.
4. Before moving on to the fastening of wheel supports 1,2,3,4 to the respective rotors, make sure that the position of the holes A,B,C,D of the rotor disc are positioned as shown.
5. (Refer to section B of **Asm-HT-0010**) Now fasten wheel supports 1,2,3,4 using pins 5 and 7.
6. (Refer to section C of **Asm-HT-0010**) Attach the large hay guards 7 to wheel supports 1,2,3,4 followed by wheels 8, small hay guards 9, washers 10 and fasten with nuts 11.
7. Item 5, 4 Spring pins  $\varnothing 10 \times 55$  (0.39" x 2.17")
8. Item 7, 4 Spring pins  $\varnothing 6 \times 55$  (0.24 x 2.17")
9. Item 10, 4 Flatwashers  $\varnothing 17$  (0.67")
10. Item 11, 4 nuts M16Connect the fittings

# ASSEMBLY

**NOTE:** At this point the tine arms could be attached because the machine is in a favorable position, but once the arms are attached it is more difficult to turn the machine over. If the assembler wishes to attach them at this stage, See Step "E".

ASSEMBLY

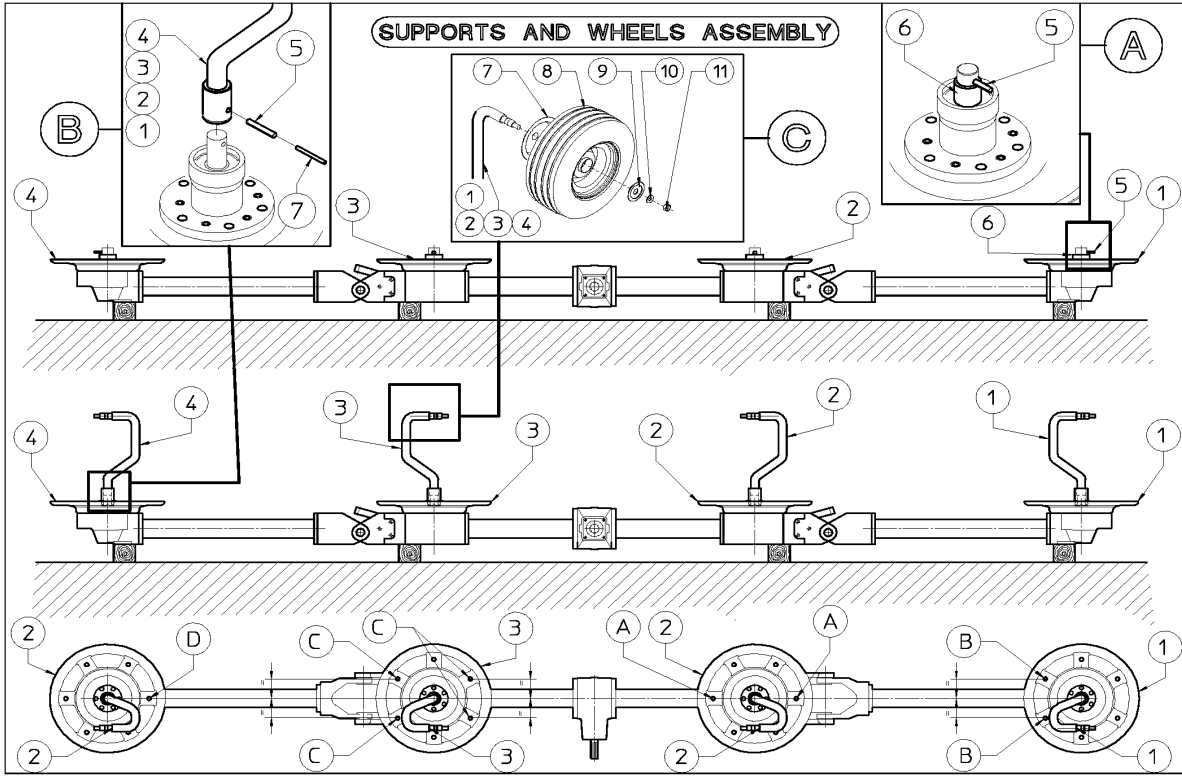

Asm-HT-0010



# ASSEMBLY

ASSEMBLY

## ASSEMBLY STEPS

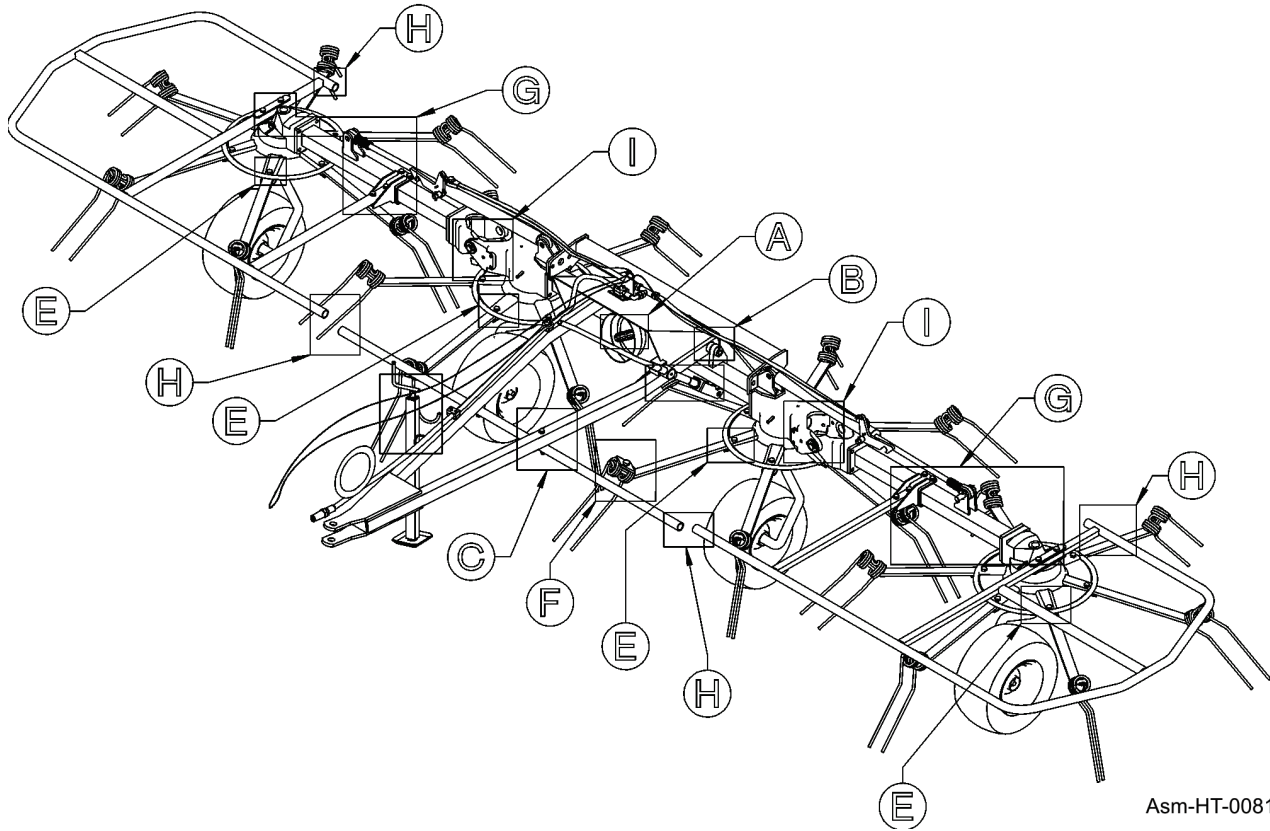

### STEP "A"

Attach guard 1 to the central gearbox 2 using nuts 3.

In this step, you will use:

Item 3, 2 nuts M8.

Asm-HT-0039

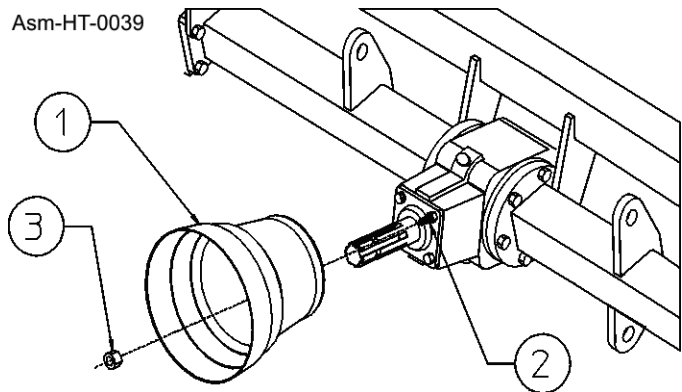

# ASSEMBLY

## ASSEMBLY

### STEP "B"

Attach drawbar 1 to the machine body 2 with pin 3 into the holes 5 of the machine body 2 and drawbar 1 (passing pin 3 through hole 4 of the machine body 2). Fasten pin 3 with bushing 6 and split pins 7.

In this step, you will use:

Item 6, 2 bushing  $\varnothing 20,5/30 \times 12$  ( $\varnothing 0.8"/1.2" \times 0.47"$ )

Item 7, 2 split pins  $\varnothing 5 \times 40$  ( $\varnothing 0.2" \times 1.57"$ )

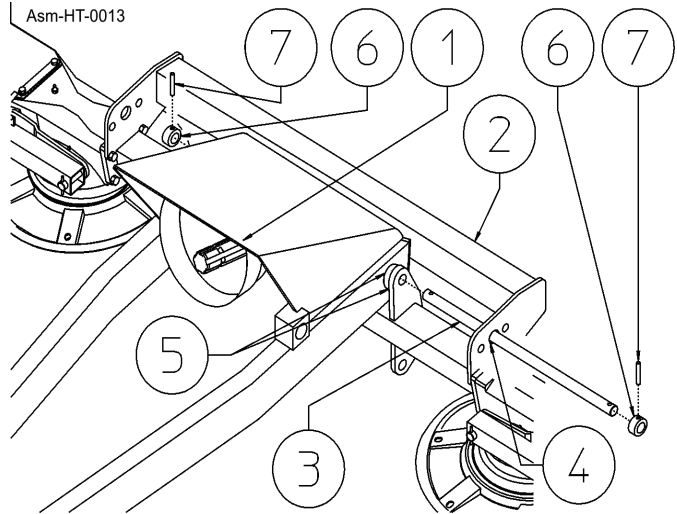

### STEP "C"

Attach grease fitting 1 to the pin and fork of the crank assembly 2. Insert the pin of the crank assembly 2 into its seat in drawbar 3, inserting the spacers 4. Fasten in place with split pin 5. Fasten the fork of the crank assembly 2 at the hole 6 using pin 7 and split pins 5.

In this step you will use:

Item 1, 3 grease nipples M6

Item 4, 2 shims  $\varnothing 30.5 \times 39.8 \times 1$  ( $\varnothing 1.2" \times 1.57" \times 0.04"$ )

Item 5, 3 split pins  $\varnothing 5 \times 40$  ( $\varnothing 0.2" \times 1.57"$ )

Item 7, 1 pin  $\varnothing 20 \times 66$  ( $\varnothing 0.79" \times 2.6"$ )

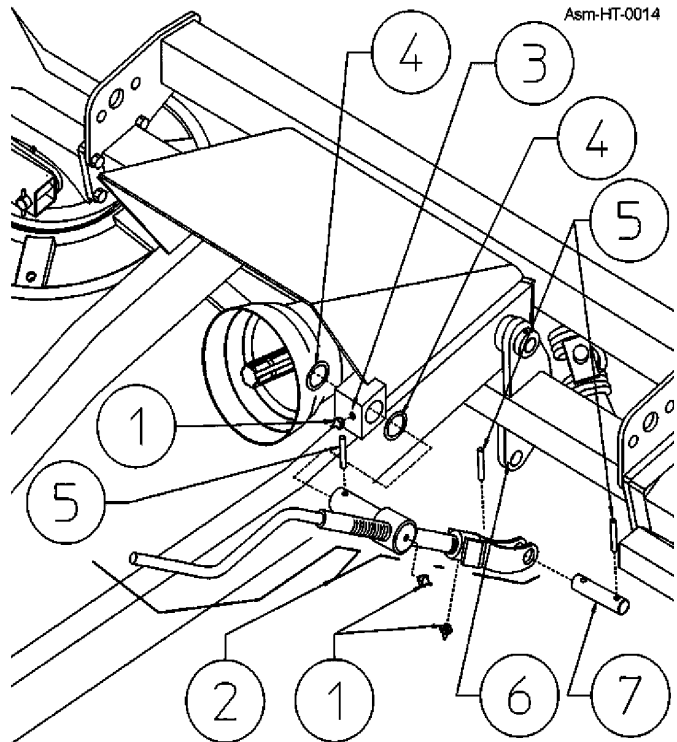

# ASSEMBLY

## STEP "D"

Attach the parking stand 1 to drawbar 2 fastening it with pin 3 and clip 4.

In this step, you will use:

Item 3, 1 pin  $\varnothing 15$  ( $\varnothing 0.59$ " )

Item 4, 1 clip  $\varnothing 3$  ( $\varnothing 0.12$ " )

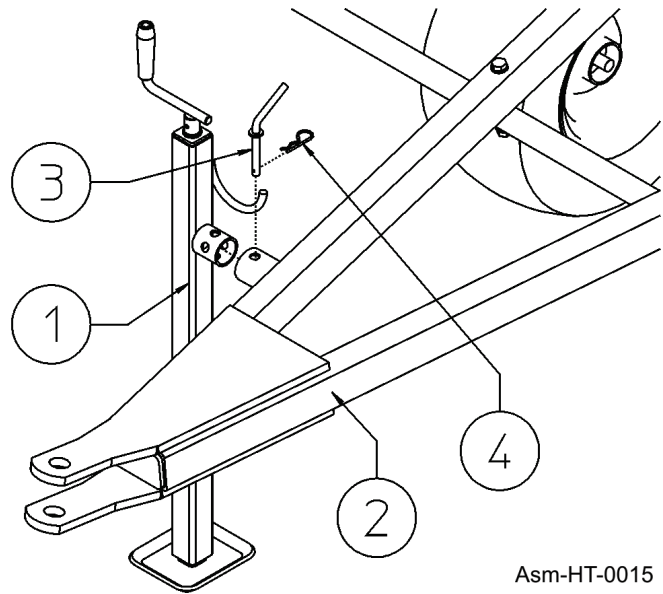

Asm-HT-0015

## STEP "E"

You will find tine bars 1(RH) and 2(LH) in four bundles (two RH and two LH) of six pieces each

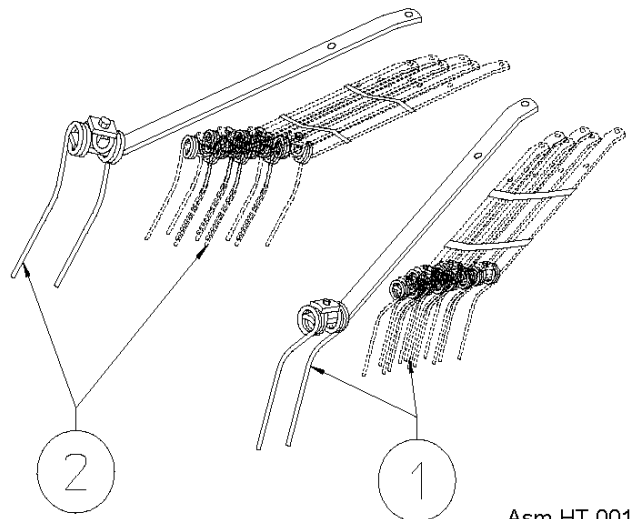

Asm-HT-0016

# ASSEMBLY

ASSEMBLY

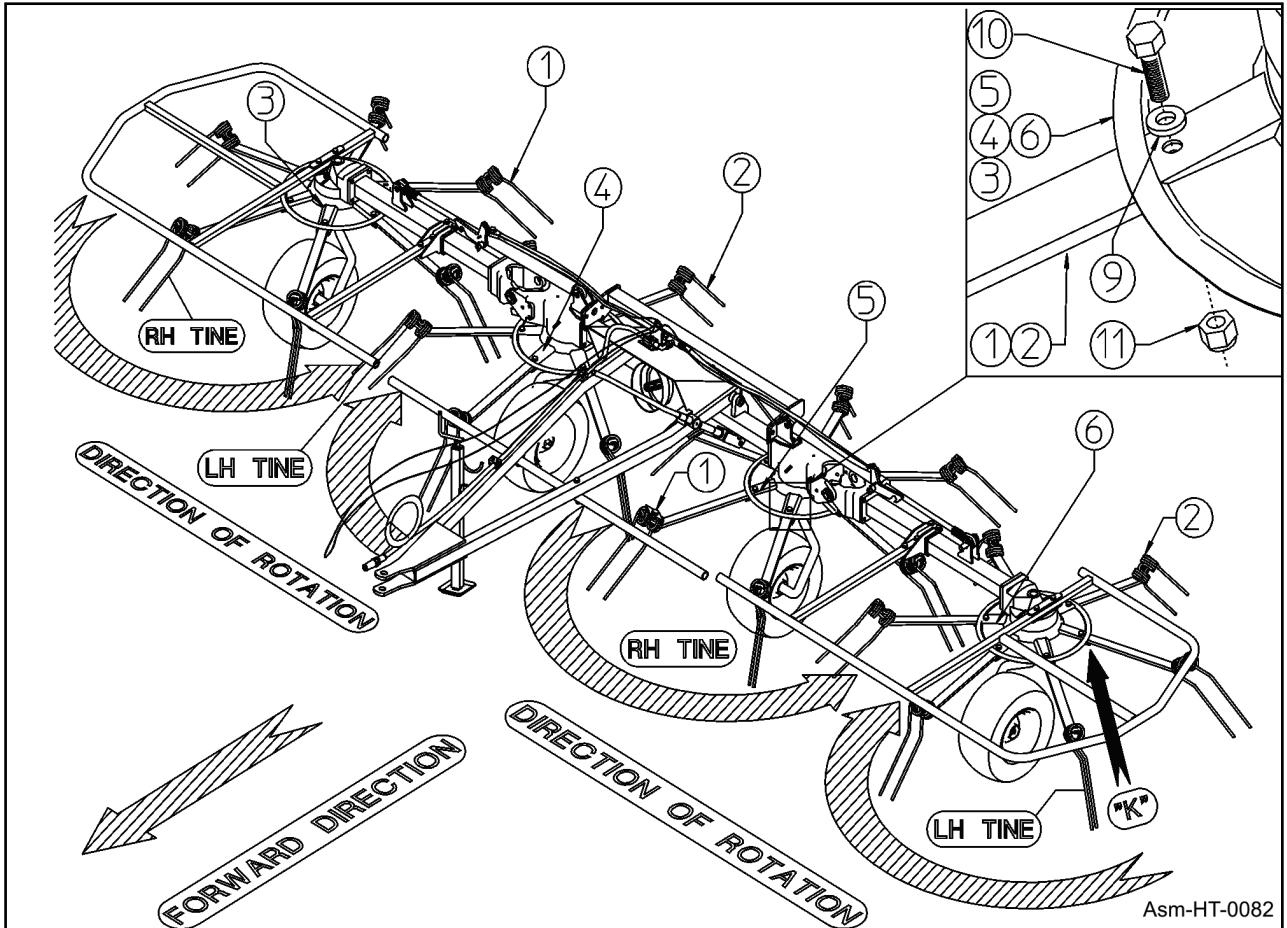

Asm-HT-0082

## STEP "F"

Tine bars 1(RH) are attached to rotors 3-5. Tine bars 2(LH) are attached to rotors 4-6.

Attach tine bars 1(RH) and 2(LH) to respective rotors 3-5 (RH) and 4-6(LH) with screws 7, spring washers 8, washers 9, screws 10 and nuts 11.

In this step, you will use:

Item 7, 24 screws M12x30 (0.47"x1.18")

Item 8, 24 spring washers  $\phi 13$  ( $\phi 0.51$ ")

Item 9, 24 washers  $\phi 13$  ( $\phi 0.51$ ")

Item 9. (View "K") 24 Washers  $\phi 12.5-28.5 \times 3$  ( $\phi 0.5$ ")

Item 10, 24 screws M12x40 (0.47"x1.38")

Item 11, 24 nuts M12

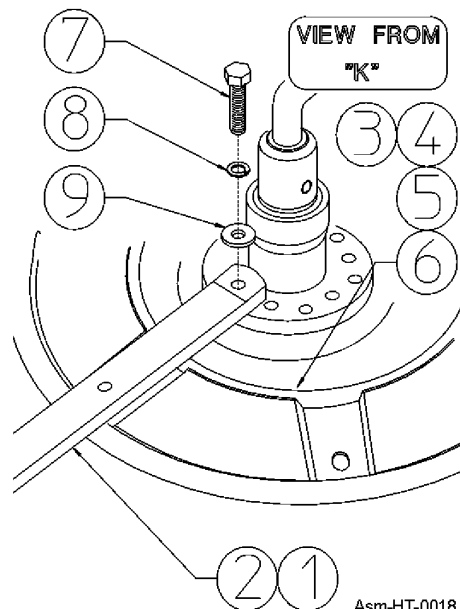

Asm-HT-0018

# ASSEMBLY

## STEP "G"

Attach the central guard 1 to drawbar 2 using screws 3, washers 4, plate 5 and nut 6.

In this step, you will use:

Item 3, 2 screws M10x120 (0.39"x4.72")

Item 4, 2 washers  $\varnothing 10.5$  ( $\varnothing 0.41$ " )

Item 5, 2 plate

Item 6, 2 nuts M10

Asm-HT-0019

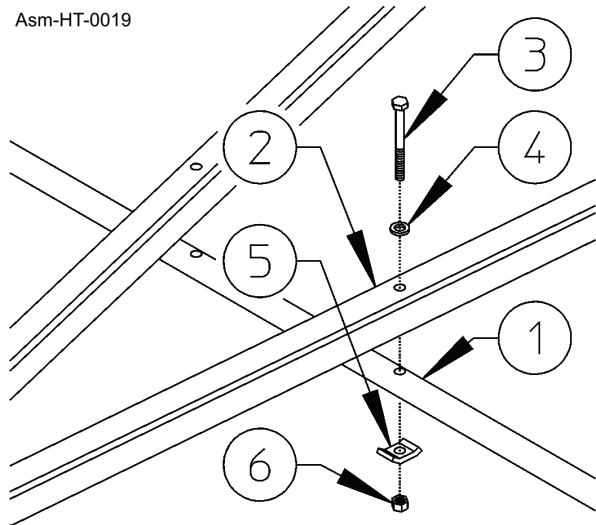

## STEP "H"

Secure the caps support 1 to the body with screws 2, washers 3, and nuts 4.

Attach to a distance of 11.22"-285mm.

Attach the protections 5 (DX-SX) to support 1 with the screws 8, washers 9, and nuts 10.

Attach the protection 5 (DX-SX) to the box with screws 6, and washers 7.

In this step, you will use:

Item 2, 4 screws M12x110 (0.47"x4.33")

Item 3, 8 washers  $\varnothing 13$  ( $\varnothing 0.51$ " )

Item 4, 4 nuts M12 (0.47")

Item 6, 4 screws M12x60 (0.47"x2.36")

Item 7, 4 spring washer  $\varnothing 13$  ( $\varnothing 0.51$ " )

Item 8, 4 screws M10x55 (0.39"x2.16")

Item 9, washers  $\varnothing 10$  ( $\varnothing 0.39$ " )

Item 10, 4 nuts M10 ( $\varnothing 0.39$ " )

Item 11, 2 grease nipples M10

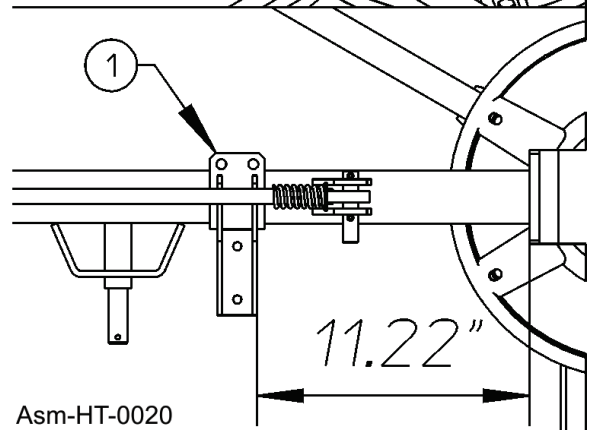
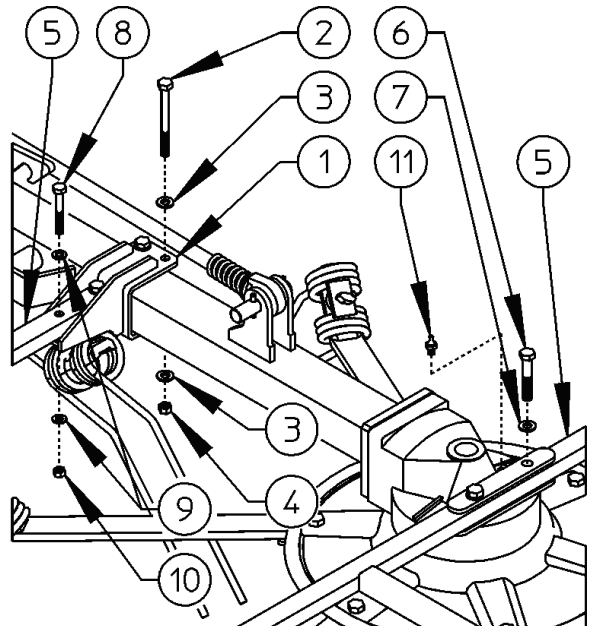

Asm-HT-0020

# ASSEMBLY

## STEP "I"

Apply caps 3 to lateral guard 1 (RH-LH) and to center guard 2.

In this step, you will use:

Item 3, 6 caps  $\varnothing 32$  ( $\varnothing 1.25$ " )

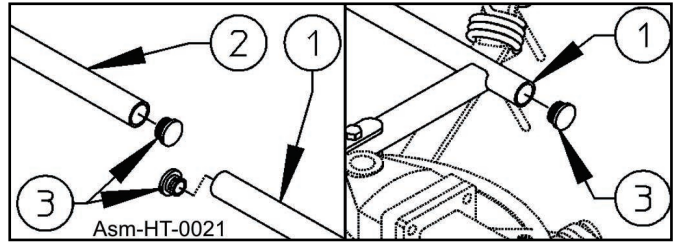

## STEP "J"

Attach the guards 3 (RH and LH side) and plates 4-5 using washers 6 and screws 7. Attach grease nipple 1-2 in the proper holes (RH and LH Side).

In this step, you will use:

Item 1, 2 grease nipples M10

Item 2, 4 grease nipple M6

Item 6, 8 flat washers  $\varnothing 8.5$  ( $\varnothing 0.33$ " )

Item 7, 8 screws M8x16 (0.31"x0.63" )

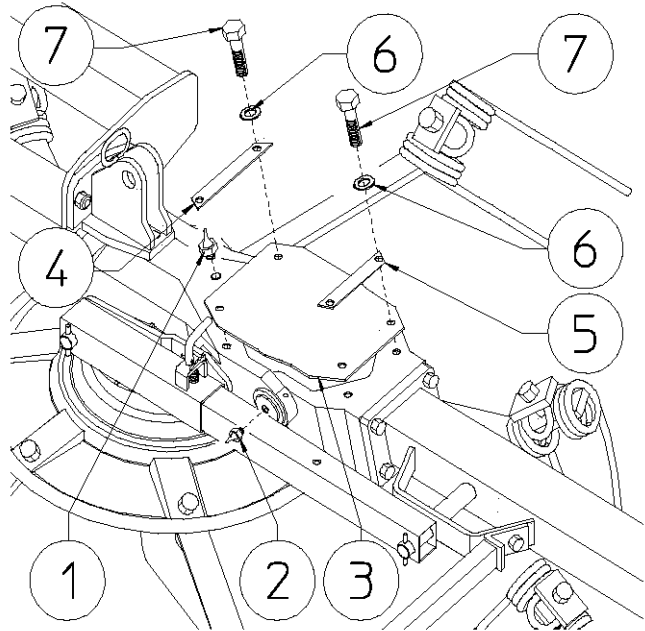

# ASSEMBLY

ASSEMBLY

## ASSEMBLY STEPS FOR HYDRAULIC KIT

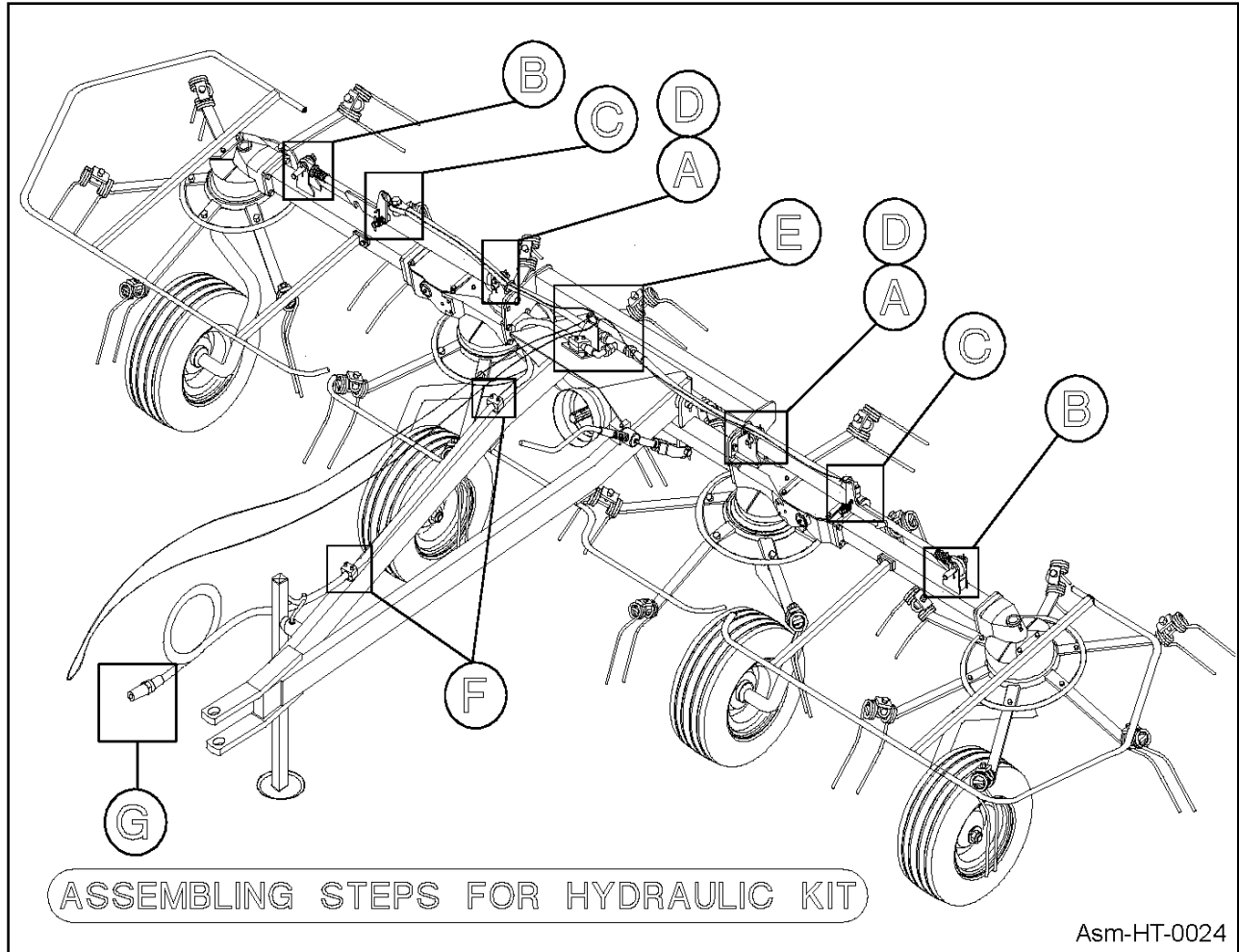

# ASSEMBLY

## ASSEMBLY

### STEP "A"

Attach the supports 1\* (RH and LH side) using washers 3\*-6\*, screws 2\*-5\* and nuts 4\*. Attach the cylinders 7-8 (RH-LH) using pins 9 and spring pins 10.

In this step, you will use:

Item 2\*, 4 screws M12x35 (0.47"x1.38")

Item 3\*, 6 flat washers  $\varnothing$ 13 (0.51")

Item 4\*, 4 nuts M12 (0.51")

Item 5\*, 2 screws M12x25 (0.47"x1")

Item 6\*, 2 spring washers  $\varnothing$ 13 (0.51")

Item 9, 2 pins  $\varnothing$ 20x70 (0.79"x2.76")

Item 10, 4 spring pins  $\varnothing$ 6x35 (0.24"x1.38")

\* They are valid if we convert a machine with manual fold into one with hydraulic fold.

These particulars are included on those machines already planned with hydraulic fold.

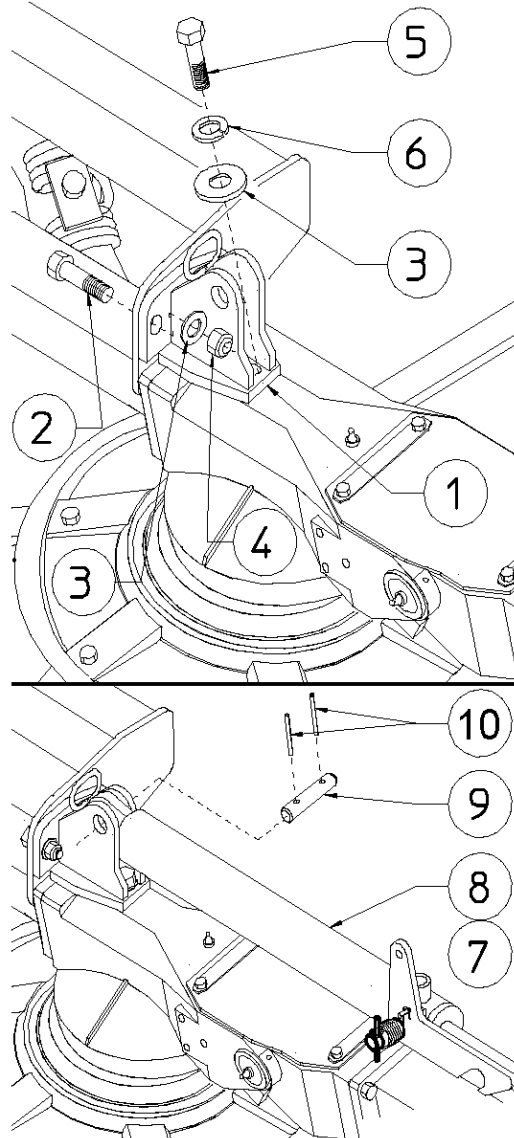

Asm-HT-0025

Asm-HT-0026

### STEP "B"

Continue to secure cylinders 7-8 (RH-LH) using pins 1 and springs pins 2.

In this step you will use:

Item 1, 2 pins  $\varnothing$ 20x95 (0.79"x3.74")

Item 2, 4 spring pins  $\varnothing$ 6x35 (0.24"x1.38")

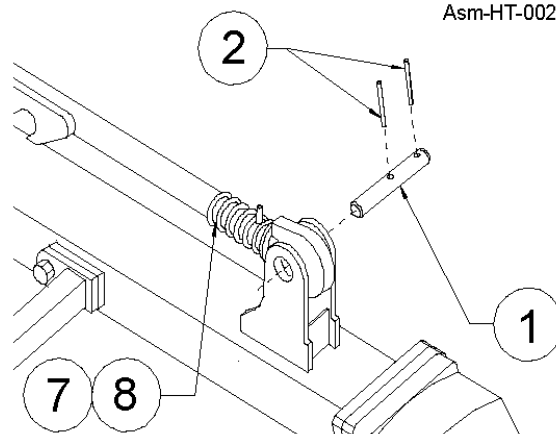

HT417/HT417H 08/22

Assembly Section 3-12



# ASSEMBLY

## STEP "C-D"

Pass hoses 2 and rope 6 through loops 7 on cylinders support (RH and LH side). Attach the eye hose 2 to hole 1 (RH and LH side) using washers 3 and fitting 4. Fasten rope 6 to lever 5. (RH and LH side)

In this steps you will use:

Item 2, 2 hoses 1/4"x1020 (1/4"x40")

Item 3, 4 copper washers 3/8"

Item 4, 2 fittings 3/8"

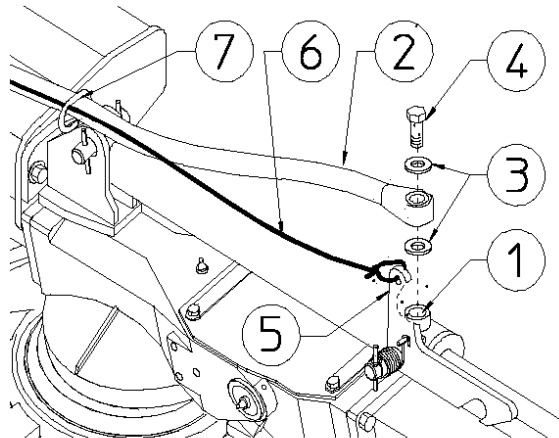

Asm-HT-0027

## STEP "E"

Attach the support 1 to drawbar 3 using screws 4 and nuts 5. Join hoses 2 to connector 6. Attach nipple 7 to connector 6. Attach hose 8 to nipple 7. Secure hose 8 with collars 9 and screws 10. Pass rope 11 through loop 12 on support 1.

In this step, you will use:

Item 2, 2 hoses (step C-D)

Item 4, 2 screws M6x16 (0.24"x0.63")

Item 5, 2 nuts M6 (0.24")

Item 6, 1 "T" connector 1/4"

Item 7, 1 nipple 1/4" -3/8"

Item 8, 1 hose 3/8"x2900 (3/8"x114")

Item 9, 2 hose collars  $\varnothing 18$  ( $\varnothing 45/64$ ")

Item 10, 2 screws M6x25 (0.24"x1")

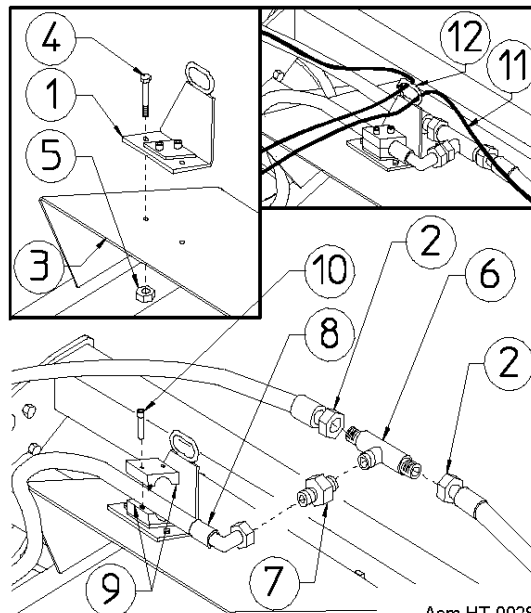

Asm-HT-0028

## STEP "F-G"

Continue to secure hose 8 using collars 1 and screws 2. Attach the rapid coupling 4 and washer 3 to hose 8.

In this step, you will use:

Item 1, 4 hose collars  $\varnothing 18$  ( $\varnothing 45/64$ ")

Item 2, 4 screws M6x25 (0.24"x1")

Item 3, 1 copper washer 1/2"

Item 4, 1 rapid coupling 1/2"

Item 8, hose (Step E)

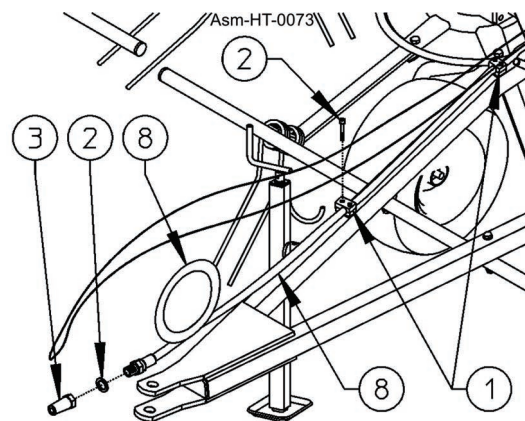

Asm-HT-0073

# ASSEMBLY

Assembly is now completed, and the machine should appear as shown in the illustration.

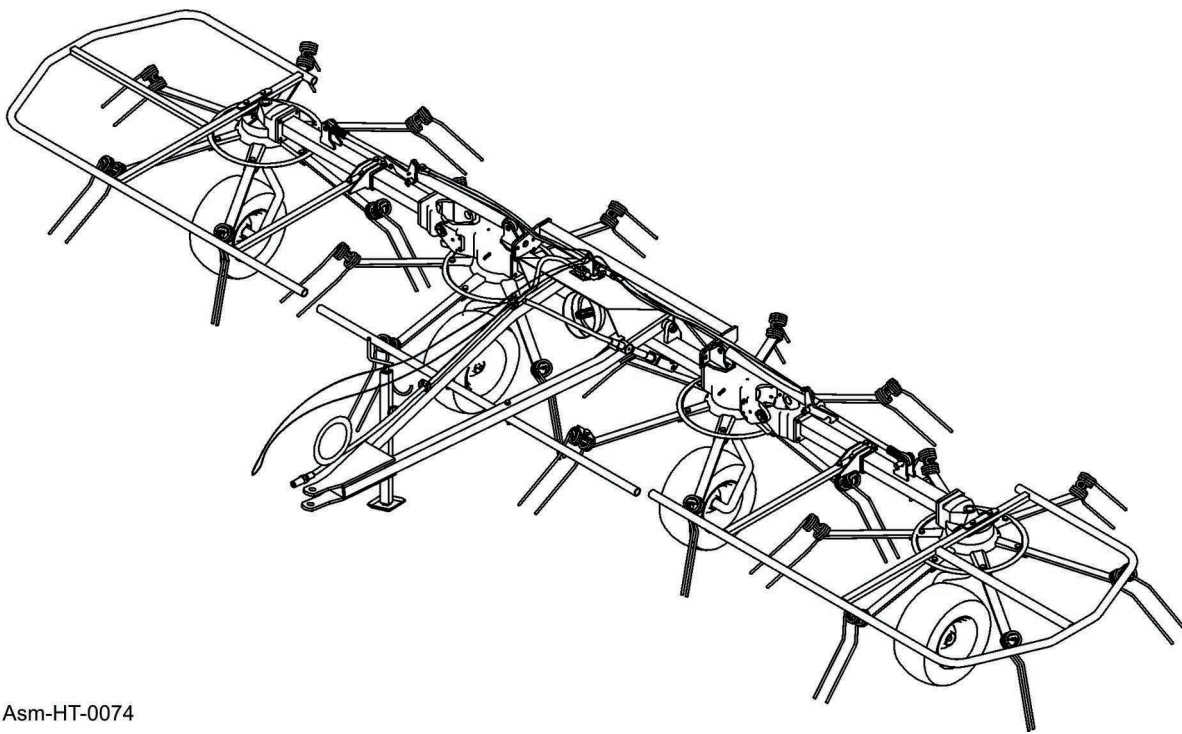

Asm-HT-0074

## HYDRAULIC TILT KIT ASSEMBLY

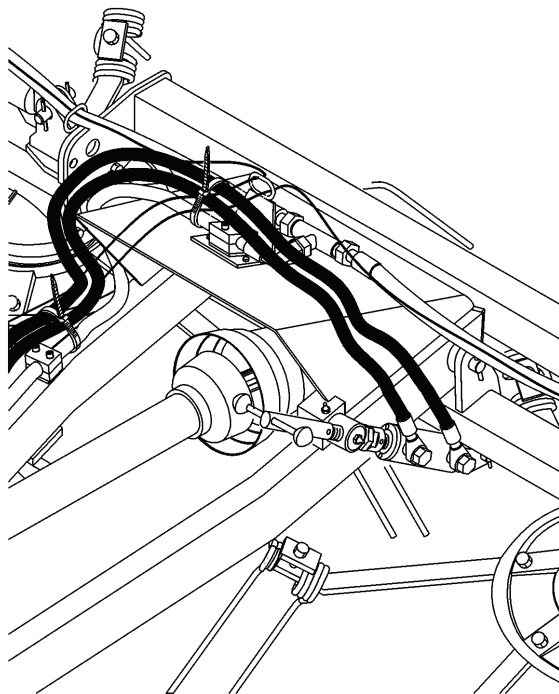

HT417/HT417H 08/22

Assembly Section 3-14

# ASSEMBLY

## STEP 1

To Assemble the Hydraulic Tilt Kit to the Tedder the manual adjustment link Item 1 must be removed.

**NOTE:** Keep in mind the **DANGER** resulting from the removal of Link 1, because once the machine no longer has the connection between the drawbar and the frame, the frame tends to open out. This will constitute a serious danger.

Stabilize the machine to prevent the machine from opening out when the connection is broken.

At this point to remove the adjustment Link 1, it is necessary to remove the pins 2 and 3 on the fork side and pin 4 and washer 5 on the adjustment screw.

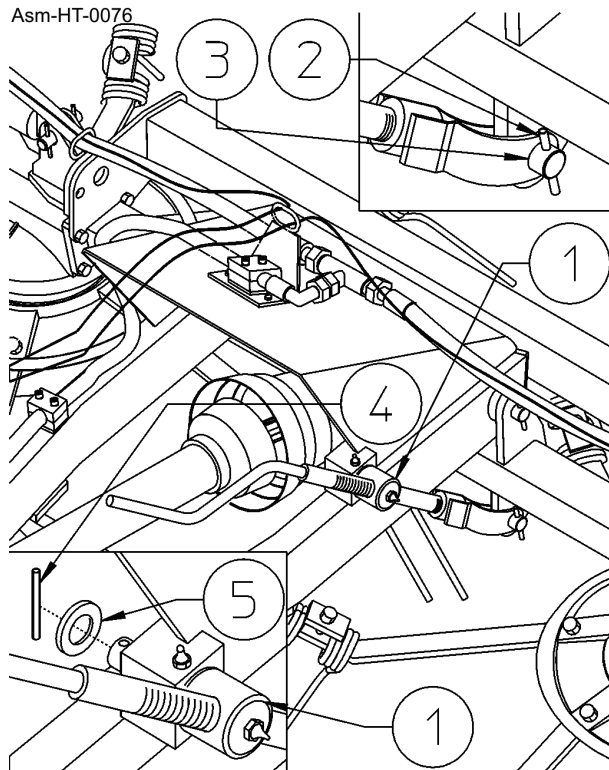

## STEP 2

Fasten the adjustment screw part of the cylinder 1 onto the drawbar using shims 2 and nuts 3.

Fasten the fork part of the cylinder to the frame using shim 4, pin 5, and spring pin 6.

**NOTE:** Shim 4 goes on the side shown in the drawing

In this step, you will use:

Item 2, 2 Shims M30.5-40x1 (1.2"-1.57"x0.39")

Item 3, 2 Nuts M30

Item 4, 1 Shim M20.5 - 40x6 (.81"-1.57"x.24")

Item 5, 1 Pin M20x70 (.79"x2.76")

Item 6, 2 Spring Pin M6x35 (.24x1.38")

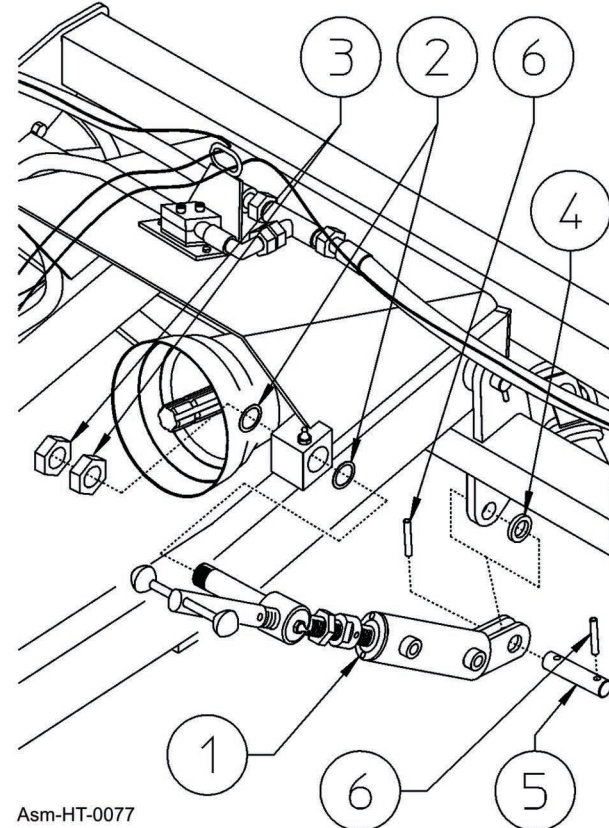

# ASSEMBLY

## ASSEMBLY

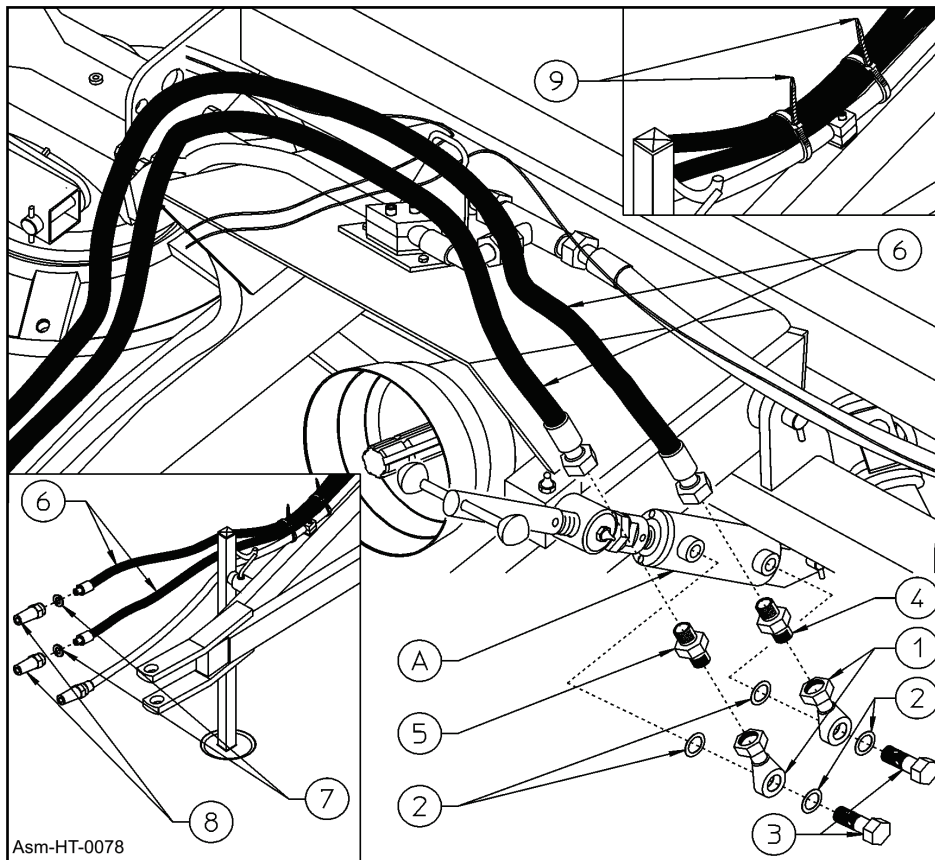

### **STEP 3**

1. Connect the fittings 1 to the cylinder A using washers 2 and screws 3.
2. Connect the reducer flow 4 to the fitting 1.
3. Connect the nipple 5 to the fitting 1.
4. Connect the hoses 6 to the reducer flow 4 and nipple 5.
5. Extend hoses 6 along the drawbar until it reaches the front part.
6. Lock the hoses 6 with clips 9. Apply the washers 7 and rapid couplings 8 to the hoses 6.

In this step, you will use:

Item 1, 2 Fitting 3/8"

Item 2, 4 Washers 3/8"

Item 3, 2 Screws 3/8"

Item 4, 1 Flow Reducer 3/8"x.8mm

Item 5, 1 Nipple 3/8"x3/8"

Item 6, 2 Hose 3/8"x1.35-138"

Item 7, 2 Washers 1/2"

Item 8, 2 Quick Couplers 1/2"

Item 9, 8 Zip Ties #10

HT417/HT417H 08/22

Assembly Section 3-16

# ASSEMBLY

## **HAY TEDDER ADJUSTMENTS**

Connect the hoses "A" to the tractor hydraulic couplings. Now send the hydraulic oil to the leveling cylinder and adjust the machine according to your needs.

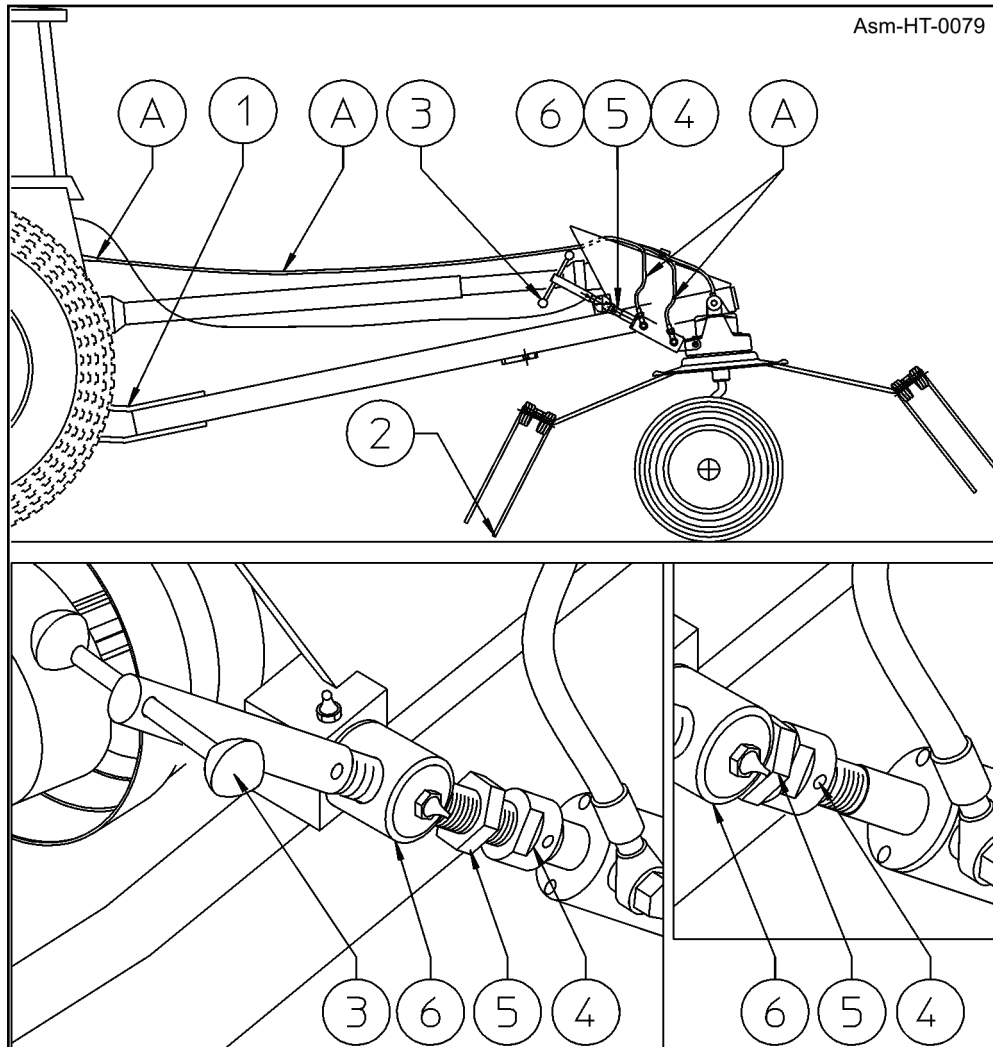

ASSEMBLY

The attaching of the drawbar 1 to the tractor hitch already brings the machine into an initial position, and normally this makes it possible to make the adjustments required for the working and transport stages. Sometimes tractors that have a hitch that is too high or too low may cause the machine adjustment to be unsatisfactory. If this is the case, take appropriate countermeasures. If the drawbar 1 is hooked to the bar of the tractor lift, the height can be adjusted at any time and therefore adjustments to the machine are easier. Normally you have good working conditions when the tines 2 at the front of the machine brush against the ground. If after the machine has been put in the working position the tines 2 are too far from the ground or dig too deep into the ground, away from the joint pin 6 so as to allow the movement of the adjustment screw connected to the lever 3. Now move lever 3 to bring tine 2 so that it brushes against the ground. At this point bring nut 5 back into contact with joint pin 6 and bushing 4 into contact with nut 5. Before tightening them to each other, make the adjustments in the next step.



# ASSEMBLY

## ASSEMBLY

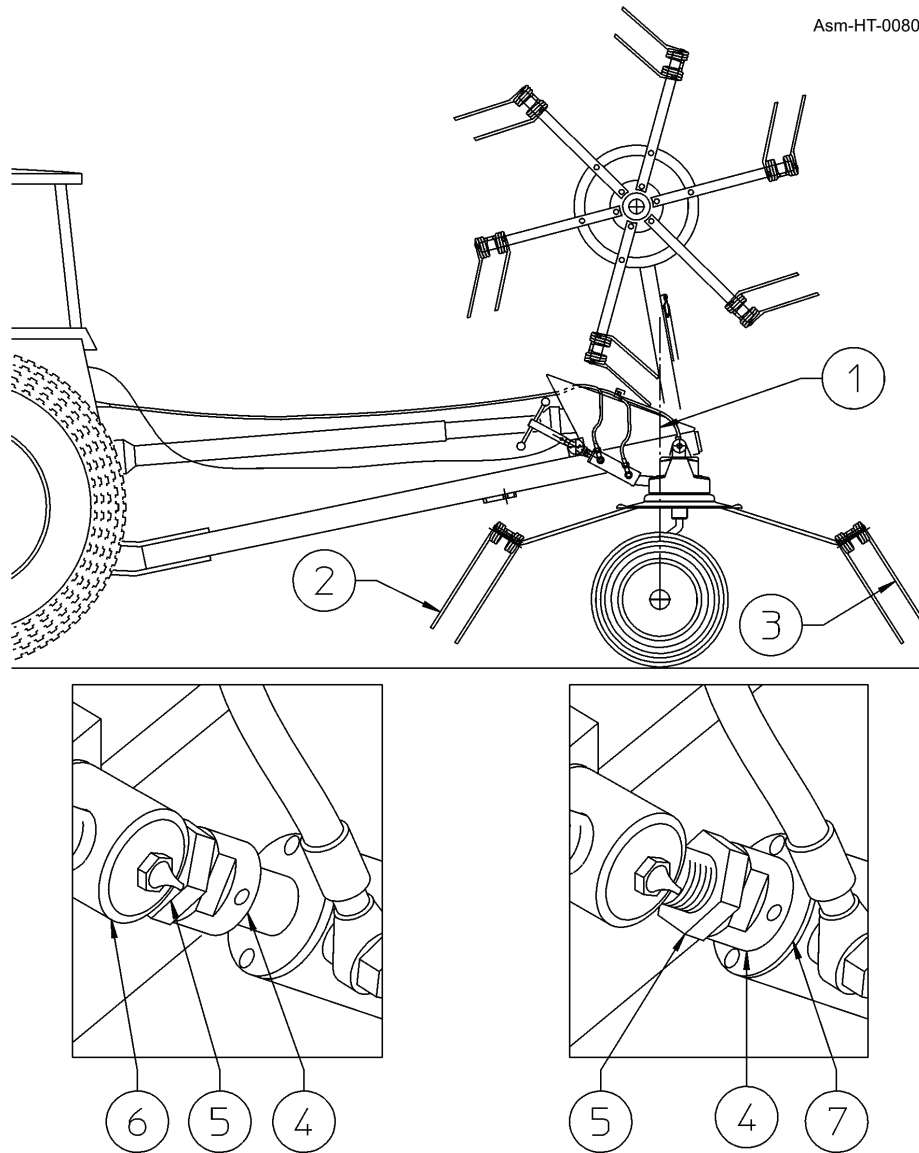

Now, sending oil from the tractor hydraulic circuit, raise the side rotors 1. The correct transport position (or maneuvering position when in the field) is when tine 2 at the front of the machine and tine 3 at the back are approximately the same distance from the ground.

**NOTE:** For reasons of stability, the weight of the machine with regard to wheel axle A must always be unbalanced with more weight at the front, to avoid having the machine tip backwards when it is detached from the tractor due to it being heavier at the back. Therefore it must be unbalanced toward the front even if tine 2 is slightly closer to the ground than tine 3.

When the correct transport position is reached, bring bushing 4 into contact with the front face of cylinder 7, bring nut 5 into contact with bushing 4 and tighten them together. With this adjustment the machine is ready for working and transport.

# OPERATION SECTION

Operation Section 4-1

# OPERATION

## BUSH HOG HT417/HT417H HAY TEDDER OPERATING INSTRUCTIONS

Your Bush Hog Hay Tedder should now be assembled and inspected for any evidence of defective or damaged parts before use. Any evidence of damage should be reported to your dealer immediately. After Hydraulic Lines have been attached to tractor and drawbar hitch is attached, carefully raise parking jack

This section of the Operator's Manual is designed to familiarize, instruct, and educate safe and proper implement use to the operator. Pictures contained in this section are intended to be used as a visual aid to assist in explaining the operation of a Hay Tedder and are not necessarily of a HT417. Some pictures may show shields removed for purposes of clarity. NEVER OPERATE this implement without all shields in place and in good operational condition. The operator must be familiar with the implement and tractor operation and all associated safety practices before operating the implement and tractor. Proper operation of the implement, as detailed in this manual, will help ensure years of safe and satisfactory use of the hay tedder.

**READ AND UNDERSTAND THE ENTIRE OPERATING INSTRUCTIONS AND SAFETY SECTION OF THIS MANUAL AND THE TRACTOR MANUAL BEFORE ATTEMPTING TO USE THE TRACTOR AND IMPLEMENT.** If you do not understand any of the instructions, contact your nearest authorized dealer for a full explanation. Pay close attention to all safety signs and safety messages contained in this manual and those affixed to the implement and tractor. *OPS-U- 0001str*

READ, UNDERSTAND, and FOLLOW the following Safety Messages. Death or serious injury may occur unless care is taken to follow the warnings and instructions stated in the Safety Messages. Always use good common sense to avoid hazards. (SG-2str)





# OPERATION

## 1. STANDARD EQUIPMENT AND SPECIFICATIONS

	HT417	HT417H
Number of Rotors	4	4
Number of Arms	24	24
Horsepower Requirements	22 HP minimum	22 HP minimum
Working Width	17 Ft	17 Ft
Transport Width (Approximate)	10 Ft	10 Ft
Weight Approximate	1014 lbs	1047 lbs
Tire Size	16.00 x 6.5 -6 ply	16.00 x 6.5 -6 ply
Number of Tires	4	4
PTO	540 RPM, 1-3/8" Spline with slip clutch	540 RPM, 1-3/8" Spline with slip clutch
Folding Mechanism	Spring Assist	Hydraulic
Working Speed	5 - 10 MPH	5 - 10 MPH

# OPERATION

## 2. OPERATOR REQUIREMENTS

Safe operation of the unit is the responsibility of a qualified operator. A qualified operator has read and understands the implement and tractor Operator's Manuals and is experienced in implement and tractor operation and all associated safety practices. In addition to the safety messages contained in this manual, safety signs are affixed to the implement and tractor. If any part of the operation and safe use of this equipment is not completely understood, consult an authorized dealer for a complete explanation.

If the operator cannot read the manuals for themselves or does not completely understand the operation of the equipment, it is the responsibility of the supervisor to read and explain the manuals, safety practices, and operating instructions to the operator.

Safe operation of equipment requires that the operator wear approved Personal Protective Equipment (PPE) for the job conditions when attaching, operating, servicing, and repairing the equipment. PPE is designed to provide operator protection and includes the following safety wear:

### PERSONAL PROTECTIVE EQUIPMENT (PPE)

- Always Wear Safety Glasses (with side shields marked to comply with ANSI Z87)
- Hard Hat
- Steel Toe Safety Footwear
- Gloves
- Hearing Protection
- Close Fitting Clothing
- Respirator or Filter Mask (depends on operating conditions)

OPS-U- 0002str

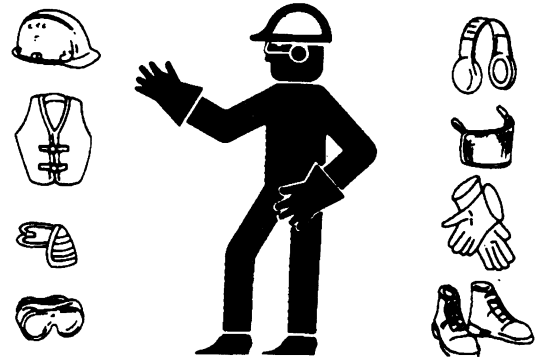

### **⚠ DANGER**

DO NOT use drugs or alcohol immediately before or while operating the Tractor and Implement. Drugs and alcohol will affect an operator's alertness and coordination and therefore affect the operator's ability to operate the equipment safely. Before operating the Tractor or Implement, an operator on prescription or over-the-counter medication must consult a medical professional regarding any side effects of the medication that would hinder their ability to operate the Equipment safely. NEVER knowingly allow anyone to operate this equipment when their alertness or coordination is impaired. Serious injury or death to the operator or others could result if the operator is under the influence of drugs or alcohol.

(SG-27) str

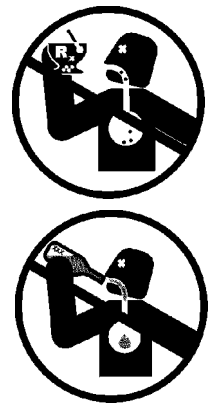

# OPERATION

## 3. TRACTOR REQUIREMENTS

The tractor used to operate the tedder must have the power capacity to lift, pull, and operate the Power Take Off (PTO) at the tedder's rated speed while traveling at a ground speed between 2 and 5 PMPH. Operating the tedder with a tractor that does not meet the following requirements may cause tractor or tedder damage and be a potential danger to the operator and passerby.

### Tractor Requirements and Capabilities

- ASABE approved Roll-Over Protective Structure (ROPS) or ROPS cab and seat belt.
- Tractor Safety Devices ..... Slow Moving Vehicle (SMV) emblem, lighting, PTO master shield
- Tractor Horsepower.....22 HP minimum
- Front End Weights.....As needed to maintain 20% weight on front axle

### 3.1 ROPS and Seat Belt

The tractor must be equipped with a Roll-Over-Protective-Structure (ROPS), tractor cab, or roll-bar and seat belt to protect the operator from falling off the tractor, especially during a roll over where the driver could be crushed and killed. Only operate the tractor with the ROPS in the raised position and seat belt fastened. Tractor models not equipped with a ROPS and seat belt should have these life saving features installed by an authorized dealer. OPS-U- 0003str



Operate this Equipment only with a Tractor equipped with an approved roll-over-protective system (ROPS). Always wear seat belts. Death or serious injury could result from falling off the tractor, particularly during a turnover when the operator could be pinned under the ROPS. (SG-7) str



### 3.2 Tractor Horsepower

The power required to operate a implement is determined by the tractor PTO horsepower. For most operating conditions, the PT417/417H requires a tractor with at least 22hp. Operating the implement with a tractor that does not have adequate power may damage the tractor engine. Exceeding the recommended horsepower may cause damage by overpowering the unit in heavy operating conditions.

### 3.3 Drawbar - Pull-Type Mower

For pull-type mowers (540 and 1000 RPM) equipped with an equal-angle driveline, the tractor drawbar must be positioned at a 14" distance from the hitch point to the PTO shaft end for proper operation and minimal wear to the driveline and tractor.

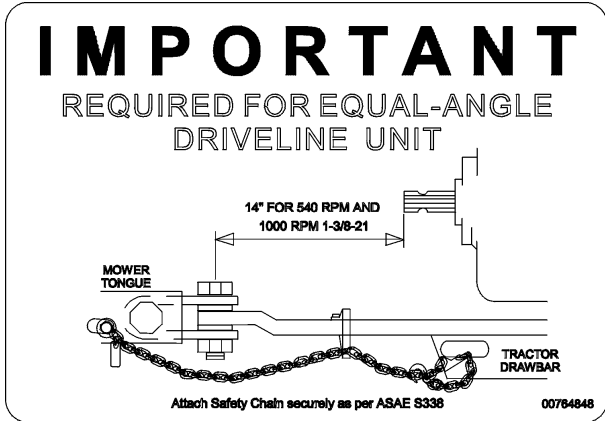

# OPERATION

## 3.4 Front End Weight

A minimum of 20% total tractor weight must be maintained on the tractor front end at all times. Front end weight is critical to maintain steering control and to prevent the tractor from rearing up while driving. If the front end is too light, add weight until a minimum of 20% total weight is reached on the front tires. Front weights and weight carriers can be purchased through an authorized tractor dealership. OPS-U-0005 str

## 4.GETTING ON AND OFF THE TRACTOR

Before getting onto the tractor, the operator must read and completely understand the implement and tractor operator manuals. If any part of either manual is not completely understood, consult an authorized dealer for a complete explanation. OPS-U- 0007str



**WARNING**

Do not mount or dismount the Tractor while the tractor is moving. Mount the Tractor only when the Tractor and all moving parts are completely stopped. Dismounting a moving power unit can result in a crushing hazard that can cause death or serious injury. (SG-12) str



### 4.1 Boarding the Tractor

Use both hands and equipped handrails and steps for support when boarding the tractor. Never use control levers for support when mounting the tractor. Seat yourself in the operator's seat and secure the seat belt around you.

Never allow passengers to ride on the tractor or attached equipment. Riders can easily fall off and be seriously injured or killed from falling off and being ran over. It is the operator's responsibility to forbid all extra riders at all times. OPS-U- 0008str



**DANGER**

Never allow children to operate, ride on, or come close to the Tractor or Implement. Usually, 16-17 year-old children who are mature and responsible can operate the implement with adult supervision, if they have read and understand the Operator's Manuals, been trained in proper operation of the tractor and Implement, and are physically large enough to reach and operate the controls easily. (SG-11) str



**DANGER**

Never allow children or other persons to ride on the Tractor or Implement. Falling off can result in death or serious injury. (SG-10)str



### 4.2 Dismounting the Tractor

Before dismounting, park the tractor and implement on a reasonably level surface, apply the parking brake, idle the engine down, disengage the PTO, and lower the implement to the ground. Shut down the tractor engine according to the operator's manual, remove the key, and wait for all motion to completely stop. Never leave the seat until the tractor, its engine and all moving parts have come to a complete stop.

Use hand rails and steps when exiting the tractor. Be careful of your step and use extra caution when mud, ice, snow or other matter has accumulated on the steps or hand rails. Use all handrails and steps for support and never rush or jump off the tractor. OPS-U- 0009 str

# OPERATION



BEFORE leaving the tractor seat lower the implement, set the parking brake and/or set the tractor transmission in parking gear, disengage the PTO, stop the engine, remove the key, and wait for all moving parts to stop. Place the tractor shift lever into a low range or parking gear to prevent the tractor from rolling. Never dismount a Tractor that is moving or while the engine is running. Operate the Tractor controls from the tractor seat only.

(SG-9)str

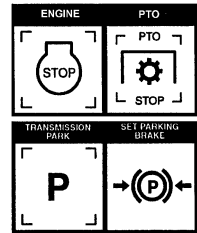

## 5. STARTING THE TRACTOR

The operator must have a complete understanding of the placement, function, and operational use of all tractor controls before starting the tractor. Review the tractor operator's manual and consult an authorized dealer for tractor operation instructions if needed.

### Essential Tractor Controls:

- Locate the light control switch
- Locate the engine shut off control
- Locate the brake pedals and the clutch
- Locate the PTO control
- Locate the 3-point hitch control lever
- Locate the hydraulic remote control levers

### Before starting the tractor ensure the following:

- Conduct all pre-start operation inspection and service according to the tractor operator's manual.
- Make sure all guards, shields, and other safety devices are securely in place.
- The parking brake is on.
- The PTO control lever is disengaged.
- The 3-point hitch control lever is in the lowered position.
- The hydraulic remote control levers are in the neutral position.
- The tractor transmission levers are in park or neutral.

Refer to the tractor owner's manual for tractor starting procedures. Only start the tractor while seated and belted in the tractor operator's seat. Never bypass the ignition switch by short circuiting the starter solenoid. After the tractor engine is running, avoid accidental contact with the tractor transmission to prevent sudden and unexpected tractor movement. OPS-U-0028str



Never run the Tractor engine in a closed building or without adequate ventilation. The exhaust fumes can be hazardous to your health. (SG-23) str



Start tractor only when properly seated in the Tractor seat. Starting a tractor in gear can result in death or serious injury. Read the Tractor operators manual for proper starting instructions. (SG-13) str



# OPERATION

## 6. CONNECTING THE HAY TEDDER TO THE TRACTOR

Use extreme caution when connecting the hay tedder to the tractor. The hay tedder should be securely resting at ground level or setting on blocks. Keep hands and feet from under the hay tedder and clear of pinch points between the tractor hitch arms and lift side rotors. OPS-HT-0011 str



Always shut the Tractor completely down, place the transmission in park, and set the parking brake before you or anyone else attempts to connect or disconnect the Implement and Tractor hitches. (S3PT-15) str

### 6.1 Connecting the Hay Tedder

The attachment of pull-type machine to the tractor is very simple, as it is only necessary to couple the drawbar 5 to the tractor hitch using a pin of appropriate size, strength and shape. Always use extreme care when reversing the tractor towards the machine.

Once the machine is hitched to the tractor, the parking stand 6 must be raised from the parking position. To do this, remove clip 8 and pin 7, and rotate the parking stand so that it is parallel with the drawbar 5. Fasten into the new position using pin 7 and clip 8. At this point quick-release coupling 9 should be attached to the tractor coupling 10. Fasten rope 11 to lever 12

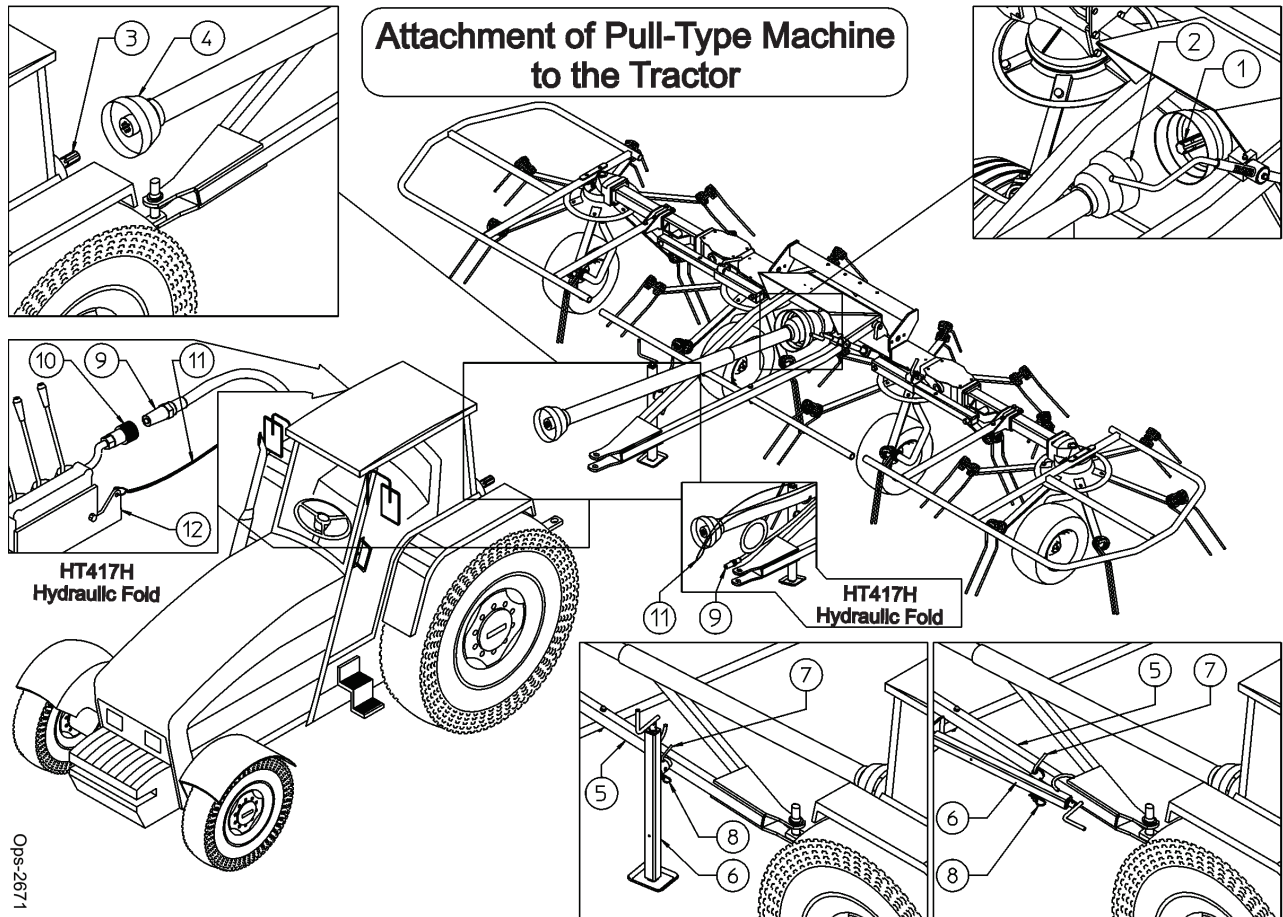

Ops-2671

# OPERATION

## **6.2 Safety Tow Chain**

If the implement is towed on a public roadway, a safety chain with tensile strength equal to or greater than the gross weight of the implement must be connected between the tractor and implement. This will help control the implement in the event the tongue becomes disconnected from the drawbar. Make sure the chain is attached to a secure location on the tractor and not to an intermediate support.

After connecting both ends of the safety chain, drive the tractor to the right and left to check for proper chain length. Adjust length as necessary and allow only enough slack in the chain to make a maximum turn in both directions. When not in use, store the safety chain to protect it from mud or standing water by wrapping the chain around the tongue. Replace the safety chain if one or more links or end fittings are broken, stretched or otherwise damaged or deformed. *OPS-U-0039 str*



Never work under the Implement, the framework, or any lifted component unless the Implement is securely supported or blocked up to prevent sudden or inadvertent falling which could cause death or serious injury. (SG-14)str



## **7. DRIVELINE ATTACHMENT**

The driveline yoke and tractor PTO shaft must be dirt free and greased for attachment.

To connect the tedder driveline to the tractor PTO output shaft, pull the driveline yoke collar back and align the grooves and splines of the yoke with those of the PTO shaft. Push the driveline yoke onto the PTO shaft, release the locking collar, and position the yoke until the locking collar balls are seated onto the PTO shaft. Push and pull the driveline back and forth several times to ensure a secure attachment. *OPS-HT-0003 str*

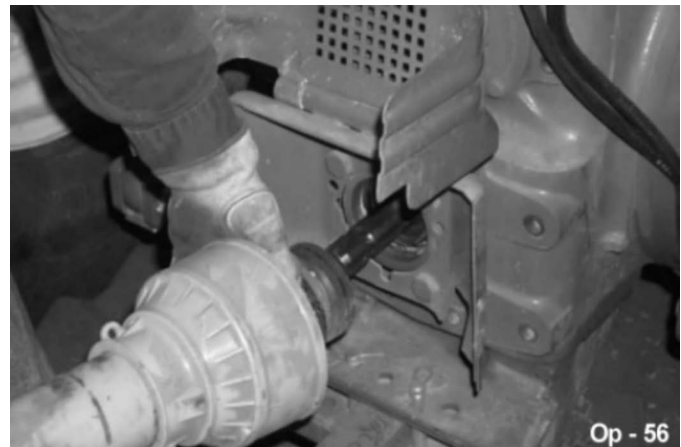

# OPERATION

OPERATION

## 7.1 Driveline Length Check

When fitting the hay tedder to the tractor, the driveline must be inspected to ensure that it is connected correctly both at the tractor end and at the implements end. If a safety system is provided, this should be fitted to the machine end, not to the tractor end.

During both transport and use, avoid conditions where the Driveline transmission shaft is extended to the maximum. In all working conditions, the telescopic tubes must overlap by at least  $\frac{1}{3}$  of their length. **Figure OP-224.**

Conversely, when the driveline shaft is contracted to the maximum, there should still be a gap of approximately 2" (50 mm). **Figure OP-225.**

Take particular care when connecting the two Driveline shaft end forks and make sure that they are fully secured. This is achieved by inserting the safety pins and bolts (1) in the special slots (2) on the power takeoff shafts on both the tractor and implement ends. **Figure OP-226.**

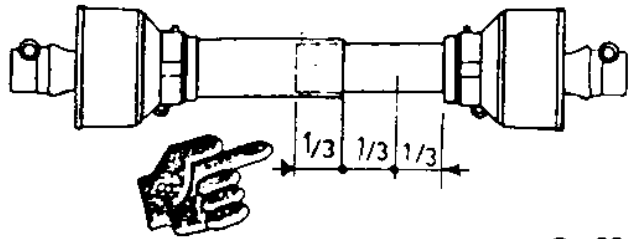

Op-224

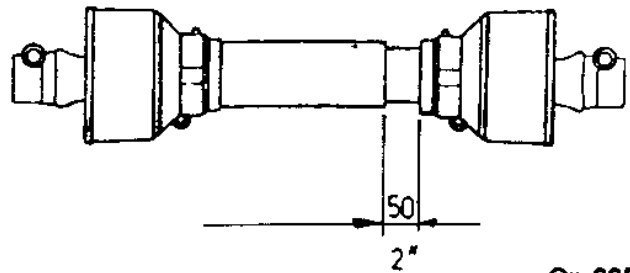

Op-225

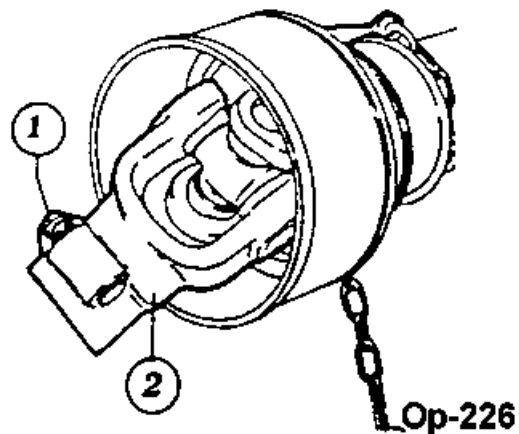

Op-226



# OPERATION

## **8. PRE-OPERATION INSPECTION AND SERVICE**

Before each use, a pre-operation inspection and service of the implement and tractor must be performed. This includes routine maintenance and scheduled lubrication, inspecting that all safety devices are equipped and functional, and performing needed repairs. DO NOT operate the unit if the pre-operation inspection reveals any condition affecting safe operation. Perform repairs and replacement of damaged and missing parts as soon as noticed. By performing a thorough pre-operation inspection and service, valuable down time and repair cost can be avoided. OPS-U-0029str



Periodically inspect all moving parts for wear and replace when necessary with authorized service parts. Look for loose fasteners, worn or broken parts, and leaky or loose fittings. Make sure all pins have cotter pins and washers. Serious injury may occur from not maintaining this machine in good working order. (SG-21 )str



### **8.1 Tractor Pre-Operation Inspection/Service**

Refer to the tractor operator's manual to ensure a complete pre-operation inspection and scheduled service is performed according to the manufacturer's recommendations. The following are some of the items that require daily service and inspection:

- Tire condition/air pressure
- Wheel lug bolts
- Steering linkage
- PTO shield
- SMV sign is clean and visible
- Tractor's lights are clean and functional
- Tractor Seat belt is in good condition
- ROPS is in the raised position
- No tractor oil leaks
- Radiator free of debris
- Engine oil level and condition
- Engine coolant level and condition
- Power brake fluid level
- Power steering fluid level
- Fuel condition and level
- Sufficient lubrication at all lube points
- Air filter condition OPS-U-0030 str



# OPERATION

## **8.2 Hay Tedder Pre-Operation Inspection/Service**

Before each use, a complete inspection and service is required to ensure the hay tedder is in a good and safe working condition. Damaged and/or broken parts should be repaired and/or replaced immediately. To ensure the hay tedder is ready for operation, conduct the following. *OPS-HT-0020 str*

The operator's manual and safety signs affixed on the unit contain important instructions on the safe and proper use of the equipment. Maintain these important safety features on the implement in good condition to ensure the information is available to the operator at all times.

- Ensure the manual canister is secured to the equipment with the operator's manual inside.
- Ensure all safety signs are in place and legible. Replace missing, damaged, and illegible decals. *OPS-U- 0011 str*



# OPERATION

## HAY TEDDER PRE-OPERATION INSPECTION



Mower ID# \_\_\_\_\_ Date: \_\_\_\_\_  
 Make: \_\_\_\_\_ Shift: \_\_\_\_\_



Before conducting the inspection, make sure the tractor engine is off, all rotation has stopped and the tractor is in park with the parking brake engaged. Make sure the tedder is resting on the ground or securely blocked up and all hydraulic pressure has been relieved.

Item	Condition at Start of Shift	Specific Comments if not OK
The Operator's Manual is in the canister on the Hay Tedder		
All safety decals are in place and legible		
The Tongue/Hitch connection bolts & pins are tight		
There are no cracks in the Tongue or Hitch		
There are no cracks in Loader Arms or Mounts		
The Tow Chain is secured to the Tractor & Hay Tedder		
Driveline/Gearbox Shields are in good condition		
Driveline Clutches are in good condition, not frozen		
Driveline Telescoping Members & U-Joints are lubricated		
Driveline Yokes are securely attached to PTO & Tiller		
Gearbox Mounting Bolts are tight		
Gearbox Oil is at the proper level		
The Wing connection bolts & pins are tight		
Transport locks & retaining chains are in good condition		
Rake spokes are in good condition & securely		
Rake Wheels are securely attached to the frame members		
The Hydraulic Cylinders are in good condition		
The Hydraulic Cylinder pins are in place & retained		
There are no leaking or damaged hoses		
There is no evidence of hydraulic leaks		
The tires & wheel(s) are in good condition		
Wheel lug nuts are tight		

Operator's Signature: \_\_\_\_\_

**DO NOT OPERATE an UNSAFE TRACTOR or IMPLEMENT**

**OPERATION**

# OPERATION

## TRACTOR PRE-OPERATION INSPECTION



Tractor ID# \_\_\_\_\_ Make: \_\_\_\_\_

Date: \_\_\_\_\_ Shaft: \_\_\_\_\_



Before conducting the inspection, make sure the tractor engine is off, all rotation has stopped and the tractor is in park with the parking brake engaged. Make sure the implement is resting on the ground or securely blocked up and all hydraulic pressure has been relieved.

**OPERATION**

Item	Condition at Start of Shift	Specific Comments if not OK
The flashing lights function properly		
The SMV Sign is clean and visible		
The tires are in good condition with proper pressure		
The wheel lug bolts are tight		
The tractor brakes are in good condition		
The steering linkage is in good condition		
There are no visible oil leaks		
The hydraulic controls function properly		
The ROPS or ROPS Cab is in good condition		
The seatbelt is in place and in good condition		
The 3-point hitch is in good condition		
The drawbar pins are securely in place		
The PTO master shield is in place		
The engine oil level is full		
The brake fluid level is full		
The power steering fluid level is full		
The fuel level is adequate		
The engine coolant fluid level is full		
The radiator is free of debris		
The air filter is in good condition		

Operator's Signature: \_\_\_\_\_

**DO NOT OPERATE an UNSAFE TRACTOR or IMPLEMENT**

# OPERATION

## 9. DRIVING THE TRACTOR AND IMPLEMENT

Safe tractor transport requires the operator possess a thorough knowledge of the model being operated and precautions to take while driving with an attached implement. Ensure the tractor has the capacity to handle the weight of the implement and the tractor operating controls are set for safe transport. To ensure safety while driving the tractor with an attached implement, review the following. OPS-U- 0012str

### **DANGER**

This Implement may be wider than the Tractor. Be careful when operating or transporting this equipment to prevent the Implement from running into or striking sign posts, guard rails, concrete abutments or other solid objects. Such an impact could cause the Implement and Tractor to pivot violently resulting in loss of steering control, death, or serious injury. Never allow the Implement to contact obstacles. (S3PT-12)str

### **WARNING**

Transport only at speeds where you can maintain control of the equipment. Serious accidents and injuries can result from operating this equipment at high speeds. Understand the Tractor and Implement and how it handles before transporting on streets and highways. Make sure the Tractor steering and brakes are in good condition and operate properly.



Before transporting the Tractor and Implement, determine the proper transport speeds for you and the equipment. Make sure you abide by the following rules:

Test the tractor at a slow speed and increase the speed slowly. Apply the Brakes smoothly to determine the stopping characteristics of the Tractor and Implement. As you increase the speed of the Tractor the stopping distance increases. Determine the maximum transport speed not to exceed 20 mph (30 kph) for transporting this equipment.

Test the equipment at a slow speed in turns. Increase the speed through the turn only after you determine that the equipment can be operated at a higher speed. Use extreme care and reduce your speed when turning sharply to prevent the tractor and implement from turning over. Determine the maximum turning speed for you and this equipment before operating on roads or uneven ground.



Only transport the Tractor and Implement at the speeds which allow you to properly control the equipment.

Be aware of the operating conditions. Do not operate the Tractor with weak or faulty brakes or worn tires. When operating down a hill or on wet or rain slick roads, the braking distance increases: use extreme care and reduce your speed. When operating in traffic always use the Tractor's flashing warning lights and reduce your speed. Be aware of traffic around you and watch out for the other guy. (SG-19)str

# OPERATION

## **9.1 Starting the Tractor**

The procedure to start the tractor is model specific. Refer to the tractor operator's manual for starting procedures for your particular tractor. Consult an authorized dealer if the starting procedure is unclear. Ensure the 3-point control lever is in the lowered position and the PTO is disengaged before starting the tractor. OPS-U-0033str



## **9.2 Brake and Differential Lock Setting**

Make sure the tractor brakes are in good operating condition. Tractor brakes can be set to operate independently allowing single rear wheel braking action or locked together to provide simultaneous rear wheel braking. FOR MOST DRIVING AND OPERATING CONDITIONS, THE BRAKE PEDALS SHOULD BE LOCKED TOGETHER TO PROVIDE THE MOST EFFECTIVE BRAKING ACTION.

Always disengage the tractor differential lock when turning. When engaged the differential lock will prevent or limit the tractor from turning. During normal cutting conditions, locking the differential provides no benefit and should not be used.

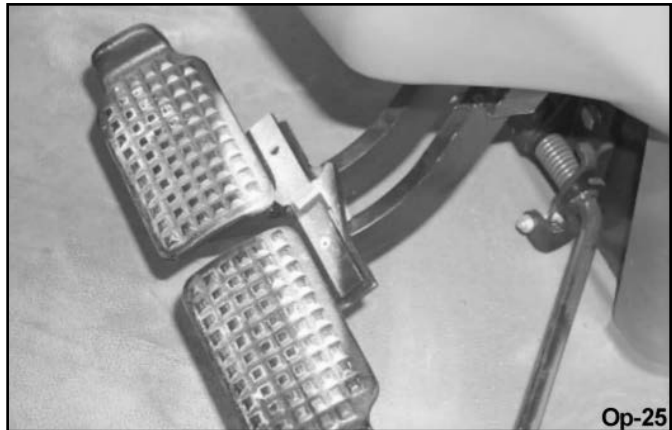

### **WARNING**

Be aware of the operating conditions. Do not operate the Tractor with weak or faulty brakes. When operating down a hill or on wet or rain slick roads, the braking distance increases. Use extreme care and reduce your speed in these conditions. When operating in traffic, always use the Tractor's flashing warning lights and reduce your speed. Be aware of traffic around you and watch out for the other guy. OPS-U- 0013 str

# OPERATION

## **9.3 Driving the Tractor and Hay Tedder**

Start off driving at a slow speed and gradually increase your speed while maintaining complete control of the tractor and implement. Moving slowly at first will also prevent the tractor from rearing up and loss of steering control. The tractor should never be operated at speeds that cannot be safely handled or which will prevent the operator from stopping quickly during an emergency. If the power steering or engine ceases operating, stop the tractor immediately as the tractor will be difficult to control.

Perform turns with the tractor and implement at slow speeds to determine how the tractor with an attached implement handles a turn. Determine the safe speed to maintain proper control of the tractor when making turns. When turning with a towed implement, the overall working length of the unit is increased. Allow additional clearance for the implement when turning.

To avoid overturns, drive the tractor with care and at safe speeds, especially when operating over rough ground, crossing ditches or slopes, and turning corners. Tractor wheel tread spacing should be increased when working on inclines or rough ground to reduce the possibility of tipping.

Use extreme caution when operating on steep slopes. Keep the tractor in a low gear when going downhill. DO NOT coast or free-wheel downhill. *OPS-HT-0037\_A str*

## **10. OPERATING THE TRACTOR AND IMPLEMENT**

**THE OPERATOR MUST COMPLETELY UNDERSTAND HOW TO OPERATE THE TRACTOR AND IMPLEMENT AND ALL CONTROLS BEFORE ATTEMPTING TO OPERATE.**

The operator must read and understand the Safety and Operation Sections of the implement and tractor operator's manuals. These manuals must be read and explained to any operator who cannot read. Never allow someone to operate the implement and tractor without complete operating instructions.

Before starting any operation, the operator must become familiar with the area to be worked in and any obstacles and hazards contained within to ensure safety to the operator, bystanders, and equipment. Special attention should be paid to foreign debris, rough terrain, steep slopes, and passersby and animals in the area. *OPS-U- 0015 str*

# OPERATION

OPERATION

## 10.1 Operating the Hay Tedder in the Field (Manual Fold)

For the HT417/HT417H manual fold, lateral arms 1 & 2 should be lowered beforehand. To do this, rotate pin 4 so that spring pins 3 on it, slides over tab "C", causing pin 4 to exit from the hole in the inside pipe of the strut assembly (RH and LH side). Now lower lateral arms 1-2 by pulling on guards "A-B".

### USE IN THE FIELD

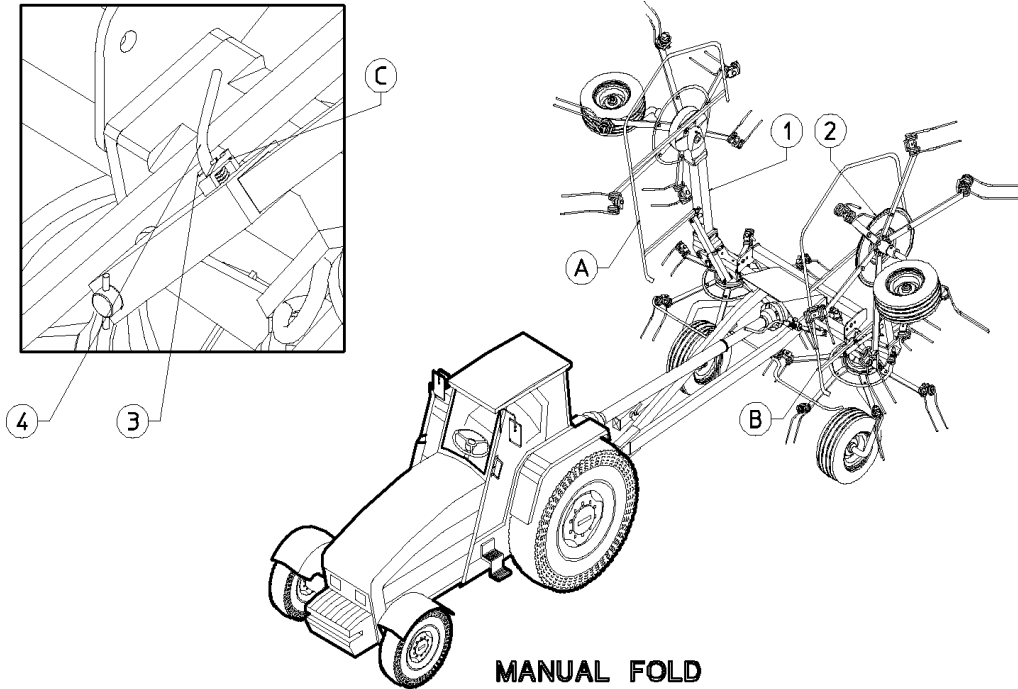

## 10.2 Adjustment For Correct Working Position

These machines are very easily adjusted. For best operation, the tines 1 on the front side of the machine should brush the ground. To obtain this, turn the adjustment crank 2.

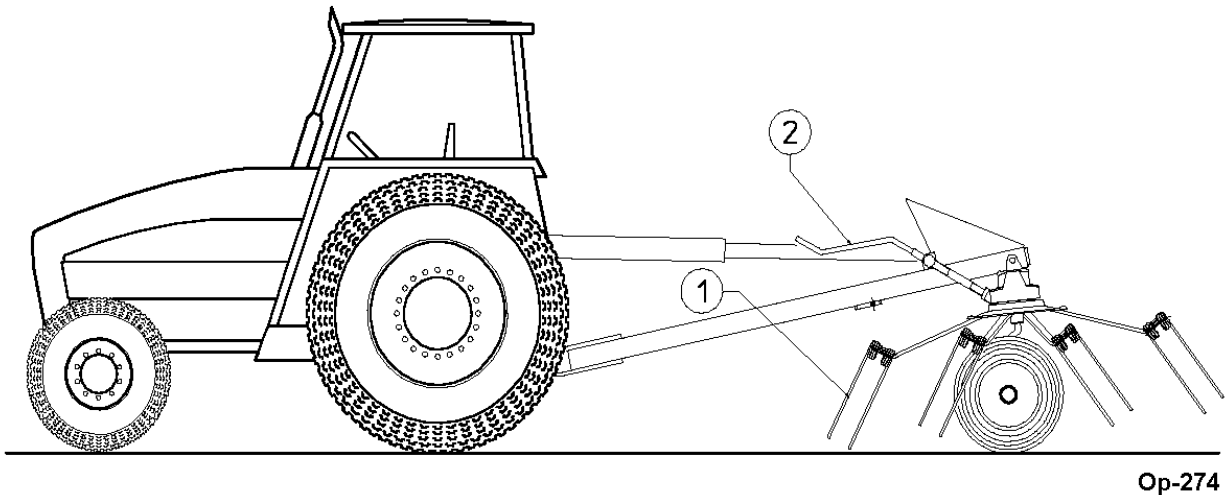



# OPERATION

## **10.3 PTO RPM and Ground Speed**

Ground speed will depend upon the height, type, and density of vegetation. Recommended speed for efficient performance is 5 mph. Operate the implement at its 350-450 PTO RPM (540 MAX) rated speed to maintain good operation. Refer to the tractor operator's manual or the tractor instrument panel for the engine speed and gear to provide the required PTO and desired ground speed. Make sure that the implement is operating at its full rated speed before entering into use. If it becomes necessary to temporarily regulate engine speed, increase or decrease the throttle gradually.

Ground speed is achieved by transmission gear selection and not by the engine operating speed. The operator may be required to experiment with several gear range combinations to determine the best gear and range which provides the most ideal performance from the implement and most efficient tractor operation. As the severity of conditions increase, the ground speed should be decreased by selecting a lower gear to maintain the proper operating PTO speed. *OPS-HT-0025 str*

## **10.4 Engaging the Power Take Off (PTO)**

Before engaging the PTO, make certain that the area is clear of bystanders and passersby. The implement must be completely lowered and the deck positioned at a safe operating height. NEVER engage the PTO with the implement in the raised position.

Set the tractor engine speed at approximately 1,000 RPM before engaging the PTO. Shift the PTO control to the on position, and slowly increase the engine speed until the PTO is operating at 350-450 RPM (540 MAX). If you hear unusual noises or see or feel abnormal vibrations, disengage the PTO immediately. Inspect the implement to determine the cause of the noise or vibration and repair the abnormality. *OPS-HT- 0017 str*

## **10.5 Shutting Down the Implement**

To shut down the implement, first bring the tractor to a complete stop. Then slow down the implement by reducing the engine speed before disengaging the PTO. Wait for all motion to stop before proceeding to drive or shut down the tractor.

Park the tractor on a level surface, place the transmission in park or neutral and apply the parking brake, lower the attached implement to the ground, shut down the engine, remove the key, and wait for all motion to come to a complete stop before exiting the tractor. *OPS-HT- 0016\_A str*

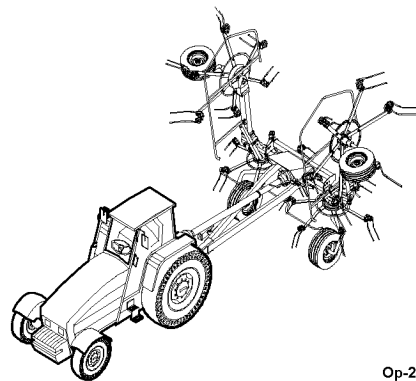

# OPERATION

## **11. DISCONNECTING THE HAY TEDDER FROM THE TRACTOR**

Before disconnecting the hay tedder, the PTO must be disengaged and all movement must cease. Move the hay tedder to a level storage location and lower the unit to the ground. If the hay tedder is not resting securely on the ground, block the hay tedder up securely before attempting to disconnect it from the tractor.

Use extreme care to keep feet and hands from under the hay tedder and clear of any pinch points. *OPS- HT-0051 str*



Always shut the Tractor completely down, place the transmission in park, and set the parking brake before you or anyone else attempts to connect or disconnect the Implement and Tractor hitches. (S3PT-15) str

OPERATION

Before disconnecting the machine from the tractor, use the hydraulic lever to unfold and lower the machine completely, apply the brake and shut off the tractor. Relieve hydraulic pressure by moving the control levers back and forth several times. Dismount from the tractor and place the parking stand in the vertical position. Turn the crank to raise the machine from the drawbar so that the hitch pin may be removed from the tractor. Disconnect the quick-release coupling. Disconnect the driveline and rest on the driveline holder. The tractor can now be moved away. *OPS-HT-0052 str*

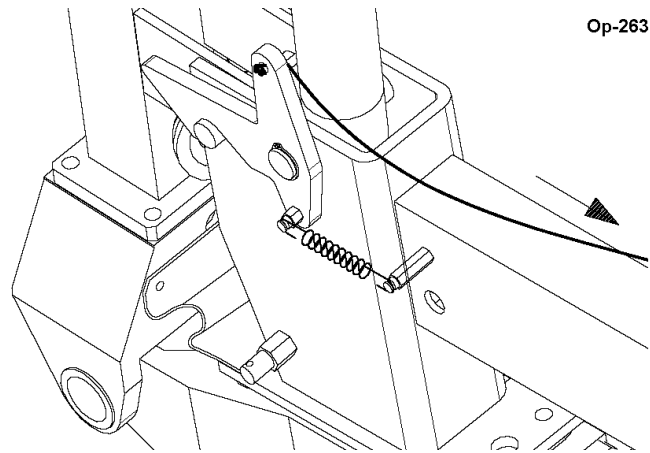

# OPERATION

## **12. HAY TEDDER STORAGE**

Properly preparing and storing the hay tedder at the end of the season is critical to maintaining its appearance and to help ensure years of dependable service. The following are suggested storage procedures:

- Thoroughly clean all debris off the implement to prevent damage from decaying grass.
- Lubricate all grease points and fill gearbox oil levels as detailed in the maintenance section
- Tighten all bolts and pins to the recommended torque.
- Check worn and damaged parts. Perform repairs and make replacements immediately so that the implement will be ready for use at the start of the next season.
- Store the hay tedder in a clean, dry place with the housing resting securely on blocks or at ground level.
- Use spray touch-up enamel where necessary to prevent rust and maintain the appearance of the hay tedder.

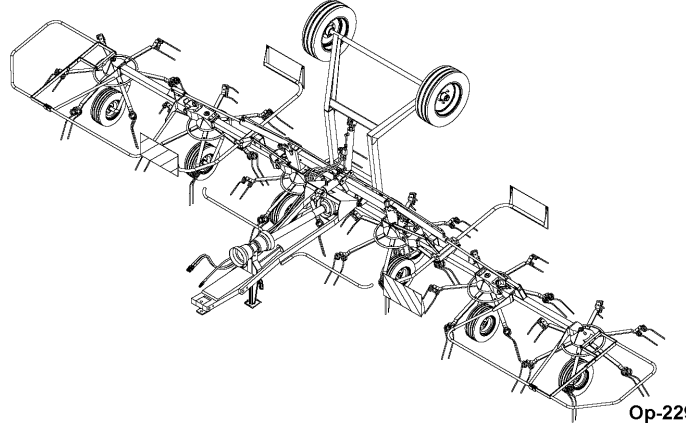

OPERATION

Store tedder with the wings lowered and the main transport wheels lowered. *OPS-HT-0053 str*



Never allow children to play on or around Tractor or Implement. Children can slip or fall off the Equipment and be killed or injured. Inadvertent contact with controls can cause the Implement to shift or fall crushing themselves or others. (SG-25) str

# OPERATION

## 13. TRANSPORTING THE TRACTOR AND IMPLEMENT

Inherent hazards of operating the tractor and implement and the possibility of accidents are not left behind when you finish working in an area. Therefore, the operator must employ good judgment and safe operation practices when transporting the tractor and implement between locations. By using good judgment and following safe transport procedures, the possibility of accidents while moving between locations can be substantially minimized. *OPS-U- 0017str*



Never allow children or other persons to ride on the Tractor or Implement. Falling off can result in death or serious injury. *(SG-10)str*



OPERATION

### 13.1 Transport Instructions for Manual Fold

Before transporting the implement, it is necessary raise lateral arms 1 & 2. To do this, first check that spring pin 4, is not touching tab C (RH and LH side). Then raise lateral arms 1 & 2 by pulling on guards A-B until pin 4 of the spring strut assembly enters hole D (RH and LH side) of the inside pipe of the strut assembly. *OPS-HT-0055\_A str*

### TRANSPORT INTRUCTIONS FOR MANUAL FOLD

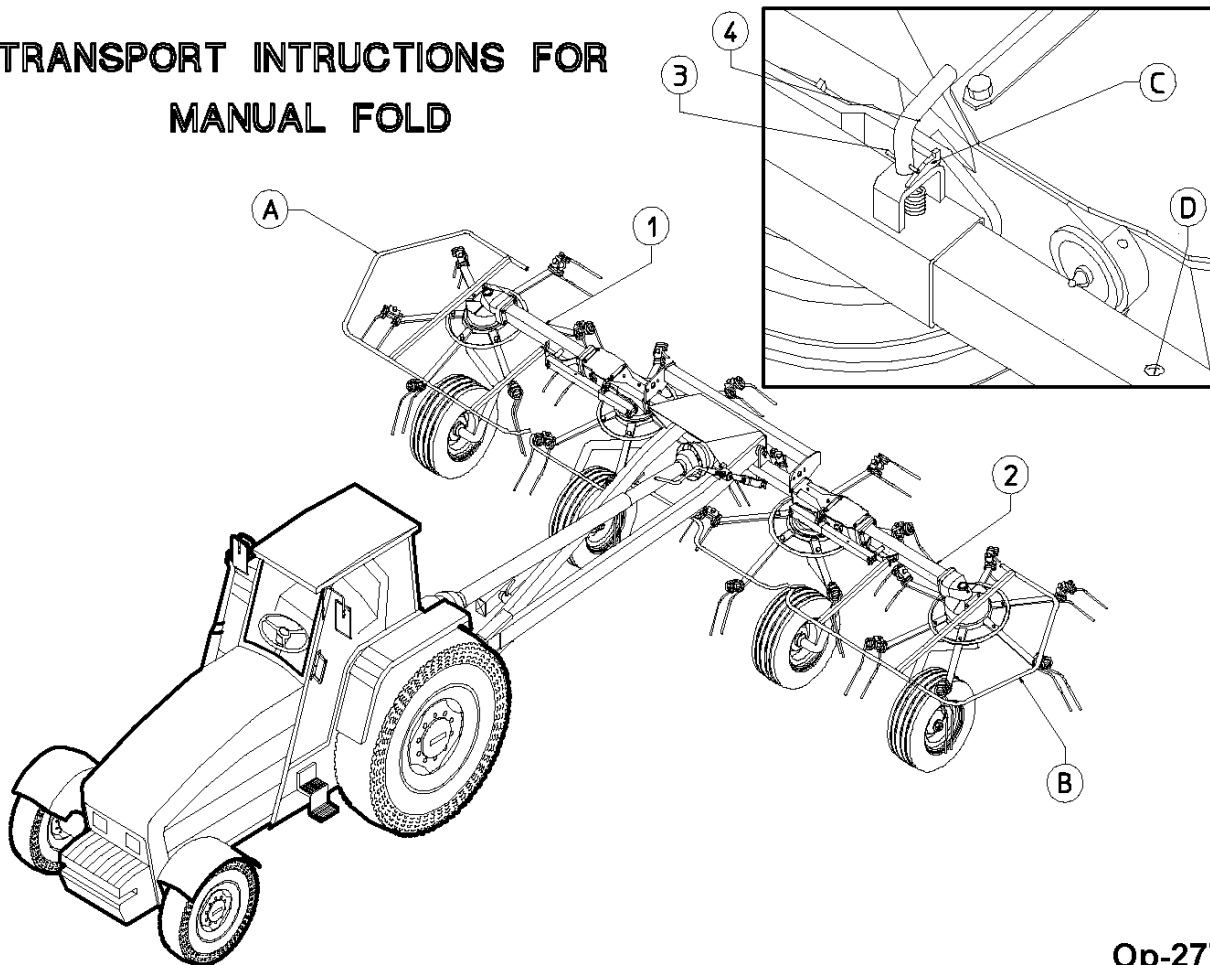

Op-277

# OPERATION

## 13.2 Transport Instructions for Hydraulic Fold

Before transporting, the side arms 1 & 2 must be raised. To do this move the distributor lever 3, sending fluid through hoses 4 & 5 to cylinders 6 & 7, which will close, lifting the side arms 1 & 2. Before proceeding with transport, make sure that catch 9 is firmly hooked on pin 10 (RH and LH side) in order to guarantee safety while the machine is being transported. . OPS-HT-0055\_B str

### TRANSPORT INTRUCTIONS FOR HYDRAULIC FOLD

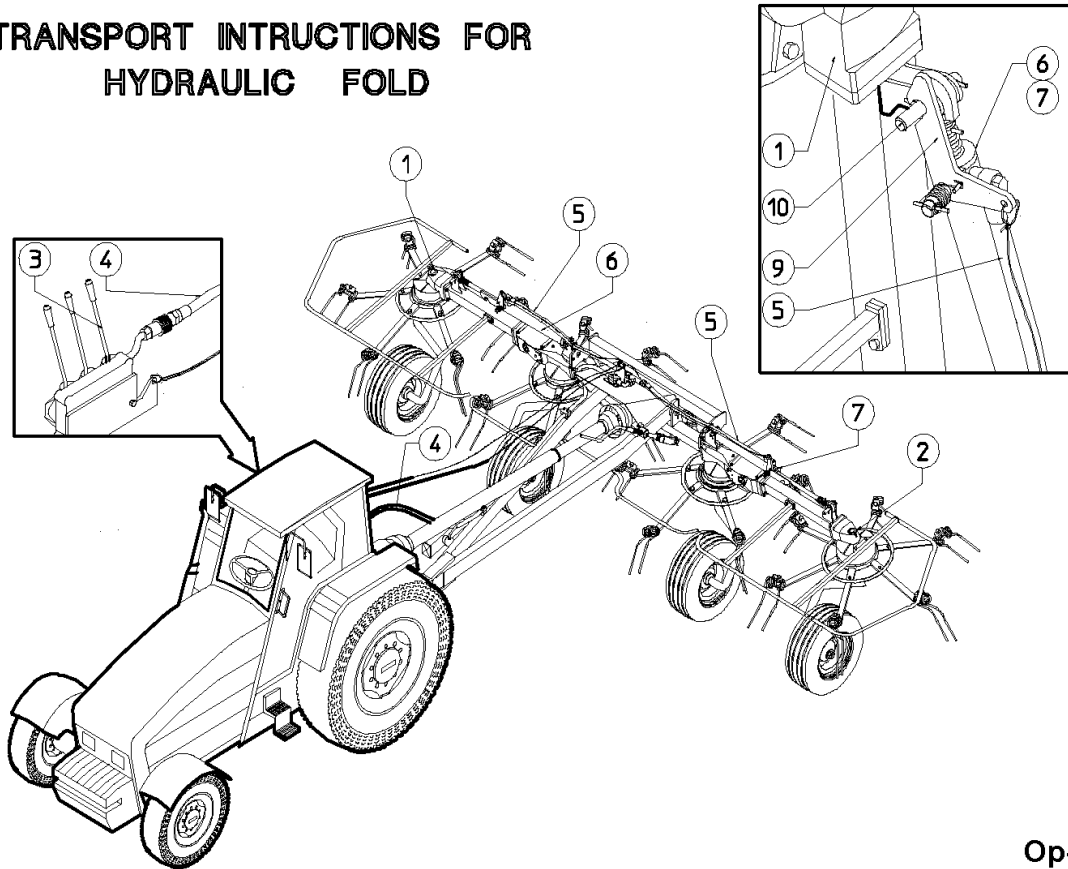

**NOTE:** The machine ready for transport should appear as show on Fig. The hydraulic fold also show this configuration

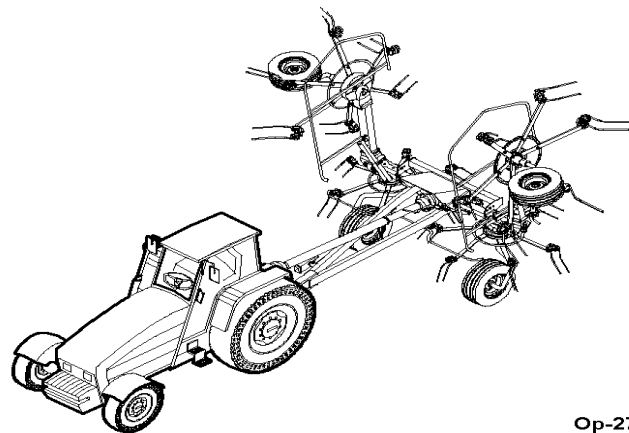

# OPERATION

OPERATION

Before transporting the tractor on a public roadway or boarding a trailer for transport, the tractor brake pedals should be locked together. Locking the pedals ensures that both wheels brake simultaneously while stopping, especially when making an emergency stop.

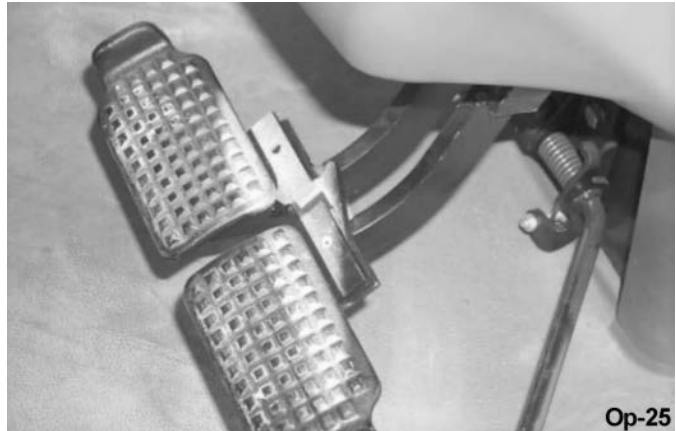

Use extreme caution and avoid hard applications of the tractor brakes when towing heavy loads at road speeds. Never tow the implement at speeds greater than 20 MPH (32 kph). *OPS-U- 0018 str*

## 14. TRANSPORTING ON PUBLIC ROADWAYS

Extreme caution should be used when transporting the tractor and implement on public roadways. The tractor must be equipped with all required safety warning features including a SMV emblem and flashing warning lights to alert drivers of the tractor's presence. Remember that roadways are primarily designed for automotive drivers and most drivers will not be looking out for you, therefore, you must look out for them. Check your side view mirrors frequently and remember that vehicles will approach quickly because of the tractor's slower speed. Be extremely cautious when the piece of equipment that you are towing is wider than the tractor tire width and/or extends beyond your lane of the road.

Make sure that a proper size safety tow chain is secured between the tractor and implement before entering a public road. *OPS-U- 0019 str*



Only tow the Implement behind a properly sized and equipped Tractor which exceeds the weight of the Implement by at least 20%. DO NOT tow the Implement behind a truck or other type of vehicle. Never tow the Implement and another Implement connected in tandem. Never tow the Implement at speeds over 20 MPH. *(STI-06)str*



Never allow children or other persons to ride on the Tractor or Implement. Falling off can result in death or serious injury. *(SG-10)str*



Make certain that the "Slow Moving Vehicle" (SMV) sign is installed in such a way as to be clearly visible and legible. When transporting the Equipment use the Tractor flashing warning lights and follow all local traffic regulations. *(SG-6)str*

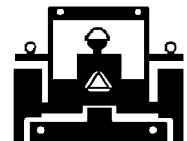

# OPERATION

The SMV (Slow-Moving Vehicle) emblem is universal symbol used to alert drivers of the presence of equipment traveling on roadways at a slow speed. SMV signs are a triangular bright orange with reflective red trim for both easy day and night visibility. Make sure the SMV sign is clean and visible from the rear of the unit before transporting the tractor and implement on a public roadway. Replace the SMV emblem if faded, damaged, or no longer reflective. *OPS-U- 0020str*



Make sure that all tractor flashing warning lights, headlights, and brake/tail lights are functioning properly before proceeding onto public roads. While newer model tractors have plenty of lighting to provide warning signals and operating lighting, most older models are only equipped with operating lights. Consult an authorized tractor dealer for lighting kits and modifications available to upgrade the lighting on older tractor models. *OPS-U- 0021str*



When operating on public roads, have consideration for other road users. Pull to the side of the road occasionally to allow all following traffic to pass. Do not exceed the legal speed limit set in your country for agricultural tractors. Always stay alert when transporting the tractor and implement on public roads. Use caution and reduce speed if other vehicles or pedestrians are in the area. *OPS-U- 0022 str*



# OPERATION

Reduce speed before turning or applying the brakes. Ensure that both brake pedals are locked together when operating on public roads. *OPS-U-0023 str*

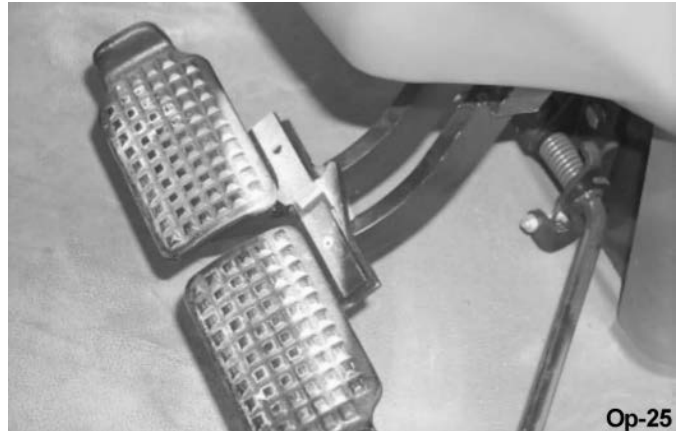

## **14.1 Hauling the Tractor and Implement**

Before transporting a loaded tractor and implement, measure the height and width dimensions and gross weight of the complete loaded unit. Ensure that the load will be in compliance with the legal limits set for the areas that will be traveled through. *OPS-U-0024 str*



Use adequately sized and rated trailers and equipment to transport the tractor and implement. Consult an authorized dealer to determine the proper equipment required. Using adequately sized chains, heavy duty straps, cables and/or binders, securely tie down both the front and rear of the tractor utilizing the proper tie down locations as specified by the tractor manufacturer. *OPS-U- 0025 str*





# **MAINTENANCE SECTION**

Maintenance Section 5-1

# MAINTENANCE

## MAINTENANCE

### GENERAL MAINTENANCE

All cleaning, lubrication, and maintenance operations must be carried out with the machine disconnected from the tractor. In an emergency with the machine still connected to the tractor, turn engine off, apply parking brake, disengage the power takeoff, remove ignition key and wait for all motion to come to a complete stop.

Regular maintenance and proper operation are the basic essentials for a long-term efficiency and safe operation of the machine.

All maintenance should be carried out in an area having the proper equipment readily available and in good condition. This area needs to be always clean and dry and must have enough surrounding space to facilitate operations. Any work must be carried out by a trained person. Contact the dealer nearest you. Respect the warnings and procedures for maintenance and technical assistance given in this manual.

Do not use gasoline, solvents or other flammable liquids as detergents. Use commercial non-flammable and non toxic solvents, authorized by competent bodies.

Do not use compressed air or water at high pressure to clean the machine. If this is unavailable, then wear goggles with side protection and limit the pressure as much as possible. When the work is finished, and with the machine disconnected from the tractor, inspect the check the machine completely.



#### **WARNING**

Never attempt to lubricate, adjust, or remove material from the Implement while it is in motion or while tractor engine is running. (SG-20)str



#### **WARNING**

Relieve hydraulic pressure prior to doing any maintenance or repair work on the Implement. Place the Implement on the ground or securely blocked up, disengage the PTO, and turn off the tractor engine. Push and pull the Remote Cylinder lever in and out several times prior to starting any maintenance or repair work. (S3PT-09)str



#### **WARNING**

Periodically inspect all moving parts for wear and replace when necessary with authorized service parts. Look for loose fasteners, worn or broken parts, and leaky or loose fittings. Make sure all pins have cotter pins and washers. Serious injury may occur from not maintaining this machine in good working order. (SG-21 )str

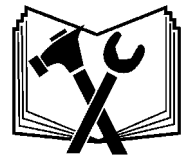

# MAINTENANCE

MAINTENANCE

## LUBRICATION POINTS

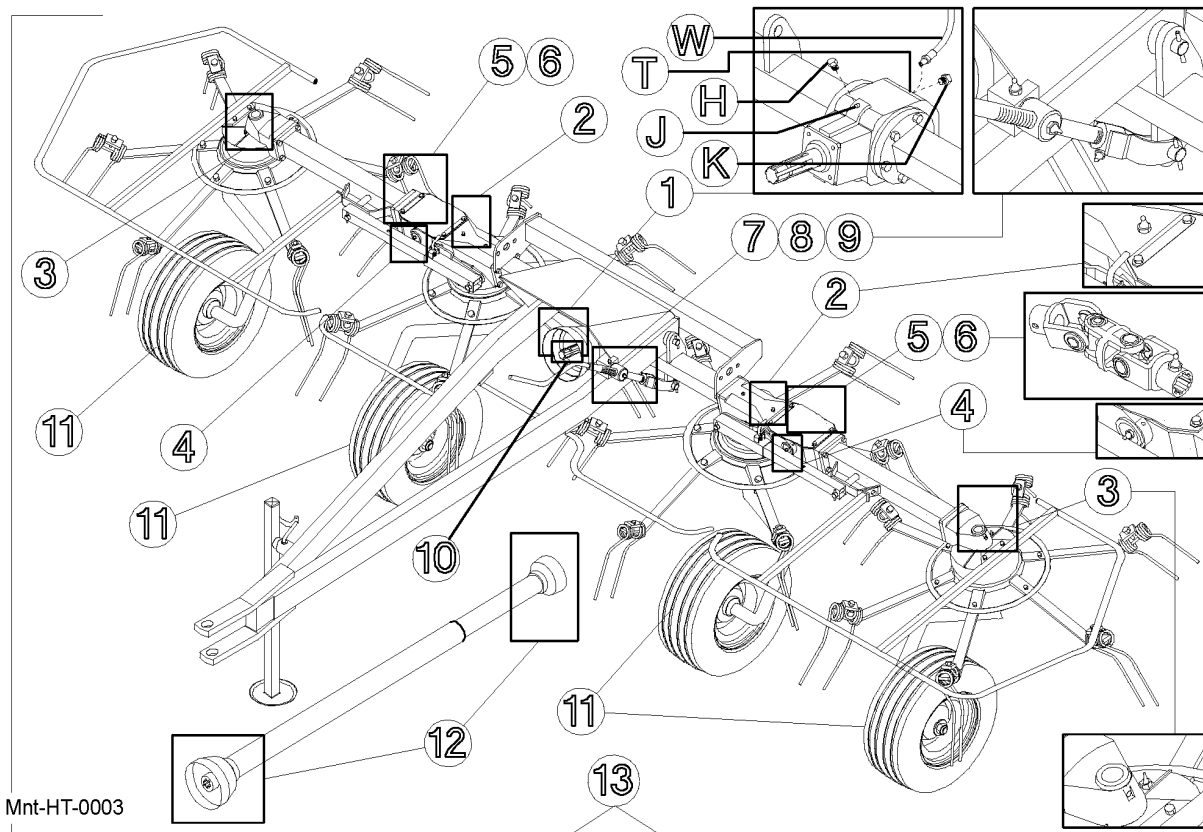

Mnt-HT-0003

ITEM	QTY	DESCRIPTION	OPERATION	FREQUENCY	NOTES
1	1	Gearbox	Lubricate	100 Hours	See Note A
2	2	Central Rotors	Lubricate	50 Hours	See Note A
3	2	Lateral Rotors	Lubricate	50 Hours	See Note A
4	4	Swivel Hinge Pins	Lubricate	50 Hours	See Note A
5	4	Universal Joints	Lubricate	8 Hours	See Note A
6	2	Keyed Coupling Fork	Lubricate	8 Hours	See Note A
7	1	Strut Bushing	Lubricate	8 Hours	See Note A
8	1	Strut Pin	Lubricate	8 Hours	See Note A
9	2	Adjustment Fork	Lubricate	8 Hours	See Note A
10	1	PTO	Clean/Lubricate	See Note B	With Brushes, etc.
11	4	Wheels	Check Pressure	See Note C	Inflate to 35 PSI
12	1	Cardan Shaft	See Driveline Shaft Maintenance		
13	*	General checking of bolts, security pins and split pins to be carried out initially after the first 8 hours of use. Subsequently every 50 hrs and whenever the machine is laid up for extended periods. Grease Type: NGLI 2 EP			

# MAINTENANCE

MAINTENANCE

**NOTE A:** The complete lubrication of housing 1 is done the first time at the manufacturers plant, after which it must be topped up periodically, as according to the lubrication chart. A complete change or fill is necessary only for the replacement and /or repairing of the entire gearbox or internal parts. In this case, it is necessary to: remove caps H-K and inject the grease, using grease pump W, into hole T until the grease comes out of hole K. Then screw caps H-K back into place on center gearbox 1. Use Multi-Purpose Gear Oil.

**NOTE B:** Each time the driveshaft is disconnected and whenever the machine is stopped, we recommended that you clean the power takeoff shaft and replace the protective cover (use additives of a type permitted by anti-pollution regulations).

**NOTE C:** Each time the machine is connected to the tractor.

## Driveline Maintenance

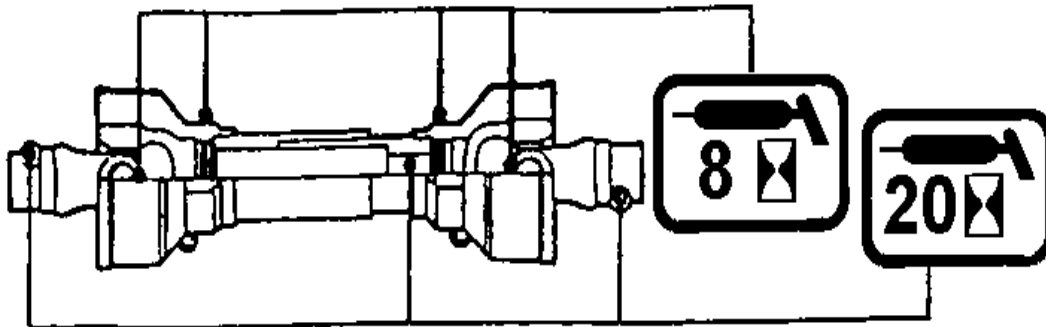

Mnt-HT-0010

## Driveline Dismantle

Turn the two eccentric pins on the ferrule until the protective cone comes free

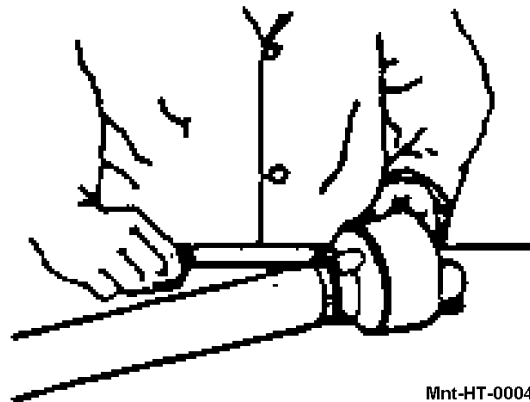

Mnt-HT-0004

# MAINTENANCE

MAINTENANCE

Withdraw the shaft protective guard

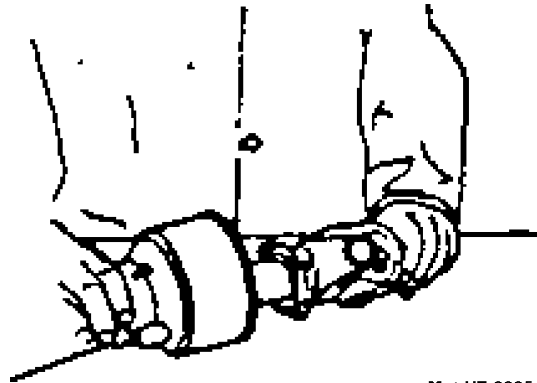

Mnt-HT-0005

Check the condition of the ferrule and all protective parts

## Driveline Assembly

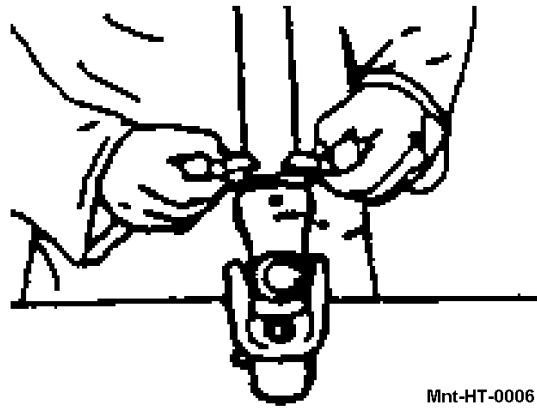

Mnt-HT-0006

Lubricate supporting ferrule seating using Multi-Purpose Gear Oil

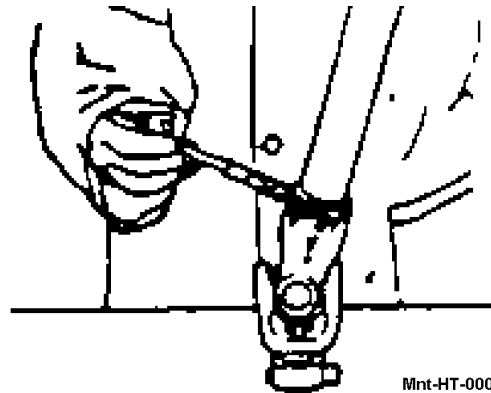

Mnt-HT-0007

# MAINTENANCE

Refit the supporting ferrule.

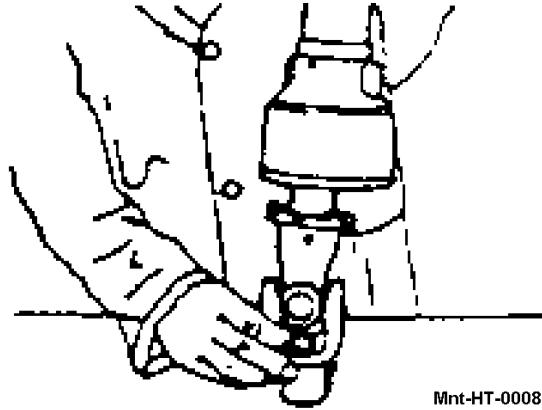

Mnt-HT-0008

Reattach the protective guard to the driveline shaft by turning the eccentric pins on the supporting ferrule.

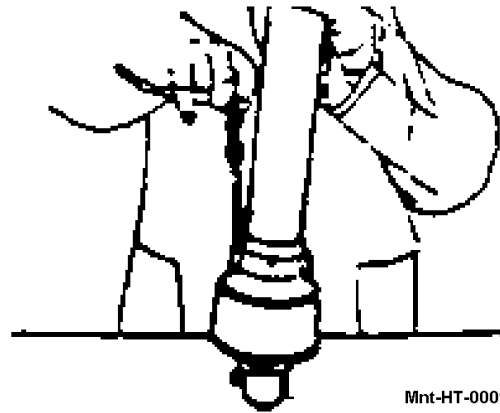

Mnt-HT-0009

MAINTENANCE

# MAINTENANCE

## **STORAGE**

Properly preparing and storing the hay tedder at the end of the season is critical to maintaining its appearance and to help ensure years of dependable service. The following are suggested storage procedures

- Thoroughly clean all debris off the implement to prevent damage from decaying grass.
- Lubricate all grease points and fill gearbox oil levels as detailed in the maintenance section using Multi-Purpose Gear Oil.
- Tighten all bolts and pins to the recommended torque.
- Check worn and damaged parts. Perform repairs and make replacements immediately so that the implement will be ready for use at the start of the next season.
- Store the hay tedder in a clean, dry place with the housing resting securely on blocks or at ground level.
- Use spray touch-up enamel where necessary to prevent rust and maintain the appearance of the hay tedder.
- Store tedder with the wings lowered and the main transport wheels lowered.

## **SCRAPPING THE MACHINE**

The machine consists mainly of ferrous material, a small amount of plastic and a very small amount of residual grease which must be disposed of according to the regulations in force in the country concerned.

## **PROPER TORQUE FOR FASTENERS**

The chart lists the correct tightening torque for fasteners. When bolts are to be tightened or replaced, refer to this chart to determine the grade of bolts and the proper torque except when specific torque values are assigned in manual text.

Recommended Torque in Foot Pounds Unless Otherwise Stated in the Manual\*

**NOTE:** *These values apply to fasteners as received from supplier, dry or when lubricated with normal engine oil. They do not apply if special graphited or molydisulphide greases or other extreme pressure lubricants are used. This applies to both UNF fine and UNC coarse threads.*

# MAINTENANCE

MAINTENANCE

## TORQUE SPECIFICATIONS - DRY TORQUE

Proper torque for American fasteners.  
Recommended Torque in Foot Pounds (Newton Meters).\*

### AMERICAN Bolt Head Markings

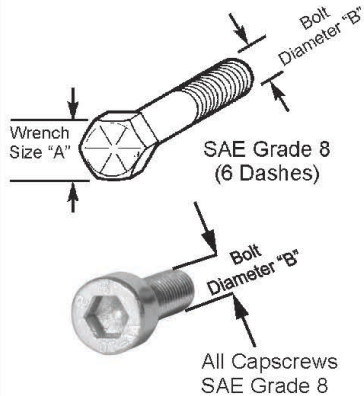

WRENCH SIZE (IN.) "A"	BOLT DIAMETER (IN.) "B" AND THREAD SIZE	SAE GRADE 2	SAE GRADE 5	SAE GRADE 8
7/16	1/4 - 20 UNC	6 (7)	8 (11)	12 (16)
7/16	1/4 - 28 UNF	6 (8)	10 (13)	14 (18)
1/2	5/16 - 18 UNC	11 (15)	17 (23)	25 (33)
1/2	5/16 - 24 UNF	13 (17)	19 (26)	27 (37)
9/16	3/8 - 16 UNC	20 (27)	31 (42)	44 (60)
9/16	3/8 - 24 UNF	23 (31)	35 (47)	49 (66)
5/8	7/16 - 14 UNC	32 (43)	49 (66)	70 (95)
5/8	7/16 - 20 UNF	36 (49)	55 (75)	78 (106)
3/4	1/2 - 13 UNC	49 (66)	76 (103)	106 (144)
3/4	1/2 - 20 UNF	55 (75)	85 (115)	120 (163)
7/8	9/16 - 12 UNC	70 (95)	109 (148)	153 (207)
7/8	9/16 - 18 UNF	79 (107)	122 (165)	172 (233)
15/16	5/8 - 11 UNC	97 (131)	150 (203)	212 (287)
15/16	5/8 - 18 UNF	110 (149)	170 (230)	240 (325)
1-1/8	3/4 - 10 UNC	144 (195)	266 (360)	376 (509)
1-1/8	3/4 - 16 UNF	192 (260)	297 (402)	420 (569)
1-5/16	7/8 - 9 UNC	166 (225)	430 (583)	606 (821)
1-5/16	7/8 - 14 UNF	184 (249)	474 (642)	668 (905)
1-1/2	1 - 8 UNC	250 (339)	644 (873)	909 (1232)
1-1/2	1 - 12 UNF	274 (371)	705 (955)	995 (1348)
1-1/2	1 - 14 UNF	280 (379)	721 (977)	1019 (1381)
1-11/16	1-1/8 - 7 UNC	354 (480)	795 (1077)	1288(1745)
1-11/16	1-1/8 - 12 UNF	397 (538)	890 (1206)	1444 (1957)
1-7/8	1-1/4 - 7 UNC	500 (678)	1120 (1518)	1817 (2462)
1-7/8	1-1/4 - 12 UNF	553 (749)	1241 (1682)	2013 (2728)
2-1/16	1-3/8 - 6 UNC	655 (887)	1470 (1992)	2382 (3228)
2-1/16	1-3/8 - 12 UNF	746 (1011)	1672 (2266)	2712 (3675)
2-1/4	1-1/2 - 6 UNC	870 (1179)	1950 (2642)	3181 (4283)
2-1/4	1-1/2 - 12 UNF	979 (1327)	2194 (2973)	3567 (4820)

### METRIC

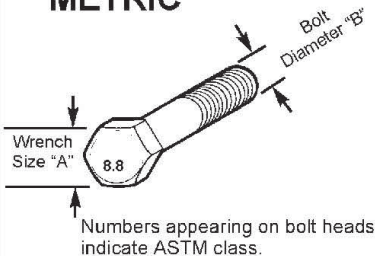

Proper torque for Metric fasteners.  
Recommended torque in Foot Pounds (Newton Meters).\*

WRENCH SIZE (mm) "A"	BOLT DIA. (mm) "B"	ASTM 4.6	ASTM 8.8	ASTM 9.8	ASTM 10.9
8	5	1.8 (2.4)		5.1 (6.9)	6.5 (8.8)
10	6	3 (4)		8.7 (12)	11.1 (15)
13	8	7.3 (10)		21.1 (29)	27 (37)
16	10	14.5 (20)		42 (57)	53 (72)
18	12	25 (34)	74 (100)	73 (99)	93 (126)
21	14	40 (54)	118 (160)	116 (157)	148 (201)
24	16	62 (84)	167 (226)	181 (245)	230 (312)
30	20	122 (165)	325 (440)		449 (608)
33	22		443 (600)		611 (828)
36	24	211 (286)	563 (763)		778 (1054)
41	27		821 (1112)		1138 (1542)
46	30	418 (566)	1119 (1516)		1547 (2096)

\*Use 75% of the specified torque value for plated fasteners. Use 85% of the specified torque values for lubricated fasteners.

Mnt-B-0005





## TO THE OWNER/OPERATOR/DEALER

To keep your implement running efficiently and safely, read your manual thoroughly and follow these directions and the Safety Messages in this Manual. The Table of Contents clearly identifies each section where you can easily find the information you need.

The OCCUPATIONAL SAFETY AND HEALTH ACT (1928.51 Subpart C) makes these minimum safety requirements of tractor operators:

### REQUIRED OF THE OWNER:

1. Provide a Roll-Over-Protective Structure that meets the requirements of this Standard; and
2. Provide Seat belts that meet the requirements of this paragraph of this Standard and SAE J4C; and
3. Ensure that each employee uses such Seat belt while the tractor is moving; and
4. Ensure that each employee tightens the Seat belt sufficiently to confine the employee to the protected area provided by the ROPS

### REQUIRED OF THE OPERATOR:

1. Securely fasten seat belt if the tractor has a ROPS.
2. Where possible, avoid operating the tractor near ditches, embankments, and holes.
3. Reduce speed when turning, crossing slopes, and on rough, slick, or muddy surfaces.
4. Stay off slopes too steep for safe operation.
5. Watch where you are going - especially at row ends, on roads, and around trees.
6. Do not permit others to ride.
7. Operate the tractor smoothly - no jerky turns, starts, or stops.
8. Hitch only to the drawbar and hitch points recommended by the tractor manufacturer.
9. When the tractor is stopped, set brakes securely and use park lock, if available.

**X** Keep children away from danger all day, every day...

**X** Equip tractors with rollover protection (ROPS) and keep all machinery guards in place...

**X** Please work, drive, play and live each day with care and concern for your safety and that of your family and fellow citizens.



**BUSH HOG<sup>®</sup>**

**HT417/ HT417H  
HAY TEDDER**