



# BUSH HOG®

PHDHF15, PHDHF20, PHDHF30,  
PHDHF15-2, PHDHF20-2, PHDHF30-2,  
PHDHF35, PHDHC20,  
PHDHC30, PHDHC35

HYDRAULIC  
PLANETARY DRIVE DIGGER

Published 03/24

Part No.50074550

## OPERATOR'S MANUAL



This Operator's Manual is an integral part of the safe operation of this machine and must be maintained with the unit at all times. **READ, UNDERSTAND, and FOLLOW** the Safety and Operation Instructions contained in this manual before operating the equipment. *C01-Cover str*

### PHDHF SERIES



FC-C-0003

### PHDHF-2 SERIES



FC-D-0005

### PHDHC SERIES



FC-D-0004

**BUSH HOG®**

2501 Griffin Ave.  
Selma, AL 36703  
334-874-2700  
www.bushhog.com

Bush Hog Web Page



www.alqr.com/bwe

**¡ATENCIÓN!**  
LEA EL INSTRUCTIVO



Si No Lee Ingles, Pida  
Ayuda a Alguien  
Que Se Lo Lea Para Que Ie  
Traduzca Las  
Medidas de Seguridad

**MEMBER OF THE  
ALAMO GROUP**

ALWAYS ON THE CUTTING EDGE®

## To the Owner/Operator/Dealer

All implements with moving parts are potentially hazardous. There is no substitute for a cautious, safe-minded operator who recognizes the potential hazards and follows reasonable safety practices. The manufacturer has designed this implement to be used with all its safety equipment properly attached to minimize the chance of accidents.

**BEFORE YOU START!** Read the safety messages on the implement and shown in your manual. Observe the rules of safety and common sense!

<b>! DANGER</b>	
 00767037	<b>ENTANGLEMENT HAZARD</b>  <b>To Prevent Death or Serious Injury: KEEP AT LEAST 25 FEET AWAY</b> <ul style="list-style-type: none"><li>• Do not operate unless all Guards are in place.</li><li>• Do not use body weight to force auger into ground or position Auger Point when engine is running.</li><li>• Make certain auger point is right for your job and that the Lead Screw and Bits are in good condition.</li><li>• See Manual for optional Points and for advice on digging in very hard, rocky, and sticky conditions.</li><li>• Keep away from rotating auger and driveline.</li></ul>

### WARRANTY INFORMATION:

Read and understand the complete Warranty Statement found in this Manual. Fill out the Warranty Registration Form in full and return it to within 30 Days. Make certain the Serial Number of the Machine is recorded on the Warranty Card and on the Warranty Form that you retain.

# Table of Contents

<b>SAFETY SECTION</b> .....	<b>1 - 1</b>
GENERAL SAFETY INSTRUCTIONS AND PRACTICES .....	1 - 2
OPERATOR SAFETY INSTRUCTIONS AND PRACTICES .....	1 - 3
EQUIPMENT OPERATION SAFETY INSTRUCTIONS AND PRACTICES .....	1 - 5
CONNECTING OR DISCONNECTING SAFETY INSTRUCTIONS AND PRACTICES .....	1 - 7
TRANSPORTING SAFETY INSTRUCTIONS AND PRACTICES .....	1 - 7
MAINTENANCE AND SAFETY INSTRUCTIONS & PRACTICES .....	1 - 8
PARTS INFORMATION .....	1 - 10
STORAGE AND PARKING SAFETY INSTRUCTIONS AND PRACTICES.....	1 - 10
CONCLUDING SAFETY INSTRUCTIONS AND PRACTICES.....	1 - 10
DECAL LOCATION - PHDHF SERIES .....	1 - 11
DECAL LOCATION - PHDHC SERIES .....	1 - 12
DECAL LOCATION - PHDHF-2 AND PHDF35 SERIES .....	1 - 13
DECAL LOCATION - PHDHF, PHDHF-2, PHDHF35, PHDHC Skid Steer Mounts .....	1 - 14
DECAL DESCRIPTION .....	1 - 15
FEDERAL LAWS AND REGULATIONS .....	1 - 17
<b>INTRODUCTION SECTION</b> .....	<b>2 - 1</b>
ATTENTION OWNER/OPERATOR .....	2 - 4
LIMITED WARRANTY for PHDHC Models.....	2 - 5
LIMITED WARRANTY for PHDHF Models .....	2 - 6
LIMITED WARRANTY for PHDHF-2 & PHDHF35 Models .....	2 - 7
<b>ASSEMBLY SECTION</b> .....	<b>3 - 1</b>
LOADER BUCKET HITCH MOUNT ASSEMBLY (PHDHF & PHDHC) .....	3 - 2
SKID STEER HITCH ASSEMBLY (PHDHF & PHDHC) .....	3 - 2
LOADER BUCKET HITCH MOUNT ASSEMBLY (PHDHF-2 & PHDHF35) .....	3 - 3
SKID STEER HITCH ASSEMBLY (PHDHF-2 & PHDHF35).....	3 - 3
ATTACHING AUGER TO GEARBOX OUTPUT SHAFT .....	3 - 4
<b>OPERATION SECTION</b> .....	<b>4 - 1</b>
STANDARD EQUIPMENT AND SPECIFICATIONS .....	4 - 3
OPERATOR REQUIREMENTS .....	4 - 5
POWER UNIT REQUIREMENTS .....	4 - 6
ROPS and Seat Belt.....	4 - 6
Power Unit Safety Devices .....	4 - 7
Auxiliary Hydraulics .....	4 - 7
GETTING ON AND OFF THE POWER UNIT .....	4 - 8
Boarding the Power Unit.....	4 - 8
Dismounting the Power Unit .....	4 - 8
STARTING THE POWER UNIT .....	4 - 9
PRE-OPERATION INSPECTION AND SERVICE .....	4 - 10
Power Unit Pre-Operation Inspection/Service .....	4 - 10
Digger Pre-Operation Inspection/Service .....	4 - 11
HYDRAULIC POST HOLE DIGGER PRE-OPERATION INSPECTION .....	4 - 12

# Table of Contents

OPERATING THE POWER UNIT AND IMPLEMENT .....	4 - 13
Digger Operating Instructions .....	4 - 14
Auger Selection Based On Drilling Application .....	4 - 15
IMPLEMENT STORAGE .....	4 - 16
TRANSPORTING THE POWER UNIT AND IMPLEMENT .....	4 - 16
Transporting on Public Roadways .....	4 - 17
Hauling the Power Unit and Implement .....	4 - 18
TROUBLESHOOTING GUIDE .....	4 - 20
<b>MAINTENANCE SECTION .....</b>	<b>5 - 1</b>
AUGER MAINTENANCE .....	5 - 3
MACHINE INSPECTION .....	5 - 3
STORAGE .....	5 - 3
HYDRAULIC LINES, COUPLERS & ADAPTERS .....	5 - 4
PROPER TORQUE FOR FASTENERS .....	5 - 4

# **SAFETY SECTION**

Safety Section 1-1

# SAFETY

## GENERAL SAFETY INSTRUCTIONS AND PRACTICES

A careful operator is the best operator. Safety is of primary importance to the manufacturer and should be to the owner/operator. Most accidents can be avoided by being aware of your equipment, your surroundings, and observing certain precautions. The first section of this manual includes a list of Safety Messages that, if followed, will help protect the operator and bystanders from injury or death. Read and understand these Safety Messages before assembling, operating or servicing this Implement. This equipment should only be operated by those persons who have read the manual, who are responsible and trained, and who know how to do so responsibly.



The Safety Alert Symbol combined with a Signal Word, as seen below, is used throughout this manual and on decals which are attached to the equipment. The Safety Alert Symbol means: "ATTENTION! BECOME ALERT! YOUR SAFETY IS INVOLVED!" The Symbol and Signal Word are intended to warn the owner/operator of impending hazards and the degree of possible injury faced when operating this equipment.

**Practice all usual and customary safe working precautions and above all--remember safety is up to YOU. Only YOU can prevent serious injury or death from unsafe practices.**



Indicates an imminently hazardous situation that, if not avoided, WILL result in DEATH OR VERY SERIOUS INJURY.



Indicates an imminently hazardous situation that, if not avoided, COULD result in DEATH OR SERIOUS INJURY.



Indicates an imminently hazardous situation that, if not avoided, MAY result in MINOR INJURY.



Identifies special instructions or procedures that, if not strictly observed, could result in damage to, or destruction of the machine, attachments or the environment.

**NOTE:** *Identifies points of particular interest for more efficient and convenient operation or repair.* (SG-1) str

READ, UNDERSTAND, and FOLLOW the following Safety Messages. Death or serious injury may occur unless care is taken to follow the warnings and instructions stated in the Safety Messages. Always use good common sense to avoid hazards. (SG-2) str



Si no lee ingles, pida ayuda a alguien que si lo lea para que le traduzca las medidas de seguridad. (SG-3) str

**¡ LEA EL INSTRUCTIVO!**



# SAFETY

SAFETY

## OPERATOR SAFETY INSTRUCTIONS AND PRACTICES



Never crawl under a raised Implement supported solely by the Power Unit boom. Release of the control lever or mechanical failure will result in the Implement falling and possible injury or death. Always securely block up the Implement before crawling underneath to perform repairs and service. (SPU-33) str



Never operate the Power Unit or Implement until you have read and completely understand this Manual, the Power Unit Operator's Manual, and each of the Safety Messages found in the Manual or on the Power Unit and Implement. Learn how to stop the Power Unit engine suddenly in an emergency. Never allow inexperienced or untrained personnel to operate the Power Unit and Implement without supervision. Make sure the operator has fully read and understood the manuals prior to operation. (SPU-36) str



Always maintain the safety signs in good readable condition. If the safety signs are missing, damaged, or unreadable, obtain and install replacement safety signs immediately. (SG-5)str



The operator and all support personnel should wear hard hats, safety shoes, safety glasses, and proper hearing protection at all times for protection from injury including injury from items that may be thrown by the equipment. (SG-16)str

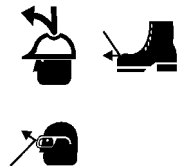

PROLONGED EXPOSURE TO LOUD NOISE MAY CAUSE PERMANENT HEARING LOSS! Tractors with or without an Implement attached can often be noisy enough to cause permanent hearing loss. We recommend that you always wear hearing protection if the noise in the Operator's position exceeds 80db. Noise over 85db over an extended period of time will cause severe hearing loss. Noise over 90db adjacent to the Operator over an extended period of time will cause permanent or total hearing loss.

**NOTE:** Hearing loss from loud noise [from tractors, chain saws, radios, and other such sources close to the ear] is cumulative over a lifetime without hope of natural recovery. (SG-17)str



Always read carefully and comply fully with the manufacturer's instructions when handling oil, solvents, cleansers, and any other chemical agent. (SG-22)str



Never run the Power Unit engine in a closed building or without adequate ventilation. The exhaust fumes can be hazardous to your health. (SPU-23) str

# SAFETY



**DANGER**

KEEP AWAY FROM ROTATING ELEMENTS to prevent entanglement and possible serious injury or death. (SPHD-2) str



**DANGER**

**NEVER** put hands on the Post Hole Digger Auger, Gearbox, or Boom to locate the Auger when there is any sign of rotation of the Driveline or Auger. Post Hole Diggers are operated by one person from the tractor seat. Keep all bystanders and/or coworkers away from the Post Hole Digger. (SPHD-4) str



**DANGER**

Never use body weight to try to push Auger into the ground to prevent entanglement and possible serious injury or death. (See Operating Instructions for advice on drilling in hard ground or rocky conditions.) (SPHD-8) str



**DANGER**

There are obvious and hidden potential hazards in the operation of this Post Hole Digger. **REMEMBER!** This machine can be operated on hillsides and slopes and in other rough conditions which require increased care and increased awareness of the potential hazards on both the operator's and any bystander's part. Serious injury or even death may occur unless care is taken to insure the safety of the operator, helpers, and any bystanders. (SPHD-11) str



**DANGER**

Always keep a careful lookout and use extreme care when working around overhead obstructions. Never allow the Auger within 10 feet of any power line. When working close to overhead power lines exercise caution and consult your electric company for a safe code of operation. (SPHD-13) str



**DANGER**

Dig holes only while seated in the Operator's seat with the seatbelt securely fastened. Keep all other persons a minimum distance of 10 feet away from the Tractor and Digger. Always engage the Tractor parking brakes and set the transmission in park when operating the digger. (SPHD-14) str



**DANGER**

Never allow children to play on or around Power Unit or Implement. Children can slip or fall off the Equipment and be injured or killed. Children can cause the Implement to shift or fall crushing themselves or others. (SPU-24) str



# SAFETY

## **⚠ DANGER**

**NEVER use drugs or alcohol** immediately before or while operating the Power Unit and Implement. Drugs and alcohol will affect an operator's alertness and coordination and therefore affect the operator's ability to operate the equipment safely. Before operating the Power Unit or Implement, an operator on prescription or over-the-counter medication must consult a medical professional regarding any side effects of the medication that would hinder their ability to operate the Equipment safely. **NEVER** knowingly allow anyone to operate this equipment when their alertness or coordination is impaired. Serious injury or death to the operator or others could result if the operator is under the influence of drugs or alcohol. (SPU-25) str



## **⚠ WARNING**

Prolonged operation may cause operator boredom and fatigue affecting safe operation. Take scheduled work breaks to help prevent these potentially impaired operating conditions. Never operate the Implement and Tractor in a fatigued or bored mental state which impairs proper and safe operation. (SG-32) str

## **⚠ WARNING**

Use extreme caution when getting onto the Implement to perform repairs, maintenance and when removing accumulated material. Only stand on solid flat surfaces to ensure good footing. Use a ladder or raised stand to access high spots which cannot be reached from ground level. Slipping and falling can cause serious injury or death.

(SG-33) str

## **⚠ WARNING**

Avoid contact with hot surfaces including hydraulic oil tanks, pumps, motors, valves and hose connections. Relieve hydraulic pressure before performing maintenance or repairs. Use gloves and eye protection when servicing hot components. Contact with a hot surface or fluid can cause serious injury from burns or scalding. (SG-34str)

## **⚠ WARNING**

Avoid contact with hot surfaces of the engine or muffler. Use gloves and eye protection when servicing hot components. Contact with a hot surface or fluid can cause serious injury from burns or scalding. (SG-38) str

## **⚠ DANGER**

Do not operate the implement while wearing loose fitting clothing. Entanglement of the clothing with the rotating elements can result in serious injury or even death. Stay clear of all rotating elements at all times. (SSP-03)str

**SAFETY**

## **EQUIPMENT OPERATION SAFETY INSTRUCTIONS AND PRACTICES**

## **⚠ WARNING**

Never leave the Tractor and Implement unattended while the Implement is in the lifted position. Accidental operation of lifting lever or a hydraulic failure may cause sudden drop of unit with injury or death by crushing. To properly park the implement when disconnecting it from the tractor, lower the stand and put the retaining pin securely in place, or put a secure support under the A-Frame. Lower the implement carefully to the ground. Do not put hands or feet under lifted components. (S3PT-01) str

## **⚠ WARNING**

Be sure you have adequate knowledge of the property you will be working on. Take time to make yourself aware of any area underwater or underground lines or cables. Contact with buried lines or cable could result in serious injury or death. (STL-1) str

# SAFETY

**WARNING**

Operate this Equipment only with a Power Unit equipped with an approved operator Roll-Over Protective Structure (ROPS). Always wear seat belts. Serious injury or even death could result from falling off the Power Unit--particularly during a turnover when the operator could be pinned under the Operator Protective Structure. (SPU-14) str



**DANGER**

BEFORE leaving the Power Unit seat, always engage the brake and set the Power Unit transmission in parking gear, disengage the auxiliary hydraulics, stop the engine, remove the key, and wait for all moving parts to stop. Place the Power Unit shift lever into a low range or parking gear to prevent the tractor from rolling. Never dismount a Power Unit that is moving or while the engine is running. Operate the Power Unit controls from the operator seat only. (SPU-15) str

**DANGER**

Never allow children to operate or ride on the Power Unit or Implement. (SPU-17) str



**DANGER**

Never allow children to operate, ride on, or come close to the Tractor or Implement. Usually, 16-17 year-old children who are mature and responsible can operate the implement with adult supervision, if they have read and understand the Operator's Manuals, been trained in proper operation of the tractor and Implement, and are physically large enough to reach and operate the controls easily. (SG-11) str



**DANGER**

Do not mount the Power Unit while the Power Unit is moving. Mount the Power Unit only when the Power Unit and all moving parts are completely stopped. (SPU-18) str



**DANGER**

Start the Power Unit only when properly seated in the Power Unit seat. Starting a Power Unit in gear can result in injury or death. Read the Power Unit Operator's Manual for proper starting instructions. (SPU-19) str



# SAFETY

## **WARNING**

Do not operate this Equipment with hydraulic oil or fuel leaking. Oil and fuel are explosive and their presence could present a hazard. Do not check for leaks with your hand! High-pressure oil streams from breaks in the line could penetrate the skin and cause tissue damage including gangrene. To check for a hose leak, SHUT the unit ENGINE OFF and remove all hydraulic pressure. Wear oil impenetrable gloves, safety glasses and use cardboard to check for evidence of oil leaks. If you suspect a leak, REMOVE the HOSE and have it tested at a Dealer. If oil does penetrate the skin, have the injury treated immediately by a physician knowledgeable and skilled in this procedure. (SG-15) str



## **DANGER**

Operate the Power Unit and/or Implement controls only while properly seated in the Power Unit seat with the seat belt securely fastened around you. Inadvertent movement of the Power Unit or Implement may cause serious injury or death. (SPU-26) str

## **WARNING**

Do Not operate this equipment in areas where insects such as bees, may attack you and/or cause you to lose control of the equipment. If you must enter into such areas, use a tractor with an enclosed Cab and close the windows to prevent insects from entering. If a tractor cab is not available, wear suitable clothing including head, face, and hand protection to shield you from insects. Attacking insects can cause you to lose control of the tractor, which can result in serious injury or death to you or bystanders. Never dismount a moving tractor. (SG-40) str

## **WARNING**

Extreme care should be taken when operating near loose objects such as gravel, rocks, wire, and other debris. Inspect the area before mowing. Foreign objects should be removed from the site to prevent machine damage and/or bodily injury or even death. Any objects that cannot be removed must be clearly marked and carefully avoided by the operator. Stop mowing immediately if blades strike a foreign object. Repair all damage and make certain rotor or blade carrier is balanced before resuming mowing. (SGM-05)str



SAFETY

## **CONNECTING OR DISCONNECTING SAFETY INSTRUCTIONS AND PRACTICES**

### **DANGER**

Always shut the Power Unit completely down, place the transmission in park, and set the parking brake before you or anyone else attempts to connect or disconnect the Implement and Power Unit hitches. (SPU-32) str

## **TRANSPORTING SAFETY INSTRUCTIONS AND PRACTICES**

### **WARNING**

Make certain that the "Slow Moving Vehicle" (SMV) sign is installed in such a way as to be clearly visible and legible. When transporting the Equipment use the Tractor flashing warning lights and follow all local traffic regulations. (SG-6)str

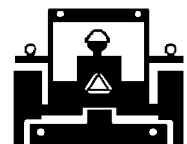

# SAFETY

## **WARNING**

Use extreme care when the Auger is in the transport position to prevent contact between the Auger and bystanders or solid objects. Contact with the Auger could cause serious damage, injury, or death. Never operate the Auger while in the transport position. (SPHD-12) str

## **DANGER**

Transport only at safe speeds. Serious accidents and injuries can result from operating this equipment at unsafe speeds. Understand the Power Unit and Implement and how it handles before transporting on streets and highways. Make sure the Power Unit steering and brakes are in good condition and operate properly.



Before transporting the Power Unit and Implement, determine the safe transport speeds for you and the equipment. Make sure you abide by the following rules:

- Test the Power Unit at a slow speed and increase the speed slowly. Apply the Brakes smoothly to determine the stopping characteristics of the Power Unit and Implement. As you increase the speed of the Power Unit the stopping distance increases. Determine the maximum safe transport speed for you and this Equipment.
- Test the equipment at a slow speed in turns. Increase the speed through the turn only after you determine that it is safe to operate at a higher speed. Use extreme care and reduce your speed when turning sharply to prevent the tractor and implement from turning over. Determine the maximum safe turning speed for you and this equipment before operating on roads or uneven ground.
- Only transport the Power Unit and Implement at the speeds that you have determined are safe and which allow you to properly control the equipment.

Be aware of the operating conditions. Do not operate the Power Unit with weak or faulty brakes. When operating down a hill or on wet or rain slick roads, the braking distance increases: use extreme care and reduce your speed. When operating in traffic always use the Power Unit's flashing warning lights and reduce your speed. Be aware of traffic around you and watch out for the other guy. (SPU-21) str



## **WARNING**

Your driving vision may be reduced or impaired by the tractor, cab, or implement. Before driving on public roadways identify any limited vision areas, and make adjustments to your operating position, mirrors, and the implement transport position so that you can clearly see the area where you will be traveling, and any traffic that may approach you. Failure to maintain adequate vision of the public roadway and traffic can result in serious injury or even death.

(STI-10)

## **MAINTENANCE AND SAFETY INSTRUCTIONS & PRACTICES**

## **DANGER**

Always disconnect the auxiliary hydraulic couplers from the Power Unit before performing service on the Implement. Never work on the Implement with the Power Unit auxiliary hydraulics connected. Rotating parts could turn without warning and cause immediate entanglement, injury or death. (SPU-31) str

## **WARNING**

Never interfere with factory-set hydraulic calibrations. Any change in calibration could cause a failure of the equipment and may result in injury. (SBH-13)str

# SAFETY



**WARNING**

Always maintain the safety signs in good readable condition. If the safety signs are missing, damaged, or unreadable, obtain and install replacement safety signs immediately. (SG-5)str



**WARNING**

Do not modify or alter this Implement. Do not permit anyone to modify or alter this Implement, any of its components or any Implement function. (SG-8)str



**DANGER**

Never work under the Implement, the framework, or any lifted component unless the Implement is securely supported or blocked up to prevent sudden or inadvertent falling which could cause death or serious injury. (SG-14)str



**WARNING**

Never attempt to lubricate, adjust, or remove material from the Implement while it is in motion or while tractor engine is running. (SG-20)str



**WARNING**

Periodically inspect all moving parts for wear and replace when necessary with authorized service parts. Look for loose fasteners, worn or broken parts, and leaky or loose fittings. Make sure all pins have cotter pins and washers. Serious injury may occur from not maintaining this machine in good working order. (SG-21)str

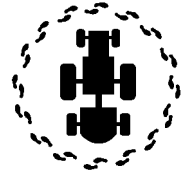

**WARNING**

Perform service, repairs and lubrication according to the maintenance section. Ensure the unit is properly lubricated as specified in the lubrication schedule and all bolts and nuts are properly torqued. Failure to properly service, repair and maintain this Implement in good operating condition could cause component failure and possible serious injury or even death. (SG-35)str



**WARNING**

Use caution and wear protective gloves when handling sharp objects such as blades, knives, and other cutting edges. Be alert to worn component surfaces which have sharp edges. Sharp surfaces can inflict severe laceration injuries if proper hand protection is not worn. (SG-37)str



**DANGER**

Never run the Tractor engine in a closed building or without adequate ventilation. The exhaust fumes can be hazardous to your health. (SG-23)str



**WARNING**

Cancer and Reproductive Harm [www.P65Warnings.ca.gov](http://www.P65Warnings.ca.gov)

SAFETY

# SAFETY

## PARTS INFORMATION

Bush Hog products are designed utilizing specifically matched system components to ensure optimum equipment performance. These parts are made and tested to Bush Hog specifications. Non-genuine "will fit" parts do not consistently meet these specifications. The use of "will fit" parts may reduce equipment performance, void warranties, and present a safety hazard. Use genuine Bush Hog parts for economy and safety. (SPBH-2)str

## SEE YOUR BUSH HOG DEALER

Operator's & Parts Manuals



[www.algqr.com/bpm](http://www.algqr.com/bpm)



Be sure you have adequate knowledge of the property you will be working on. Take time to make yourself aware of any area underwater or underground lines or cables. Contact with buried lines or cable could result in serious injury or death. (STL-1) str



In wet conditions where there is a likelihood of material collecting on the Implement, make certain that this material is removed before traveling on public roadways. (STL-7) str

## STORAGE AND PARKING SAFETY INSTRUCTIONS AND PRACTICES



To prevent tipping of Implement when stored in folded position, use carrying wheels or adequate stands on center frame. (S3PT-6) str

## CONCLUDING SAFETY INSTRUCTIONS AND PRACTICES

In addition to the design and configuration of this Implement, including Safety Signs and Safety Equipment, hazard control and accident prevention are dependent upon the awareness, concern, prudence, and proper training of personnel involved in the operation, transport, maintenance, and storage of the machine. Refer also to Safety Messages and operation instruction in each of the appropriate sections of the Tractor and Equipment Manuals. Pay close attention to the Safety Signs affixed to the Tractor and Equipment. (SG-18)str

# SAFETY

SAFETY

## DECAL LOCATION - PHDHF SERIES

**NOTE:** Bush Hog supplies safety decals on this product to promote safe operation. Damage to the decals may occur while in shipping, use, or reconditioning. Bush Hog cares about the safety of its customers, operators, and bystanders, and will replace the safety decals on this product in the field, free of charge (Some shipping and handling charges may apply). Contact your Bush Hog dealer to order replacement decals.

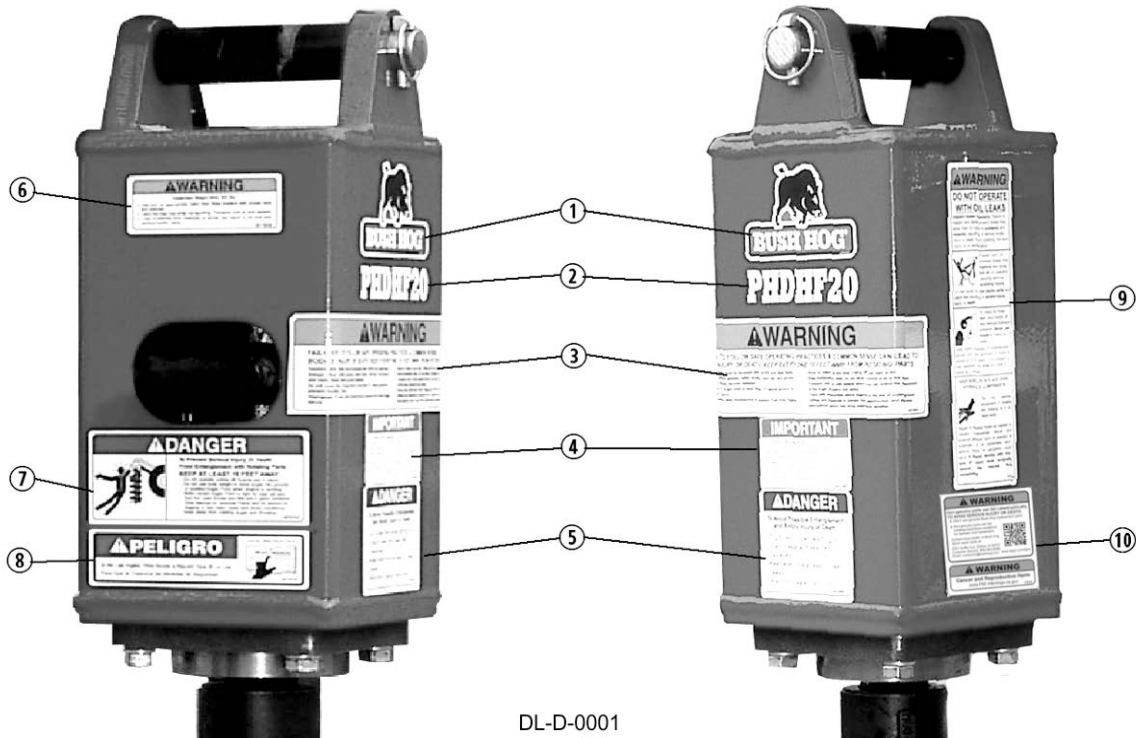

DL-D-0001

ITEM	PART NO.	QTY	TYPE	DESCRIPTION
	50074547	1	DECAL SHEET	Sheet of Decals (Items 1 & 3-10)
1.	50074570	1	LOGO	Bush Hog Decal
2.	50074538	1	MODEL NAME	PHDHF15 Model
	50074539	1	MODEL NAME	PHDHF20 Model
	50074540	1	MODEL NAME	PHDHF30 Model
3.	00776401	1	WARNING	Multi-Hazard
4.	50074569	1	IMPORTANT	Important
5.	00776400	1	DANGER	Dig from Tractor Seat
6.	00778038	1	WARNING	Implement Weight
7.	00767037	1	DANGER	Entanglement Hazard
8.	00725746	1	PELIGRO	Get Manual Translated
9.	52740	1	WARNING	Oil Leak
10.	D859	1	WARNING	Use Genuine Bush Hog Parts

Item #2 **MUST** be ordered separately. Not included on Decal Sheet.

# SAFETY

## DECAL LOCATION - PHDHC SERIES

**NOTE:** Bush Hog supplies safety decals on this product to promote safe operation. Damage to the decals may occur while in shipping, use, or reconditioning. Bush Hog cares about the safety of its customers, operators, and bystanders, and will replace the safety decals on this product in the field, free of charge (Some shipping and handling charges may apply). Contact your Bush Hog dealer to order replacement decals.

**SAFETY**



DL-D-0002

ITEM	PART NO.	QTY	TYPE	DESCRIPTION
	50074547	1	DECAL SHEET	Sheet of Decals (Items 1 & 3-10)
1.	50074570	1	LOGO	Bush Hog Decal
2.	50074557	1	MODEL NAME	PHDHC20 Model
	50074558	1	MODEL NAME	PHDHC30 Model
	50074559	1	MODEL NAME	PHDHC35 Model
3.	00776401	1	WARNING	Multi-Hazard
4.	50074569	1	IMPORTANT	Important
5.	00767037	1	DANGER	Entanglement Hazard
6.	00776400	1	DANGER	Dig from Tractor Seat
7.	00725746	1	PELIGRO	Get Manual Translated
8.	00778038	1	WARNING	Implement Weight
9.	52740	1	WARNING	Oil Leak
10.	D859	1	WARNING	Use Genuine Bush Hog Parts

*Item #2 MUST be ordered separately. Not included on Decal Sheet.*



# SAFETY

## DECAL LOCATION - PHDHF-2 AND PHDF35 SERIES

*NOTE: Bush Hog supplies safety decals on this product to promote safe operation. Damage to the decals may occur while in shipping, use, or reconditioning. Bush Hog cares about the safety of its customers, operators, and bystanders, and will replace the safety decals on this product in the field, free of charge (Some shipping and handling charges may apply). Contact your Bush Hog dealer to order replacement decals.*



DL-D-0005

ITEM	PART NO.	QTY	TYPE	DESCRIPTION
	50074547	1	DECAL SHEET	Sheet of Decals (Items 1 & 3-10)
1.	50074570	1	LOGO	Bush Hog Decal
2.	50074538	1	MODEL NAME	PHDHF15 Model
	50074539	1	MODEL NAME	PHDHF20 Model
	50074540	1	MODEL NAME	PHDHF30 Model
	50077008	1	MODEL NAME	PHDHF35 Model
3.	00776401	1	WARNING	Multi-Hazard
4.	50074569	1	IMPORTANT	Important
5.	00776400	1	DANGER	Dig from Tractor Seat
6.	00778038	1	WARNING	Implement Weight
7.	00767037	1	DANGER	Entanglement Hazard
8.	00725746	1	PELIGRO	Get Manual Translated
9.	52740	1	WARNING	Oil Leak
10.	D859	1	WARNING	Use Genuine Bush Hog Parts

*Item #2 MUST be ordered separately. Not included on Decal Sheet.*

# SAFETY

## **DECAL LOCATION - PHDHF, PHDHF-2, PHDHF35, PHDHC SKID STEER MOUNTS**

*NOTE: Bush Hog supplies safety decals on this product to promote safe operation. Damage to the decals may occur while in shipping, use, or reconditioning. Bush Hog cares about the safety of its customers, operators, and bystanders, and will replace the safety decals on this product in the field, free of charge (Some shipping and handling charges may apply). Contact your Bush Hog dealer to order replacement decals.*

**SAFETY**

DL-D-0003

Skid Steer Mount

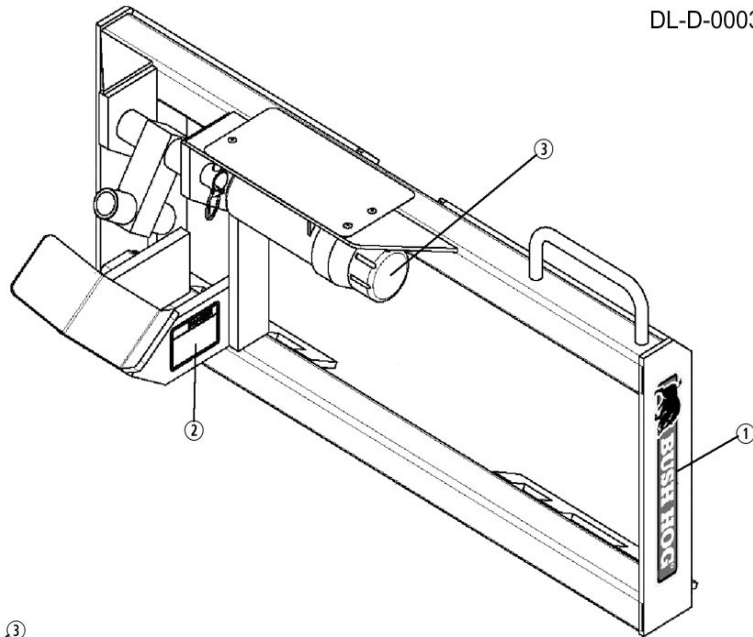

Skid Steer Mount

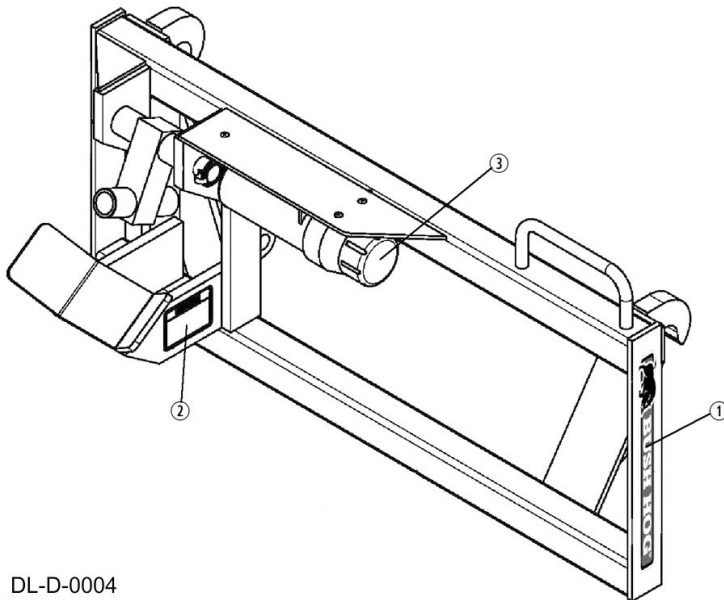

DL-D-0004

ITEM	PART NO.	QTY	TYPE	DESCRIPTION
1.	50065309	2	LOGO	Bush Hog
2.	50074568	2	DANGER	Read Manual - Follow Directions
3.	50035829	1	---	Canister, Operator's Manual

# SAFETY

SAFETY

## DECAL DESCRIPTION

### ⚠ WARNING

#### OPERATION HAZARDS

**FAILURE TO FOLLOW SAFE OPERATING PRACTICES AND COMMON SENSE CAN CAUSE DEATH OR SERIOUS INJURY. KEEP EVERYONE 25 FEET AWAY FROM ROTATING PARTS.**

- Tractor must be equipped with ROPS, Seat Belts, and Stabilizers.
- Always wear safety glasses, safety shoes, hard hat, and gloves and have Seat Belts securely fastened. Adjust Stabilizers snugly.
- Make certain that Auger and Driveline Shields are installed properly. If either is missing, do not operate until all are re-installed properly.
- Do not operate PTO if Auger Point is more than 12" above ground to prevent Driveline failure which could cause death or serious injury.
- Disengage PTO when transporting to prevent Driveline failure.
- Allow no riders at any time. Falling can cause death or serious injury.
- Keep bystanders clear. Do not allow children to be in the area.
- Do not exceed 300 RPM PTO speed maximum (Half Throttle).
- Check with authorities before digging in the area of underground utilities and pipelines to prevent fire, electrocution, and service interruptions which may bring expensive penalties.

00776401

### ⚠ DANGER

#### ENTANGLEMENT HAZARD

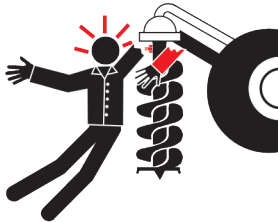

**To Prevent Death or Serious Injury:  
KEEP AT LEAST 25 FEET AWAY**

- Do not operate unless all Guards are in place.
- Do not use body weight to force auger into ground or position Auger Point when engine is running.
- Make certain auger point is right for your job and that the Lead Screw and Bits are in good condition.
- See Manual for optional Points and for advice on digging in very hard, rocky, and sticky conditions.
- Keep away from rotating auger and driveline.

00767037

### ⚠ PELIGRO

#### LEA EL INSTRUCTIVO

Si No Lee Ingles, Pida Ayuda a Alguien Que Si Lo Lea Para Que le Traduzca las Medidas de Seguridad.



00725746

## IMPORTANT

An **OPERATOR'S MANUAL** was attached to this implement during assembly. If Manual was not attached at time of purchase, please contact your selling dealer at once or visit the BUSH HOG website at: [www.bushhog.com](http://www.bushhog.com)

1. Read and understand the Operator's Manual before Operating this Implement.
2. Make sure your dealer has registered your Warranty on line with Bush Hog at time of purchase.

50074569

### ⚠ DANGER

#### TO PREVENT SERIOUS INJURY OR DEATH:

*Si no entiende ingles, se pretiere que busque a alguien que interprete las instrucciones para usted.*

- Read and understand owner's manual before operating.
- Operate only from the tractor seat.
- Stay away from rotating parts. Keep others away.
- Do not dig around underground utility lines without checking with authorities.

50074568

# SAFETY

SAFETY

## ⚠️ WARNING

### DO NOT OPERATE WITH OIL LEAKS

Inspect hoses regularly. Failure to inspect and replace worn hoses may allow them to rupture suddenly and violently resulting in death or serious bodily injury from scalding, fire burn injury or oil penetration.



Frayed, torn, or crimped hoses may rupture and spray hot oil on operator causing serious scalding injury.

Oil may spray on hot tractor parts and catch fire resulting in death, severe injury or burns.



To check for hose leak, shut tractor off and remove hydraulic pressure. Never use hands to check for leaks.

Wear safety glasses with side shields (marked to comply with ANSI Z87), oil impenetrable gloves, and use cardboard to check for evidence of oil leaks. If you suspect a leak, remove the hose and have it tested at a dealer.

### KEEP SHIELDS IN PLACE OVER HYDRAULIC COMPONENTS



Do not operate equipment if shields are missing or if oil leaks exist.

Repair or replace hoses as needed to prevent unexpected failure and possible serious injury to operator or bystander. If oil penetrates skin, serious injury or gangrene could occur. A doctor familiar with this type of injury must surgically remove the injected fluid immediately.

52740

## ⚠️ WARNING

### TO AVOID DEATH OR SERIOUS INJURY:

- ONLY use genuine Bush Hog replacement parts, which have been validated and tested to use on Bush Hog equipment by the manufacturer.
- The equipment manufacturer cannot verify the material or structural integrity of third-party supplied non-genuine replacement parts.
- Using non-genuine parts can result in the part failing, creating hazardous conditions for operator and bystanders.

Contact local dealer or Bush Hog about repair parts at:

2501 Griffin Ave., Selma, AL 36701  
Customer Service: 800-363-6096.  
Email: [contactus@bushhog.com](mailto:contactus@bushhog.com)



[www.algqr.com/bpm](http://www.algqr.com/bpm)

## ⚠️ WARNING

### Cancer and Reproductive Harm

[www.P65Warnings.ca.gov](http://www.P65Warnings.ca.gov)

D859

## ⚠️ DANGER

### ENTANGLEMENT HAZARD

To Avoid Death or Serious Injury:

- Dig holes only while sitting on tractor seat with seatbelt fastened.
- Keep everyone at least 25 feet away.
- Atencion: Lea el Instructivo.

00776400

## ⚠️ WARNING

### ROLL OVER HAZARD

Max. implement weight 800 lbs. To avoid death or serious injury:

- Use appropriate Skid Steer loader with correct hitch and adapter.
- Carry load low when transporting and transport at slow speed.
- Overload or terrain can cause loss of stability and roll over.

00778038

# SAFETY

## FEDERAL LAWS AND REGULATIONS

This section is intended to explain in broad terms the concept and effect of federal laws and regulations concerning employer and employee equipment operators. This section is not intended as a legal interpretation of the law and should not be considered as such.

### **Employer-Employee Operator Regulations**

U.S. Public Law 91-596 (The Williams-Steiger Occupational and Health Act of 1970) OSHA

#### **This Act Seeks:**

“...to assure so far as possible every working man and woman in the nation safe and healthful working conditions and to preserve our human resources...”

#### **DUTIES**

Sec. 5 (a) Each employer-

(1) shall furnish to each of his employees employment and a place of employment which are free from recognized hazards that are causing or are likely to cause death or serious physical harm to his employees;

(2) shall comply with occupational safety and health standards promulgated under this Act.

(b) Each employee shall comply with occupational safety and health standards and all rules, regulations and orders issued pursuant to this Act which are applicable to his own actions and conduct.

### **OSHA Training Requirements**

***Title 29, Code of Federal Regulations Part 1928.57(a)(6).*** [www.osha.gov](http://www.osha.gov)

Operator instructions. At the time of initial assignment and at least annually thereafter, the employer shall instruct every employee who operates an agricultural tractor and implements in the safe operating practices and servicing of equipment with which they are or will be involved, and of any other practices dictated by the work environment.

Keep all guards in place when the machine is in operation;

Permit no riders on equipment

Stop engine, disconnect the power source, and wait for all machine movement to stop before servicing, adjusting, cleaning or unclogging the equipment, except where the machine must be running to be properly serviced or maintained, in which case the employer shall instruct employees as to all steps and procedures which are necessary to safely service or maintain the equipment.

Make sure everyone is clear of machinery before starting the engine, engaging power, or operating the machine.

### **Employer Responsibilities:**

To ensure employee safety during Tractor and Implement operation, it is the employer's responsibility to:

1. Train the employee in the proper and safe operation of the Tractor and Implement.
2. Require that the employee read and fully understand the Tractor and Implement Operator's Manual.
3. Permit only qualified and properly trained employees to operate the Tractor and Implement.
4. Maintain the Tractor and Implement in a safe operational condition and maintain all shields and guards on the equipment.
5. Ensure the Tractor is equipped with a functional ROPS and seat belt and require that the employee operator securely fasten the safety belt and operate with the ROPS in the raised position at all times.
6. Forbid the employee operator to carry additional riders on the Tractor or Implement.
7. Provide the required tools to maintain the Tractor and Implement in a good safe working condition and provide the necessary support devices to secure the equipment safely while performing repairs and service.
8. Require that the employee operator stop operation if bystanders or passersby come within 300 feet.

### **Child Labor Under 16 Years of Age**

Some regulations specify that no one under the age of 16 may operate power machinery. It is your responsibility to know what these regulations are in your own area or situation. (Refer to U.S. Dept. of Labor, Employment Standard Administration, Wage & Home Division, Child Labor Bulletin #102.)



# **INTRODUCTION SECTION**

Introduction Section 2-1

# INTRODUCTION

## INTRODUCTION

This Bush Hog PHDHF/PHDHC Model Planetary Drive Digger is designed with care and built with quality materials by skilled workers. Proper assembly, maintenance, and operating practices, as described in this manual, will help the owner/operator get years of satisfactory service from the machine.

Proper assembly, maintenance, and operating practices, as described in this manual, will help the owner/operator get years of satisfactory service from the machine. The purpose of this manual is to familiarize, instruct, and train. The Assembly Section instructs the owner/operator in the correct assembly of the Post Hole Digger.

Careful use and timely service saves extensive repairs and costly downtime losses. The Operation and Maintenance Sections of the manual train the owner/operator how to work the implement correctly and attend to appropriate maintenance. The Trouble Shooting Guide helps diagnose difficulties with implement and offers solution to the problems.

Safety is of primary importance to the owner/operator and to the manufacturer. The first section of this manual includes a list of Safety Messages, that, if followed, will help protect the operator and bystanders from injury or death. Many of the Safety Messages will be repeated throughout the manual. The owner/operator/dealer should know these Safety Messages before assembly and be aware of the hazards of operating this implement during assembly, use, and maintenance. The Safety Alert Symbol combined with a Signal Word, as seen below, is intended to warn the owner/operator of impending hazards and the degree of possible injury faced when operating this machine.



Indicates a hazardous situation that, if not avoided, WILL result in DEATH OR VERY SERIOUS INJURY.



Indicates a hazardous situation that, if not avoided, COULD result in DEATH OR SERIOUS INJURY.



Indicates a hazardous situation that, if not avoided, MAY result in MINOR OR MODERATE INJURY.



Identifies special instructions or procedures that, if not strictly observed, could result in damage to, or destruction of the machine, attachments or the environment.



# INTRODUCTION

## PHDHF SERIES



FC-C-0003

## PHDHF-2 SERIES



FC-D-0005

## PHDHC SERIES



FC-D-0004

The Bush Hog Planetary Drive Digger features a high torque level to power the auger through the most demanding conditions. All augers are heavy industrial grade with 3/8" thick flighting. Sized in diameters from 6" to 36" (depending on model). These are excellent for all soil conditions, including compacted soils, frozen ground, solid rock and concrete. Mount kits are available to mount to most skid steer loaders, front-end loader buckets and backhoes. The PHDHF15 digger is designed for 6-15 GPM, the PHDHF20 is for units with flow rates between 10-20 GPM. The PHDHF30 is designed for units with flow rates between 15-30 GPM. The PHDHF35 is designed for units with flow rates between 20-35 GPM. The PHDHC20 digger is designed for units with flow rates between 10-20 GPM, the PHDHC30 is for units with flow rates between 15-30 GPM, and the PHDHC35 is designed for units with flow rates between 20-35 GPM.

The farm and ranch PHDHF Series features a selection of mounting brackets for skid steer loader and front end loaders.

The Commercial Grade PHDHC Series features mounting brackets for excavators, skid steer loaders, backhoes and front end loaders.

All mounting brackets have a dual swivel feature that keeps the auger vertical while digging.



At least 20% or the power unit's weight must be on the rear tires with the implement lifted to provide adequate traction for safe steering under good conditions. Slow down on hills, rough terrain, and curves.

Literature Page



[www.alqqr.com/rle](http://www.alqqr.com/rle)

# INTRODUCTION

## **ATTENTION OWNER/OPERATOR**

BEFORE OPERATING THIS MACHINE:

1. Carefully read the Operator's Manual, completely understand the Safety Messages and instructions, and know how to operate correctly both the tractor and implement.
2. Fill out the Warranty Card in full. Be sure to answer all questions, including the Serial Number of the implement. Mail within 30 days of delivery date of this implement.

**NOTE:** *Warranties are honored only if completed "Owner Registration and Warranty" forms are received by Bush Hog within thirty days of delivery of the implement.*

3. Record the Model and Serial Numbers on the Warranty page at the front of the Operator's Manual. Keep this as part of the permanent maintenance file for the implement.

 **WARNING**

**TO AVOID DEATH OR SERIOUS INJURY:**

- ONLY use genuine Bush Hog replacement parts, which have been validated and tested to use on Bush Hog equipment by the manufacturer.
- The equipment manufacturer cannot verify the material or structural integrity of third-party supplied non-genuine replacement parts.
- Using non-genuine parts can result in the part failing, creating hazardous conditions for operator and bystanders.

Contact local dealer or Bush Hog about repair parts:

2501 Griffin Ave., Selma, AL 36701  
Customer Service: 800-363-6096.  
Email: [contactus@bushhog.com](mailto:contactus@bushhog.com) [www.algqr.com/bpm](http://www.algqr.com/bpm)



 **WARNING**

**Cancer and Reproductive Harm**  
[www.P65Warnings.ca.gov](http://www.P65Warnings.ca.gov) D859

# INTRODUCTION

## LIMITED WARRANTY for PHDHC Models



INTRODUCTION

Bush Hog warrants to the original purchaser of any new Bush Hog PHDHC, purchased from an authorized Bush Hog dealer, that the equipment be free from defects in material and workmanship for a period of two (2) years full coverage and five (5) years parts only for non-commercial and commercial use from date of retail sale. The obligation of Bush Hog to the purchaser under this warranty is limited to the repair or replacement of defective parts. Replacement or repair parts installed in the equipment covered by this limited warranty are warranted for ninety (90) days from the date of purchase of such part or to the expiration of the applicable new equipment warranty period, whichever occurs later. Warranted parts shall be provided at no cost to the user at an authorized Bush Hog dealer during regular working hours. Bush Hog reserves the right to inspect any equipment or parts which are claimed to have been defective in material or workmanship.

**NOTICE:** *Bush Hog is NOT responsible for damage to augers caused by hitting underground objects (rocks, roots, etc.) or for bent augers caused by moving the tractor with the auger in the ground.*

### **DISCLAIMER OF IMPLIED WARRANTIES & CONSEQUENTIAL DAMAGES**

Bush Hog's obligation under this limited warranty, to the extent allowed by law, is in lieu of all warranties, implied or expressed, **INCLUDING IMPLIED WARRANTIES OF MERCHANTABILITY AND FITNESS FOR A PARTICULAR PURPOSE** and any liability for incidental and consequential damages with respect to the sale or use of the items warranted. Such incidental and consequential damages shall include but not be limited to: transportation charges other than normal freight charges; cost of installation other than cost approved by Bush Hog; duty; taxes; charges for normal service or adjustment; loss of crops or any other loss of income; rental of substitute equipment, expenses due to loss, damage, detention or delay in the delivery of equipment or parts resulting from acts beyond the control of Bush Hog.

### **THIS LIMITED WARRANTY SHALL NOT APPLY:**

1. To vendor items which carry their own warranties, such as engines, tires, and tubes.
2. If the unit has been subjected to misapplication, abuse, misuse, negligence, fire or other accident.
3. If parts not made or supplied by Bush Hog have been used in connection with the unit, if, in the sole judgment of Bush Hog such use affects its performance, stability or reliability.
4. If the unit has been altered or repaired outside of an authorized Bush Hog dealership in a manner which, in the sole judgment of Bush Hog, affects its performance, stability or reliability.
5. To normal maintenance service and normal replacement items such as gearbox lubricant, hydraulic fluid, worn blades, or to normal deterioration of such things as belts and exterior finish due to use or exposure.
6. To expendable or wear items such as teeth, chains, sprockets, belts, springs and any other items that in the company's sole judgment is a wear item.

NO EMPLOYEE OR REPRESENTATIVE OF BUSH HOG IS AUTHORIZED TO CHANGE THIS LIMITED WARRANTY IN ANY WAY OR GRANT ANY OTHER WARRANTY UNLESS SUCH CHANGE IS MADE IN WRITING AND SIGNED BY BUSH HOG'S SERVICE MANAGER, 2501 GRIFFIN AVE., SELMA, ALABAMA 36703.



Record the model number, serial number and date purchased. This information will be helpful to your dealer if parts or service are required.

MODEL NUMBER \_\_\_\_\_

SERIAL NUMBER \_\_\_\_\_

MAKE CERTAIN THE WARRANTY HAS BEEN FILED WITH BUSH HOG SELMA, ALABAMA

DATE OF RETAIL SALE \_\_\_\_\_



**BUSH HOG®**

# INTRODUCTION

## LIMITED WARRANTY for PHDHF Models



Bush Hog warrants to the original purchaser of any new Bush Hog PHDHF, purchased from an authorized Bush Hog dealer, that the equipment be free from defects in material and workmanship for a period of two (2) years for non-commercial, state and municipalities' use and ninety (90) days for commercial use from date of retail sale. The obligation of Bush Hog to the purchaser under this warranty is limited to the repair or replacement of defective parts. Replacement or repair parts installed in the equipment covered by this limited warranty are warranted for ninety (90) days from the date of purchase of such part or to the expiration of the applicable new equipment warranty period, whichever occurs later. Warranted parts shall be provided at no cost to the user at an authorized Bush Hog dealer during regular working hours. Bush Hog reserves the right to inspect any equipment or parts which are claimed to have been defective in material or workmanship.

**NOTICE:** *Bush Hog is NOT responsible for damage to augers caused by hitting underground objects (rocks, roots, etc.) or for bent augers caused by moving the tractor with the auger in the ground.*

### **DISCLAIMER OF IMPLIED WARRANTIES & CONSEQUENTIAL DAMAGES**

Bush Hog's obligation under this limited warranty, to the extent allowed by law, is in lieu of all warranties, implied or expressed, **INCLUDING IMPLIED WARRANTIES OF MERCHANTABILITY AND FITNESS FOR A PARTICULAR PURPOSE** and any liability for incidental and consequential damages with respect to the sale or use of the items warranted. Such incidental and consequential damages shall include but not be limited to: transportation charges other than normal freight charges; cost of installation other than cost approved by Bush Hog; duty; taxes; charges for normal service or adjustment; loss of crops or any other loss of income; rental of substitute equipment, expenses due to loss, damage, detention or delay in the delivery of equipment or parts resulting from acts beyond the control of Bush Hog.

### **THIS LIMITED WARRANTY SHALL NOT APPLY:**

1. To vendor items which carry their own warranties, such as engines, tires, and tubes.
2. If the unit has been subjected to misapplication, abuse, misuse, negligence, fire or other accident.
3. If parts not made or supplied by Bush Hog have been used in connection with the unit, if, in the sole judgment of Bush Hog such use affects its performance, stability or reliability.
4. If the unit has been altered or repaired outside of an authorized Bush Hog dealership in a manner which, in the sole judgment of Bush Hog, affects its performance, stability or reliability.
5. To normal maintenance service and normal replacement items such as gearbox lubricant, hydraulic fluid, worn blades, or to normal deterioration of such things as belts and exterior finish due to use or exposure.
6. To expendable or wear items such as teeth, chains, sprockets, belts, springs and any other items that in the company's sole judgment is a wear item.

NO EMPLOYEE OR REPRESENTATIVE OF BUSH HOG IS AUTHORIZED TO CHANGE THIS LIMITED WARRANTY IN ANY WAY OR GRANT ANY OTHER WARRANTY UNLESS SUCH CHANGE IS MADE IN WRITING AND SIGNED BY BUSH HOG'S SERVICE MANAGER, 2501 GRIFFIN AVE., SELMA, ALABAMA 36703.



Record the model number, serial number and date purchased. This information will be helpful to your dealer if parts or service are required.

MODEL NUMBER \_\_\_\_\_

SERIAL NUMBER \_\_\_\_\_

MAKE CERTAIN THE WARRANTY HAS BEEN FILED WITH BUSH HOG SELMA, ALABAMA

DATE OF RETAIL SALE \_\_\_\_\_



# **BUSH HOG®**

# INTRODUCTION

## LIMITED WARRANTY for PHDHF-2 & PHDHF35 Models



INTRODUCTION

Bush Hog warrants to the original purchaser of any new Bush Hog PHDHF, purchased from an authorized Bush Hog dealer, that the equipment be free from defects in material and workmanship for a period of four (4) years for non-commercial, state and municipalities' use and ninety (90) days for commercial use from date of retail sale. The obligation of Bush Hog to the purchaser under this warranty is limited to the repair or replacement of defective parts. Replacement or repair parts installed in the equipment covered by this limited warranty are warranted for ninety (90) days from the date of purchase of such part or to the expiration of the applicable new equipment warranty period, whichever occurs later. Warranted parts shall be provided at no cost to the user at an authorized Bush Hog dealer during regular working hours. Bush Hog reserves the right to inspect any equipment or parts which are claimed to have been defective in material or workmanship.

**NOTICE:** *Bush Hog is NOT responsible for damage to augers caused by hitting underground objects (rocks, roots, etc.) or for bent augers caused by moving the tractor with the auger in the ground.*

### **DISCLAIMER OF IMPLIED WARRANTIES & CONSEQUENTIAL DAMAGES**

Bush Hog's obligation under this limited warranty, to the extent allowed by law, is in lieu of all warranties, implied or expressed, **INCLUDING IMPLIED WARRANTIES OF MERCHANTABILITY AND FITNESS FOR A PARTICULAR PURPOSE** and any liability for incidental and consequential damages with respect to the sale or use of the items warranted. Such incidental and consequential damages shall include but not be limited to: transportation charges other than normal freight charges; cost of installation other than cost approved by Bush Hog; duty; taxes; charges for normal service or adjustment; loss of crops or any other loss of income; rental of substitute equipment, expenses due to loss, damage, detention or delay in the delivery of equipment or parts resulting from acts beyond the control of Bush Hog.

### **THIS LIMITED WARRANTY SHALL NOT APPLY:**

1. To vendor items which carry their own warranties, such as engines, tires, and tubes.
2. If the unit has been subjected to misapplication, abuse, misuse, negligence, fire or other accident.
3. If parts not made or supplied by Bush Hog have been used in connection with the unit, if, in the sole judgment of Bush Hog such use affects its performance, stability or reliability.
4. If the unit has been altered or repaired outside of an authorized Bush Hog dealership in a manner which, in the sole judgment of Bush Hog, affects its performance, stability or reliability.
5. To normal maintenance service and normal replacement items such as gearbox lubricant, hydraulic fluid, worn blades, or to normal deterioration of such things as belts and exterior finish due to use or exposure.
6. To expendable or wear items such as teeth, chains, sprockets, belts, springs and any other items that in the company's sole judgment is a wear item.

NO EMPLOYEE OR REPRESENTATIVE OF BUSH HOG IS AUTHORIZED TO CHANGE THIS LIMITED WARRANTY IN ANY WAY OR GRANT ANY OTHER WARRANTY UNLESS SUCH CHANGE IS MADE IN WRITING AND SIGNED BY BUSH HOG'S SERVICE MANAGER, 2501 GRIFFIN AVE., SELMA, ALABAMA 36703.



Record the model number, serial number and date purchased. This information will be helpful to your dealer if parts or service are required.

MODEL NUMBER \_\_\_\_\_

SERIAL NUMBER \_\_\_\_\_

MAKE CERTAIN THE WARRANTY HAS BEEN FILED WITH BUSH HOG SELMA, ALABAMA

DATE OF RETAIL SALE \_\_\_\_\_



**BUSH HOG®**



# ASSEMBLY SECTION

Assembly Section 3-1

# ASSEMBLY

ASSEMBLY

## LOADER BUCKET HITCH MOUNT ASSEMBLY (PHDHF & PHDHC)

1. Use bolt hole pattern of hitch mount plate and drill four 1/2" holes into side of loader bucket.
2. Place hitch mount against outside of bucket and plate to inside of bucket, align holes, and secure with 1/2" x 3" bolts (1), lockwashers (2) and locknuts (3).
3. Tighten all bolts to the recommended torque.

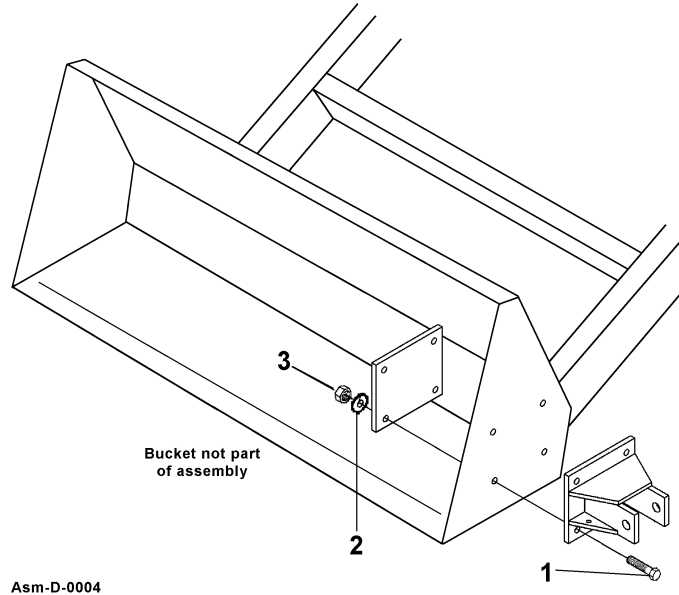

## SKID STEER HITCH ASSEMBLY (PHDHF & PHDHC)

1. Place connection pivot (2) into skid steer hitch (1) lugs and insert connecting pin (3).
2. Secure pin in place with lynch pin.

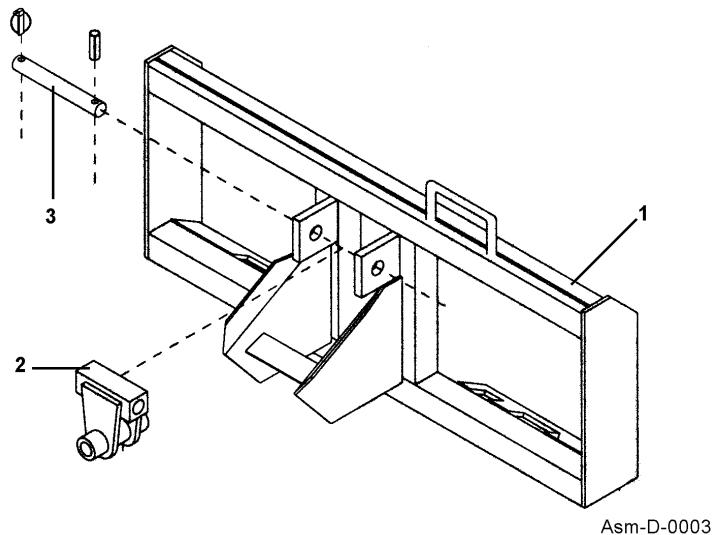



# ASSEMBLY

## LOADER BUCKET HITCH MOUNT ASSEMBLY (PHDHF-2 & PHDHF35)

1. Use bolt hole pattern of hitch mount plate and drill four 1/2" holes into side of loader bucket.
2. Place hitch mount against outside of bucket and plate to inside of bucket, align holes, and secure with 1/2" x 3" bolts (1), lockwashers (2) and locknuts (3).
3. Tighten all bolts to the recommended torque..

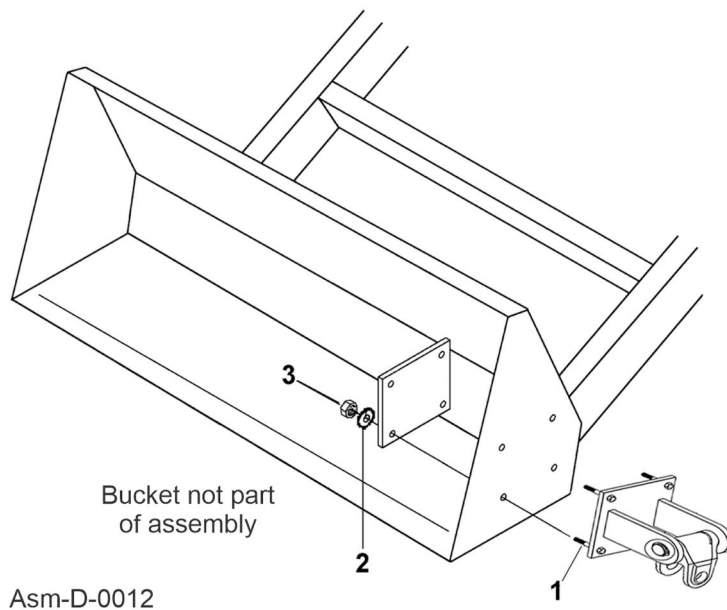

## SKID STEER HITCH ASSEMBLY (PHDHF-2 & PHDHF35)

1. Place connection pivot (2) into skid steer hitch (1) lugs and insert connecting pin (3).
2. Secure pin in place with lynch pin.

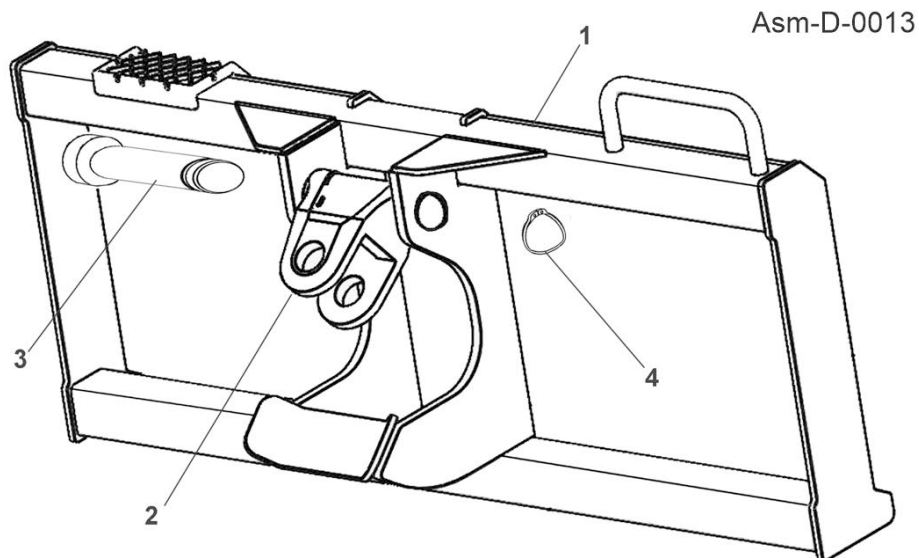

# ASSEMBLY

ASSEMBLY

## ATTACHING AUGER TO GEARBOX OUTPUT SHAFT

1. Align auger shaft hole and gearbox drive stem hole.
2. Insert 3/4" x 4-1/2" Gr. 5 capscrew through shaft and drive stem holes and secure in place with 3/4" hex nut and 3/4" lockwasher.



Asm-D-0004

## ATTACHING DRIVE MOTOR TO HITCH MOUNT

1. Align the drive motor housing assembly with connecting point on bucket, skid steer, or backhoe boom hitch.
2. Insert pin through hitch connection and motor housing and secure in place with lynch pin.

## BACKHOE HYDRAULIC DRILL UNIT

TURN YOUR BACKHOE INTO A POWERFUL DRILL WITH THE BELLTEC HYDRAULIC DRILL UNIT

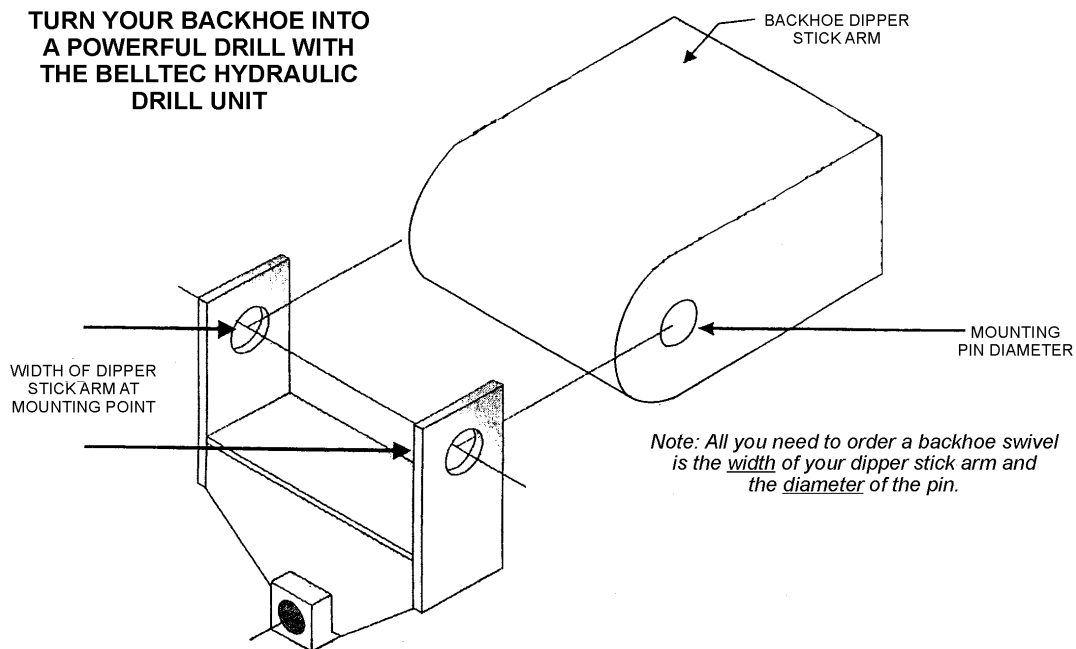

Asm-D-0011

# OPERATION SECTION

Operation Section 4-1

# OPERATION

## BUSH HOG PHDHF15, PHDHF20 PHDHF30 BUSH HOG PHDHF15-2, PHDHF20-2, PHDHF30-2, PHDHF35 BUSH HOG PHDHC20, PHDHC30, PHDHC35 PLANETARY DRIVE DIGGER OPERATING INSTRUCTIONS

The Bush Hog F-Series hydraulic auger drives are available in three models for systems operating between 6 and 30 GPM and 2000 to 3000 PSI. F-Series auger drives are designed with a planetary gearbox to eliminate chain and sprocket reductions found on drives in this class and price range.

The Bush Hog F-2 Series hydraulic auger drives are available in four models for systems operating between 5 and 35 GPM and 2000 to 3500 PSI. F-2 series auger drives are designed with a planetary gearbox to eliminate chain and sprocket reductions found on drives in this class and price range.

The rugged F-Series and F-2 Series drive will give better service since all rotating parts are sealed away from harmful dirt and debris, and fully running in oil. These compact units are designed to give exceptional service under average digging conditions. The auger rotation can be reversed to free it if it becomes caught under an obstruction. The F-Series unit are ideal for light to moderate drilling applications.

The Bush Hog C-Series hydraulic auger drives are available in three models for systems operating between 10 and 35 GPM and 2000 to 3000 PSI. The C-Series planetary outperforms and has heavier components than any of its competitors. Mounting frame mounts to all modern skid loaders with the universal attach system. The C-Series units are ideal for the toughest applications, from dirt to solid rock and concrete when paired with the correct C-Series auger. The Bolt-on Shaft reduces downtime and costly repairs due to bent or broken shafts.

This section of the Operator's Manual is designed to familiarize, instruct, and educate safe and proper implement use to the operator. Pictures contained in this section are intended to be used as a visual aid to assist in explaining the operation of a digger. Some pictures may show shields removed for purposes of clarity. NEVER OPERATE this implement without all shields in place and in good operational condition. The operator must be familiar with the implement and tractor operation and all associated safety practices before operating the implement and tractor. Proper operation of the digger, as detailed in this manual, will help ensure years of safe and satisfactory use of the implement.

**IMPORTANT:** To avoid implement damage, re-torque all bolts after the first 10 hours of operation.

**READ AND UNDERSTAND THE ENTIRE OPERATING INSTRUCTIONS AND SAFETY SECTION OF THIS MANUAL AND THE TRACTOR MANUAL BEFORE ATTEMPTING TO USE THE TRACTOR AND IMPLEMENT.** If you do not understand any of the instructions, contact your nearest authorized dealer for a full explanation. Pay close attention to all safety signs and safety messages contained in this manual and those affixed to the implement and tractor. *OPS-U- 0001str*

READ, UNDERSTAND, and FOLLOW the following Safety Messages. Death or serious injury may occur unless care is taken to follow the warnings and instructions stated in the Safety Messages. Always use good common sense to avoid hazards. (SG-2str)



Si no lee ingles, pida ayuda a alguien que si lo lea para que le traduzca las medidas de seguridad. (SG-3) str

¡ LEA EL INSTRUCTIVO!



# OPERATION

**OPERATION**

## 1. STANDARD EQUIPMENT AND SPECIFICATIONS

	PHDHF15	PHDHF20	PHDHF30
<b>Maximum Output Torque</b>	1419 ft-lbs	1777 ft-lbs	2623 ft-lbs
<b>Recommended Fluid Flow</b>	6-15 GPM	10-20 GPM	15-30 GPM
<b>Maximum Pressure Continuous</b>	3000 PSI	3000 PSI	3000 PSI
<b>Recommended Max Auger Dia Rock</b>	---	9 inch	12 inch
<b>Recommended Max Auger Dia Dirt</b>	18 inch	30 inch	36 inch
<b>Output Speed - Flow/Speed</b>	6 GPM/39 RPM	10 GPM/52 RPM	15 GPM/53 RPM
	8 GPM/52 RPM	12 GPM/62 RPM	18 GPM/63 RPM
	10 GPM/65 RPM	14 GPM/73 RPM	20 GPM/70 RPM
	12 GPM/78 RPM	16 GPM/83 RPM	24 GPM/84 RPM
	14 GPM/91 RPM	18 GPM/93 RPM	28 GPM/101 RPM
	15 GPM/104 RPM	20 GPM/104 RPM	30 GPM/108 RPM
<b>Output Torque - Pressure/Torque</b>	2000 PSI/946 lb-ft	2000 PSI/1185 lb-ft	2000 PSI/1748 lb-ft
	2500 PSI/1182 lb-ft	2500 PSI/1481 lb-ft	2500 PSI/2185 lb-ft
	3000 PSI/1419 lb-ft	3000 PSI/1777 lb-ft	3000 PSI/2623 lb-ft
	PHDHC20	PHDHC30	PHDHC35
<b>Maximum Output Torque</b>	2008 ft-lbs	2937 ft-lbs	3582 ft-lbs
<b>Recommended Fluid Flow</b>	10-20 GPM	15-30 GPM	20-30 GPM
<b>Maximum Pressure Continuous</b>	3000 PSI	3000 PSI	3000 PSI
<b>Recommended Max Auger Dia Rock</b>	24 inch	36 inch	36 inch
<b>Recommended Max Auger Dia Dirt</b>	30 inch	36 inch	36 inch
<b>Output Speed - Flow/Speed</b>	10 GPM/48 RPM	15 GPM/47 RPM	20 GPM/51 RPM
	12 GPM/55 RPM	18 GPM/56 RPM	24 GPM/62 RPM
	14 GPM/64 RPM	22 GPM/68 RPM	26 GPM/67 RPM
	16 GPM/73 RPM	26 GPM/81 RPM	28 GPM/72 RPM
	18 GPM/82 RPM	28 GPM/87 RPM	30 GPM/77 RPM
	20 GPM/92 RPM	30 GPM/93 RPM	35 GPM/90 RPM
<b>Output Torque - Pressure/Torque</b>	2000 PSI/1339 lb-ft	2000 PSI/1958 lb-ft	2000 PSI/2388 lb-ft
	2200 PSI/1480 lb-ft	2200 PSI/2066 lb-ft	2500 PSI/2985 lb-ft
	2400 PSI/1607 lb-ft	2400 PSI/2350 lb-ft	3000 PSI/3582 lb-ft
	2600 PSI/1740 lb-ft	2600 PSI/2546 lb-ft	
	2800 PSI/1874 lb-ft	2800 PSI/2742 lb-ft	
	3000 PSI/2008 lb-ft	3000 PSI/2937 lb-ft	

# OPERATION

**OPERATION**

	<b>PHDHF15-2</b>	<b>PHDHF20-2</b>	<b>PHDHF30-2</b>
<b>Maximum Output Torque</b>	1784 ft-lbs	2038 ft-lbs	2929 ft-lbs
<b>Recommended Fluid Flow</b>	5-15 GPM	10-20 GPM	15-30 GPM
<b>Maximum Pressure Continuous</b>	3000 PSI	3000 PSI	3000 PSI
<b>Recommended Maxi Auger Dia Rock</b>	18 inch	24 inch	36 inch
<b>Recommended Max Auger Dia Dirt</b>	18 inch	30 inch	36 inch
<b>Output Speed - Flow/Speed</b>	5 GPM/31 RPM	10 GPM/53 RPM	15 GPM/55 RPM
	10 GPM/61 RPM	15 GPM/79 RPM	20 GPM/73 RPM
	15 GPM/91 RPM	20 GPM/105 RPM	25 GPM/92 RPM
			30 GPM/110 RPM
<b>Output Torque - Pressure/Torque</b>	2000 PSI/1008 lb-ft	2000 PSI/1165 lb-ft	2000 PSI/1674 lb-ft
	2500 PSI/1260 lb-ft	2500 PSI/1456 lb-ft	2500 PSI/2092 lb-ft
	3000 PSI/1512 lb-ft	3000 PSI/1747 lb-ft	3000 PSI/2511 lb-ft
	3500 PSI/1764 lb-ft	3500 PSI/2038 lb-ft	3500 PSI/2929 lb-ft

	<b>PHDHC35</b>
<b>Maximum Output Torque</b>	3529 ft-lbs
<b>Recommended Fluid Flow</b>	20-35 GPM
<b>Maximum Pressure Continuous</b>	3000 PSI
<b>Recommended Max Auger Dia Rock</b>	36 inch
<b>Recommended Max Auger Dia Dirt</b>	36 inch
<b>Output Speed - Flow/Speed</b>	20 GPM/61 RPM
	25 GPM/76 RPM
	30 GPM/91 RPM
	35 GPM/106 RPM
<b>Output Torque - Pressure/Torque</b>	2000 PSI/2016 lb-ft
	2500 PSI/2520 lb-ft
	3000 PSI/3025 lb-ft
	3500 PSI/3529 lb-ft

# OPERATION

## 2. OPERATOR REQUIREMENTS

Safe operation of the unit is the responsibility of a qualified operator. A qualified operator has read and understands the implement and tractor Operator's Manuals and is experienced in implement and tractor operation and all associated safety practices. In addition to the safety messages contained in this manual, safety signs are affixed to the implement and tractor. If any part of the operation and safe use of this equipment is not completely understood, consult an authorized dealer for a complete explanation.

If the operator cannot read the manuals for themselves or does not completely understand the operation of the equipment, it is the responsibility of the supervisor to read and explain the manuals, safety practices, and operating instructions to the operator.

Safe operation of equipment requires that the operator wear approved Personal Protective Equipment (PPE) for the job conditions when attaching, operating, servicing, and repairing the equipment. PPE is designed to provide operator protection and includes the following safety wear:

### PERSONAL PROTECTIVE EQUIPMENT (PPE)

- Always Wear Safety Glasses (with side shields marked to comply with ANSI Z87)
- Hard Hat
- Steel Toe Safety Footwear
- Gloves
- Hearing Protection
- Close Fitting Clothing
- Respirator or Filter Mask (depends on operating conditions)

OPS-U- 0002str

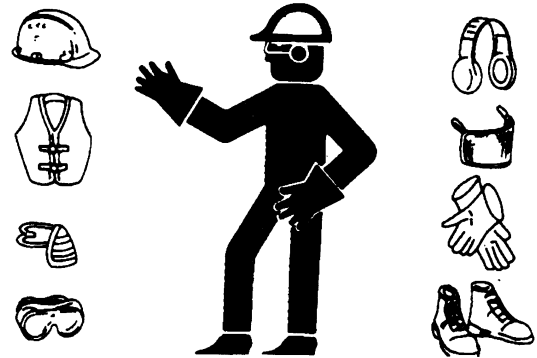

### **⚠ DANGER**

DO NOT use drugs or alcohol immediately before or while operating the Tractor and Implement. Drugs and alcohol will affect an operator's alertness and coordination and therefore affect the operator's ability to operate the equipment safely. Before operating the Tractor or Implement, an operator on prescription or over-the-counter medication must consult a medical professional regarding any side effects of the medication that would hinder their ability to operate the Equipment safely. NEVER knowingly allow anyone to operate this equipment when their alertness or coordination is impaired. Serious injury or death to the operator or others could result if the operator is under the influence of drugs or alcohol.

(SG-27) str

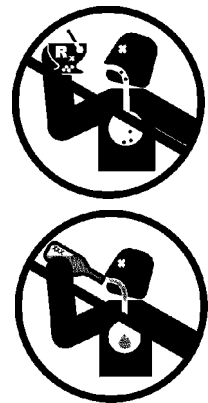

# OPERATION

OPERATION

## 3. POWER UNIT REQUIREMENTS

The power unit used to operate the digger must have the power capacity to lift, pull, and operate the Power Take Off (PTO) at the implement's rated speed while traveling at a ground speed between 2 and 5 MPH. Operating the implement with a power unit that does not meet the following requirements may cause power unit or implement damage and be a potential danger to the operator and passersby.

### Tractor Requirements and Capabilities

- ASABE approved Roll-Over Protective Structure (ROPS) or ROPS cab and seat belt.
- Tractor Safety Devices ..... Slow Moving Vehicle (SMV) emblem, lighting, PTO master shield
- Auxiliary Hydraulics ..... Planetary Digger Model must match the hydraulic output capacity of the power unit operating the digger
- Digger Model:
  - PHDHF15..... For Systems delivering 6-15 GPM at 3000 PSI Max.  
1419 ft./lbs. torque at 3000 PSI
  - PHDHF20..... For Systems delivering 10-20 GPM at 3000 PSI Max.  
1777 ft./lbs. torque at 3000 PSI
  - PHDHF30..... For Systems delivering 15-30 GPM at 3000 PSI Max.  
2632 ft./lbs. torque at 3000 PSI
  - PHDHC20 ..... For Systems delivering 10-20 GPM at 3000 PSI Max.  
2008 ft./lbs. torque at 3000 PSI
  - PHDHC30 ..... For Systems delivering 15-30 GPM at 3000 PSI Max.  
2937 ft./lbs. torque at 3000 PSI
  - PHDHC35 ..... For Systems delivering 20-35 GPM at 3000 PSI Max.  
3582 ft./lbs. torque at 3000 PSI
  - PHDHF15-2..... For Systems delivering 5-15 GPM at 3500 PSI Max.  
1764 ft./lbs. torque at 3500 PSI
  - PHDHF20-2..... For Systems delivering 10-20 GPM at 3500 PSI Max.  
2038 ft./lbs. torque at 3500 PSI
  - PHDHF30-2..... For Systems delivering 15-30 GPM at 3500 PSI Max.  
2929 ft./lbs. torque at 3500 PSI
  - PHDHF35..... For Systems delivering 20-35 GPM at 3500 PSI Max.  
3529 ft./lbs. torque at 3500 PSI

### 3.1 ROPS and Seat Belt

The tractor must be equipped with a Roll-Over-Protective-Structure (ROPS), tractor cab, or roll-bar and seat belt to protect the operator from falling off the tractor, especially during a roll over where the driver could be crushed and killed. Only operate the tractor with the ROPS in the raised position and seat belt fastened. Tractor models not equipped with a ROPS and seat belt should have these life saving features installed by an authorized dealer. OPS-U- 0003str



Operate this Equipment only with a Power Unit equipped with an approved operator Roll-Over Protective Structure (ROPS). Always wear seat belts. Serious injury or even death could result from falling off the Power Unit--particularly during a turnover when the operator could be pinned under the Operator Protective Structure. (SPU-14) str





# OPERATION



Do not operate the unit under any circumstance if the slope is 10 degrees or greater.

## **3.2 Power Unit Safety Devices**

If transporting or operating the power unit and implement near a public roadway, the power unit must be equipped with proper warning lighting and a Slow Moving Vehicle (SMV) emblem which are clearly visible from the rear of the unit. Lights and an SMV emblem must be equipped directly on implements if the visibility of the tractor warning signals are obscured.

Maintain all manufacturer equipped safety shields and guards. Always replace shields and guards that were removed for access to connect, service, or repair the power unit or implement. *OPS-UPI- 0004 str*

## **3.3 Auxiliary Hydraulics**

The power unit must be equipped with auxiliary hydraulics and be rated for the hydraulic flow rating of the digger model being used. Reference the power unit operator's manual to determine the hydraulic output specifications of the power unit.

Common hydraulic connection points for most power units are given below. Consult an authorized dealer if there are any questions on where to tap into the hydraulic system for your equipment

Skid Steer Loaders

- Boom auxiliary outlets

Backhoes

- Auxiliary hydraulic outlets or bucket curl cylinder circuit

Loader Buckets

- Auxiliary hydraulic outlets or bucket tilt (dump) cylinder circuit

**NOTE:** *Some auxiliary outlets on these power units are one way circuits and turn on flow abruptly with such force that it can cause damage to hydraulic motors and other parts of the system and will not reverse the motor to free the auger in instances where it becomes lodged. Check this before installing on one of the power unit outlets.*

Determine the length of hose required to plumb the drive unit into the power unit hydraulic outlets. Be sure hydraulic hoses are long enough to perform at the full range of the digger's operating capacity. The digger hydraulic hose quick couplers must be compatible with the couplers of the power unit. Hydraulic hoses and fittings must have a continuous operating pressure rating of at least 25% higher than the maximum pressure of the hydraulic system that the digger will be tapped into. *OPS-PHD- 0001 str*

# OPERATION

## 4. GETTING ON AND OFF THE POWER UNIT

Before getting onto the power unit, the operator must read and completely understand the implement and power unit operator manuals. If any part of either manual is not completely understood, consult an authorized dealer for a complete explanation. *OPS-UPI-0005 str*



Do not mount the Power Unit while the Power Unit is moving. Mount the Power Unit only when the Power Unit and all moving parts are completely stopped. *(SPU-18) str*



### 4.1 Boarding the Power Unit

Use both hands and equipped handrails and steps for support when boarding the power unit. Never use control levers for support when mounting the power unit. Always seat yourself in the operator's seat and secure the seat belt around you. Only operate the power unit and implement with the ROPS in the raised position.

Never allow passengers to ride on the power unit or digger. Extra riders can easily fall off and be seriously injured or killed from falling off and being ran over. It is the operator's responsibility to forbid all extra riders. *OPS-UPI-0006 str*



Never allow children or other persons to ride on the Power Unit or Implement. Falling off can result in serious injury or death. *(SPU-16) str*



Never allow children to operate, ride on, or come close to the Tractor or Implement. Usually, 16-17 year-old children who are mature and responsible can operate the implement with adult supervision, if they have read and understand the Operator's Manuals, been trained in proper operation of the tractor and Implement, and are physically large enough to reach and operate the controls easily. *(SG-11) str*



### 4.2 Dismounting the Power Unit

Before dismounting, park the power unit and implement on a reasonably level surface, apply the parking brake, idle the engine down, disengage the PTO, and lower the implement to the ground. Shut down the power unit engine according to the operator's manual, remove the key, and wait for all motion to completely stop. Never leave the seat until the power unit, its engine and all moving parts have come to a complete stop.

Use hand rails and steps when exiting the power unit. Be careful of your step and use extra caution when mud, ice, snow or other matter has accumulated on the steps or hand rails. Use all handrails and steps for support and never rush or jump off the power unit. *OPS-UPI-0007 str*

# OPERATION

## **5. STARTING THE POWER UNIT**

The operator must have a complete understanding of the placement, function, and operational use of all power unit controls before starting the power unit. Review the power unit operator's manual and consult an authorized dealer for power operation instructions if needed.

### **Essential Power Unit Controls:**

- Locate the light control lever.
- Locate the engine shut off control.
- Locate the brake pedals and clutch.
- Locate the hydraulic remote control levers

### **Before starting the power unit ensure the following:**

- Conduct all pre-start operation inspection and service according to the power unit operator's manual.
- Make sure all guards, shields, and other safety devices are securely in place.
- The parking brake is on.
- The hydraulic remote control levers are in the neutral position.
- The power unit transmission levers are in park or neutral.

Refer to the power unit owner's manual for power unit starting procedures. Only start the power unit while seated and belted in the operator's seat. Never bypass the ignition switch by short circuiting the starter solenoid. After the power unit engine is running, avoid accidental contact with the power unit transmission to prevent sudden and unexpected power unit movement. *OPS-UPI-0009 str*



Never run the Tractor engine in a closed building or without adequate ventilation. The exhaust fumes can be hazardous to your health. (SG-23) str



Start the Power Unit only when properly seated in the Power Unit seat. Starting a Power Unit in gear can result in injury or death. Read the Power Unit Operator's Manual for proper starting instructions. (SPU-19) str



# OPERATION

## 6. PRE-OPERATION INSPECTION AND SERVICE

Before each use, a pre-operation inspection and service of the implement and power unit must be performed. This includes routine maintenance and scheduled lubrication, inspecting that all safety devices are equipped and functional, and performing needed repairs. Do not operate the implement and power unit if the pre-operation inspection reveals any condition affecting safe operation. Perform repairs and replacement of damaged and missing parts as soon as noticed. By performing a thorough pre-operation inspection and service, valuable down time and repair cost can be avoided. *OPS-UPI-0008 str*



Always disconnect the auxiliary hydraulic couplers from the Power Unit before performing service on the Implement. Never work on the Implement with the Power Unit auxiliary hydraulics connected. Rotating parts could turn without warning and cause immediate entanglement, injury or death. (SPU-31) str



Periodically inspect all moving parts for wear and replace when necessary with authorized service parts. Look for loose fasteners, worn or broken parts, and leaky or loose fittings. Make sure all pins have cotter pins and washers. Serious injury may occur from not maintaining this machine in good working order. (SG-21) str

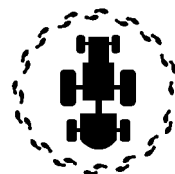

### 6.1 Power Unit Pre-Operation Inspection/Service

Refer to the power unit operator's manual to ensure a complete pre-operation inspection and scheduled service is performed according to the manufacturers recommendations. The following are some of the items that require daily service and inspection:

- Tire condition/air pressure
- Wheel lug bolts
- Steering linkage
- SMV sign is clean and visible
- Seat belt is in good condition
- ROPS is in good condition
- ROPS is in the raised position
- No oil leaks
- Radiator free of debris
- Engine oil level and condition
- Engine coolant level and condition
- Power brake fluid level
- Power steering fluid level
- Fuel condition and level
- Sufficient lubrication at all lube points
- Air filter condition OPS-UPI-0010 str



# OPERATION

## 6.2 Digger Pre-Operation Inspection/Service

Before each digger use, a complete inspection and service is required to ensure the digger is in a good and safe working condition. Damaged and/or broken parts should be repaired and/or replaced immediately. To ensure the digger is ready for operation, conduct the following:

The operator's manual and safety signs affixed on the unit contain important instructions on the safe and proper use of the equipment. Maintain these important safety features on the implement in good condition to ensure the information is available to the operator at all times.

- Ensure the manual canister has been located in area convenient for operator access
- Ensure all safety signs are in place and legible. Replace missing, damaged, and illegible decals. *OPS-PHD- 0003 str*



The operator's manual and decals affixed on the unit contain important instructions on the safe and proper use of the equipment. Maintain these important safety features on the implement in good condition to ensure the information is available to the operator at all times.

- Ensure the digger hitch is securely attached to the power unit.
- Check for hydraulic oil leaks on the drive motor, along the hydraulic lines, and at the hydraulic ports. .

**IMPORTANT:** *DO NOT use your hands to check for oil leaks. Use a piece of heavy paper or cardboard to check for hydraulic leaks.*

- Inspect planetary reduction gear oil level and replenish if needed. A low oil level is a warning sign that the gearbox may be cracked or its seal is damaged and needs to be replaced. *OPS-PHD- 0002\_A str*



# OPERATION

## HYDRAULIC POST HOLE DIGGER PRE-OPERATION INSPECTION



Digger ID# \_\_\_\_\_ Make: \_\_\_\_\_

Date: \_\_\_\_\_ Shaft: \_\_\_\_\_



**WARNING**

Before conducting the inspection, make sure the tractor engine is off, all rotation has stopped and the tractor is in park with the parking brake engaged. Make sure the Post Hole Digger is resting on the ground or securely blocked up and all hydraulic pressure has been relieved.

OPERATION

Item	Condition at Start of Shift	Specific Comments if not OK
The Operator's Manual is in the Canister on the Digger		
All Safety Decals are in place and legible		
The attachment mounting bolts and pins are tight		
There are no cracks in mounting members		
There are no cracks in the Post Hole Digger frame		
The hydraulic cylinder pins are properly retained		
There are no leaking or damaged hoses		
Auger connection guards are in place and in good condition		
Gearbox mounting pins/bolts are in place & in good condition		
Gearbox oil is at the proper level		
The auger connection bolts are in place and guarded		
The auger blades are not chipped, cracked or bent		
The auger blade bolts are tight		
The auger is clear of caked mud and debris		

Operator's Signature: \_\_\_\_\_

**DO NOT OPERATE an UNSAFE TRACTOR or MOWER**

# OPERATION

## 7. OPERATING THE POWER UNIT AND IMPLEMENT

**THE OPERATOR MUST COMPLETELY UNDERSTAND HOW TO OPERATE THE POWER UNIT AND IMPLEMENT AND ALL CONTROLS BEFORE STARTING TO DIG.**

The operator must read and understand the Safety and Operation Sections of the implement and power unit operator's manuals. These manuals must be read and explained to any operator who cannot read. Never allow someone to operate the implement and power unit without complete operating instructions.

Before starting any digging operation, the operator must become familiar with the area and any obstacles and hazards contained within to ensure safety to the operator, bystanders, and equipment. *OPS-UPI- 0011str*



KEEP AWAY FROM ROTATING ELEMENTS to prevent entanglement and possible serious injury or death. (SPHD-2) str



Never move from hole-to-hole or transport with Auger rotating to prevent possible instantaneous driveline failure that could lead to being hit by the disconnected parts or to entanglement and cause serious injury or death. (SPHD-10) str

# OPERATION

## 7.1 Digger Operating Instructions

1. Spot auger pilot over mark where hole is to be drilled. LOCK POWER UNIT BRAKES - if power unit rolls forward or backwards with auger in the ground, the auger, gearbox, or hitch may be damaged or broken.
2. With auger raised off the ground less than 12", and the power unit engine set at a lower RPM, activate the digger hydraulic control valve to determine position control lever must be in to turn auger in forward (clockwise) rotation. This is the "digging" position.
3. Before beginning to dig, experiment with auger speed to determine a suitable auger RPM. Generally in light and sandy soils a high RPM is needed. To increase auger RPM, increase the power unit engine RPM. To decrease auger rotation speed, decrease power unit engine RPM.
4. Return digger hydraulic control lever to neutral position to stop the auger rotation. Lower the auger to the ground so that only the center point penetrates the ground above 2".
5. Activate the hydraulic control lever to digging position to start auger turning in a forward (clockwise) rotation. Use only enough down pressure to assure positive penetration of auger into the ground. Ease up on down pressure if auger rotation slows down drastically or stalls.
6. After the auger has penetrated the ground about 24", raise the auger from hole to clean dirt out. Repeat this procedure until the desired hole depth is achieved. Allow auger to turn a few seconds at this depth to clean the hole.
7. Return digger hydraulic control valve to the neutral position to disengage the auger and stop rotation. With auger at a complete stop, raise auger out of the hole, move auger away from the hole, and re-engage to spin loose soil off the auger flighting.

**NOTE:** Do not reverse the auger direction to remove the auger from the hole as loose soil or the auger will fall back in the hole.

8. If necessary, repeat steps 6 and 7 to obtain a cleaner hole.
9. In some digging conditions or when excessive down pressure is applied, the auger may "screw" itself into the ground and become stuck causing the digger to stall. When this happens, reverse the auger rotation (move hydraulic control lever in opposite direction so that auger turns counter-clockwise) and slowly raise the auger out of the hole. Once unstuck, return the control valve lever to the forward rotation position to resume digging.

If the auger becomes lodged under rocks, roots or other large obstruction, do not attempt to raise the auger out of the hole. The auger must be rotated in the reverse direction to unscrew the flighting from the obstruction.

10. If the auger hits and becomes lodged with a large obstruction, the power unit hydraulic relief valve will open and bypass the oil to stall (stop) the auger. This does not damage the digger or power unit in any way but serves as an overload protection device. When this happens, simply reverse the auger rotation and slowly raise the auger. The relief valve will reset automatically, and the drilling operation can be resumed.
11. Avoid excessive shield loading to the auger and drive motor which can cause drive unit, auger and hitch damage.
12. Keep auger teeth and points in good condition. Check condition frequently and always keep spare teeth readily available so that worn and missing teeth can be replaced as detected to avoid damage to tooth holders and auger flighting.



# OPERATION

## 7.2 Auger Selection Based On Drilling Application

The digger must be equipped with the proper auger type for the drilling application at hand. A wide range of augers and sizes are available for drilling in compacted soils, frozen ground, and loose and solid rock. In some applications the digger can be used to drill concentrate (without rebar) if adequate down pressure can be applied to the auger by the power unit (not recommended for skid steer operated units).

**PUFF Auger:** Designed to drill 2" diameter holes in solid rock or concrete for T-posts. Also referred to as the T-post Puff Auger.

**SDA Augers:** Designed for digging in soil only. Available in sizes from 6" to 36" diameter, and tree augers from 18" to 36" diameter sizes.

**RAD Augers:** Designed for digging in soil, clay, loose and solid rock and concrete. Available in sizes from 9" to 36" diameter.

**SRA Augers:** Designed for drilling in solid rock or concrete without rebar, fractured rock, frozen ground and compacted soil. Augers are available in sizes from 4.5" to 6" diameter.

### Maximum Diameter Auger Sizes for Digger Model

DIGGER	DIRT	ROCK
PHDHC20	36"	24"
PHDHC30	36"	36"
PHDHC35	36"	36"
PHDHF15	18"	N/A
PHDHF20	30"	9"
PHDHF30	36"	12"
PHDHF15-2	30"	24"
PHDHF20 -2	30"	24"
PHDHF30-2	36"	36"
PHDHF35	36"	36"

PUFF\*\*



SDA\*\*



RAD\*



SRA\*



Ops-2011

\* Available for C-Series Planetary Drive Diggers

\*\* Available for H-Series Planetary Drive Diggers

# OPERATION

## **8.IMPLEMENT STORAGE**

Properly preparing and storing the implement at the end of the season is critical to maintaining its appearance and to help ensure years of dependable service. The following are suggested storage procedures:

- Thoroughly clean all debris off the implement to prevent damage from rotting grass and standing water.
- Check the planetary reduction gear oil level and fill as necessary.
- Tighten all bolts and pins to the recommended torque.
- Check the implement and auger for worn and damaged parts. Perform repairs and make replacements immediately so that the implement will be ready for use at the start of the next season.
- Keep hydraulic hoses from sitting in water, dirt and other contaminants..
- Use spray touch-up enamel where necessary to prevent rust and maintain the appearance of the implement. *OPS-UPI-0012 str*



Never allow children to play on or around Power Unit or Implement. Children can slip or fall off the Equipment and be injured or killed. Children can cause the Implement to shift or fall crushing themselves or others. *(SPU-24) str*

## **9.TRANSPORTING THE POWER UNIT AND IMPLEMENT**

Inherent dangers of operating the power unit and implement and the possibility of accidents are not left behind when you finish working in an area. Therefore, the operator must employ good judgment and safe operation practices when transporting the power unit and implement between locations. By using good judgment and following safe transport procedures, the possibility of accidents while moving between locations can be substantially minimized. *OPS-UPI- 0013 str*



Never allow children or other persons to ride on the Power Unit or Implement. Falling off can result in serious injury or death. *(SPU-16) str*



Before transporting the power unit on a public roadway or boarding a trailer for transport, the power brake pedals should be locked together. Locking the pedals ensures that both wheels brake simultaneously while stopping, especially when making an emergency stop.

Use extreme caution and avoid hard applications of the power unit brakes when towing heavy loads at road speeds. Never tow the implement at speeds greater than 20 MPH. *OPS-UPI- 0014 str*



# OPERATION

## 9.1 Transporting on Public Roadways

Extreme caution should be used when transporting the power unit and implement on public roadways. The power unit must be equipped with all required safety warning features including a SMV emblem and flashing warning lights to alert drivers of the power unit's presence. Remember that roadways are primarily designed for automotive drivers and most drivers will not be looking out for you, therefore, you must look out for them. Check your side view mirrors frequently and remember that vehicles will approach quickly because of the power unit's slower speed. Be extremely cautious when the piece of equipment that you are towing is wider than the power unit tire width and/or extends beyond your lane of the road. *OPS-UPI- 0015 str*



**WARNING** Make certain that the "Slow Moving Vehicle" (SMV) sign is installed in such a way as to be clearly visible and legible. When transporting the Equipment use the Tractor flashing warning lights and follow all local traffic regulations. (SG-6)str

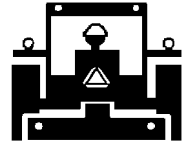

The SMV (Slow-Moving Vehicle) emblem is universal symbol used to alert drivers of the presence of equipment traveling on roadways at a slow speed. SMV signs are a triangular bright orange with reflective red trim for both easy day and night visibility. Make sure the SMV sign is clean and visible from the rear of the unit before transporting the tractor and implement on a public roadway. Replace the SMV emblem if faded, damaged, or no longer reflective. *OPS-U- 0020str*



Op-43

Make sure that all power unit flashing warning lights, headlights, and brake/tail lights are functioning properly before proceeding onto public roads. While newer model power units have plenty of lighting to provide warning signals and operating lighting, most older models are only equipped with operating lights. Consult an authorized dealer for lighting kits and modifications available to upgrade the lighting on older power unit models. *OPS-UPI-0016 str*



Op-86

# OPERATION

## OPERATION

When operating on public roads, have consideration for other road users. Pull to the side of the road occasionally to allow all following traffic to pass. Do not exceed the legal speed limit set in your country for agricultural power units. Always stay alert when transporting the power unit and implement on public roads. Use caution and reduce speed if other vehicles or pedestrians are in the area. *OPS-UPI-0017 str*



Reduce speed before turning or applying the brakes. Ensure that both brake pedals are locked together when operating on public roads. *OPS-U-0023 str*



## **9.2 Hauling the Power Unit and Implement**

Before transporting a loaded power unit and implement, measure the height and width dimensions and gross weight of the complete loaded unit. Ensure that the load will be in compliance with the legal limits set for the areas that will be traveled through. *OPS-UPI- 0018 str*



# OPERATION

Use adequately sized and rated trailers and equipment to transport the tractor and implement. Consult an authorized dealer to determine the proper equipment required. Using adequately sized chains, heavy duty straps, cables and/or binders, securely tie down both the front and rear of the tractor utilizing the proper tie down locations as specified by the tractor manufacturer. *OPS-U- 0025 str*



Arrange the chains so that when tightened, the chains are pulling downward and against themselves. Carefully tighten the securing chains or other fasteners using boomers or binders to apply maximum tension. Use extreme care when attaching and removing the securing devices as the extreme tension involved when released has the potential to inflict serious injury. While hauling the power unit and implement, make occasional stops to check that the power unit and implement have not moved or shifted and that the securing chains have maintained tension. If during transport a hard braking, sharp turning, or swerving action was performed, stop at the next safe location to inspect the security of the load. *OPS-UPI- 0020 str*



# OPERATION

**OPERATION**

## **10. TROUBLESHOOTING GUIDE**

<b>Problem</b>	<b>Possible Cause</b>	<b>Remedy</b>
<b>Gearbox Leaking</b>	Damaged oil seal.	Replace seal.
	No oil seal.	Install oil seal.
	Oil too light.	Use EP140.
	Oil seal race is rough.	Replace shaft or replace race.
	Oil seal not sealing in the housing.	Replace seal or use sealant on O.D. of seal.
	Oil seal installed wrong.	Replace seal.
	Bearing loose.	Adjust bearings.
	Oil level is too high.	Drain oil to proper level.
	Gasket damaged.	Replace gasket.
	Bolts loose.	Tighten bolts.
<b>Trouble Digging Hole</b>	Dull or broken auger teeth.	Replace damaged and missing auger teeth.
	Auger speed is too fast.	For drilling rock, slow speed down as much as possible.
	Auger is not digging vertically	Level the digger frame.
<b>Slow Speed or Insufficient Digging Power</b>	Low oil pressure or restricted oil flow.	Check pressure relief valve setting and hydraulic output by installing a combination flow and pressure gauge in hydraulic line supplying the drive motor. Gauge must be installed beyond all valves and quick disconnects to get a true reading at the drive unit. The hydraulic system flow (GPM) should remain constant and not drop off until the stall pressure (PSI) is reached. If pressure readings are not up to the power unit manufacturer's specifications, check for faulty relief valve and adjust or replace as required. A worn, damaged, or insufficient pump will also cause low oil pressure and restricted oil flow.
<b>Excessive Hydraulic Oil Heating</b>	Restricted hydraulic lines.	Clean or replace hydraulic lines.
	Oil passing over relief valve too frequently.	Decrease down pressure applied to auger.
	Insufficient hydraulic oil reservoir size to pump output ratio.	Contact power unit manufacturer for increasing reservoir size or adding oil cooler.
	Dirty or contaminated hydraulic oil.	Replace power unit hydraulic oil and hydraulic oil filters.

# MAINTENANCE SECTION

Maintenance Section 5-1

# MAINTENANCE

## MAINTENANCE

Before operating the Post Hole Digger, make sure it is properly lubricated and thoroughly inspected. Only a minimum of time and effort is required to regularly lubricate and maintain this machine to provide long life and trouble free operation.

### LUBRICATION INFORMATION

The drilling machine must be properly lubricated to achieve the best operation and longest life. Clean excess grease and hydraulic oil from the drilling machine, especially when operating in sandy conditions.

**Each day before use...**Check gearbox for signs of leaking around seals. Occasionally, seals will leak if the unit sits for a prolonged period of time. However, seals should quit leaking following a short period of operation. If seals do not quit leaking, replace seals at once and refill gearbox oil.

### ONLY USE CLEAN HYDRAULIC OIL

80% of all hydraulic component failures are caused by contamination of the hydraulic oil. Always keep all dirt and other contaminants from entering the hydraulic system. Always use dust caps and plugs on all quick disconnects when not in use. Tightly cap all hydraulic openings to hold oil in and to prevent dirt and other contaminants from entering the hydraulic system. Check condition of the hydraulic oil daily for contamination. If contamination is present, determine its source and make necessary repairs immediately.

Reduced viscosity of hydraulic fluids occurs at higher operating temperatures and causes a breakdown of fluid additives such as wear inhibitors. Excessive heat will cause higher internal leakage in the drive unit motor, resulting in less efficient motor performance. Excessive heat can also result in drive motor seals becoming brittle and cracked.

### INSPECT HYDRAULIC HOSES AND HOSE ASSEMBLIES DAILY

Excessive heat, age and exposure to the weather can cause hose covers to become brittle and to crack. Replace hoses before failure to prevent loss of hydraulic oil, time consuming "bleeding" of the system, and hydraulic oil cavitation. Operating faulty hoses increases the chances of personal injury caused by escaping hydraulic fluid during a hydraulic hose failure.

### CHECK DRIVE MOTOR DAILY

The planetary reduction gear has been filled with lubricant by the manufacturer. If oil is observed leaking, the seal should be inspected for damage or wear and replaced if necessary. Inspect gearbox for any other damage, which could be causing oil leakage, make required repairs, and refill with lubricant. When reassembled, fill the PHDHF-Series with 13.5 ounces and the PHDHC-Series with 27 ounces of fresh API-GL-5 No. 80 or 90 oil.



# MAINTENANCE

## **AUGER MAINTENANCE**

Inspect auger to loose, worn, broken and missing cutting teeth and points. Worn teeth and points can greatly affect auger penetration and greatly reduce auger life expectancy. Always keep spare teeth and points on hand. Some digging may require inspecting teeth and point condition more frequently.

On rock augers, inspect the wear of hardfacing. If worn away, re-hardface surface immediately. Failure to maintain hardfacing will allow excessive wear on pockets and will ruin auger.

## **MACHINE INSPECTION**

### **CHECK DRIVE UNIT AND ALL ACCESSORIES DAILY**

Inspect the drive unit and all accessories daily for loose, bent, cracked, or worn bolts or fasteners. Always use grade 5 or harder replacement bolts. Always use lock washers with standard hex nuts or lock nuts.

Repair or replace any worn parts immediately. Remember that drilling applicant can be hard wor, for any machine. Under extreme conditions parts can wear or break. Using any machine without proper maintenance of all parts can cause further damage to good parts.

Check to ensure that all pins and bolts are secured in place and are tightened to the proper torque.

## **STORAGE**

Your rotary mower represents an investment from which you should get the greatest possible benefit. Therefore, when the season is over, the implement should be thoroughly checked and prepared for storage so that a minimum amount of work will be required to put it back into operation for the next season. The following are suggested storage procedures:

1. Thoroughly clean the implement.
2. Lubricate the implement as covered in Maintenance Section.
3. Tighten all bolts and pins to the recommended torque.
4. Check the implement for worn or damaged parts. Make replacements immediately.
5. Store the implement in a clean, dry place with the implement housing resting on blocks.
6. Use spray touch-up enamel where necessary to prevent rust and maintain the appearance of the implement.

# MAINTENANCE

MAINTENANCE

## HYDRAULIC LINES, COUPLERS & ADAPTERS

Keep all hoses and adapters tight. Repair any leaks immediately. Do not over-tighten hose end fittings. Tighten to specifications only. (See Chart below)

RECOMMENDED HOSE END TORQUE VALUES FOR 37 DEGREE ANGLE STEEL HOSE END FITTINGS			
DASH SIZE	NOMINAL SIZE (IN.)	TORQUE (LBS.)	VALUE* (FT.LBS.)
-4	1/4	140	12
-6	3/8	230	19
-8	1/2	450	38
-10	5/8	650	54
-12	3/4	900	75
-16	1	1200	100
-20	1-1/4	1600	133
-24	1-1/2	2000	167
-32	2	2800	233

\* Straight threads do not always seal better when higher torques are used.  
Too much torque causes distortion and may lead to leakage.

Mnt-B-0004

## PROPER TORQUE FOR FASTENERS

The chart lists the correct tightening torque for fasteners. When bolts are to be tightened or replaced, refer to this chart to determine the grade of bolts and the proper torque except when specific torque values are assigned in manual text.

RECOMMENDED TORQUE IN FOOT POUNDS UNLESS OTHERWISE STATED IN THE MANUAL \*

**NOTE:** These values apply to fasteners as received from supplier, dry or when lubricated with normal engine oil. They do not apply if special graphited or molydisulphide greases or other extreme pressure lubricants are used. This applies to both UNF fine and UNC coarse threads.

# MAINTENANCE

MAINTENANCE

## TORQUE SPECIFICATIONS - DRY TORQUE

Proper torque for American fasteners.  
Recommended Torque in Foot Pounds (Newton Meters).\*

### AMERICAN

Bolt Head Markings



SAE Grade 2  
(No Dashes)

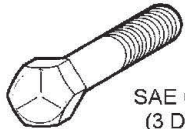

SAE Grade 5  
(3 Dashes)

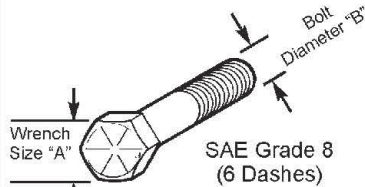

SAE Grade 8  
(6 Dashes)

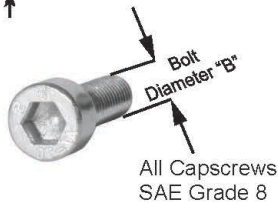

WRENCH SIZE (IN.) "A"	BOLT DIAMETER (IN.) "B" AND THREAD SIZE	SAE GRADE 2	SAE GRADE 5	SAE GRADE 8
7/16	1/4 - 20 UNC	6 (7)	8 (11)	12 (16)
7/16	1/4 - 28 UNF	6 (8)	10 (13)	14 (18)
1/2	5/16 - 18 UNC	11 (15)	17 (23)	25 (33)
1/2	5/16 - 24 UNF	13 (17)	19 (26)	27 (37)
9/16	3/8 - 16 UNC	20 (27)	31 (42)	44 (60)
9/16	3/8 - 24 UNF	23 (31)	35 (47)	49 (66)
5/8	7/16 - 14 UNC	32 (43)	49 (66)	70 (95)
5/8	7/16 - 20 UNF	36 (49)	55 (75)	78 (106)
3/4	1/2 - 13 UNC	49 (66)	76 (103)	106 (144)
3/4	1/2 - 20 UNF	55 (75)	85 (115)	120 (163)
7/8	9/16 - 12 UNC	70 (95)	109 (148)	153 (207)
7/8	9/16 - 18 UNF	79 (107)	122 (165)	172 (233)
15/16	5/8 - 11 UNC	97 (131)	150 (203)	212 (287)
15/16	5/8 - 18 UNF	110 (149)	170 (230)	240 (325)
1-1/8	3/4 - 10 UNC	144 (195)	266 (360)	376 (509)
1-1/8	3/4 - 16 UNF	192 (260)	297 (402)	420 (569)
1-5/16	7/8 - 9 UNC	166 (225)	430 (583)	606 (821)
1-5/16	7/8 - 14 UNF	184 (249)	474 (642)	668 (905)
1-1/2	1 - 8 UNC	250 (339)	644 (873)	909 (1232)
1-1/2	1 - 12 UNF	274 (371)	705 (955)	995 (1348)
1-1/2	1 - 14 UNF	280 (379)	721 (977)	1019 (1381)
1-11/16	1-1/8 - 7 UNC	354 (480)	795 (1077)	1288(1745)
1-11/16	1-1/8 - 12 UNF	397 (538)	890 (1206)	1444 (1957)
1-7/8	1-1/4 - 7 UNC	500 (678)	1120 (1518)	1817 (2462)
1-7/8	1-1/4 - 12 UNF	553 (749)	1241 (1682)	2013 (2728)
2-1/16	1-3/8 - 6 UNC	655 (887)	1470 (1992)	2382 (3228)
2-1/16	1-3/8 - 12 UNF	746 (1011)	1672 (2266)	2712 (3675)
2-1/4	1-1/2 - 6 UNC	870 (1179)	1950 (2642)	3161 (4283)
2-1/4	1-1/2 - 12 UNF	979 (1327)	2194 (2973)	3557 (4820)

### METRIC

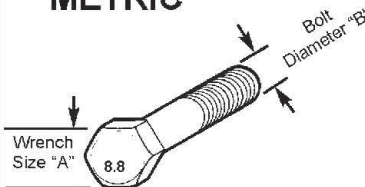

Numbers appearing on bolt heads indicate ASTM class.

\*Use 75% of the specified torque value for plated fasteners. Use 85% of the specified torque values for lubricated fasteners.

Proper torque for Metric fasteners.  
Recommended torque in Foot Pounds (Newton Meters).\*

WRENCH SIZE (mm) "A"	BOLT DIA. (mm) "B"	ASTM 4.6	ASTM 8.8	ASTM 9.8	ASTM 10.9
8	5	1.8 (2.4)		5.1 (6.9)	6.5 (8.8)
10	6	3 (4)		8.7 (12)	11.1 (15)
13	8	7.3 (10)		21.1 (29)	27 (37)
16	10	14.5 (20)		42 (57)	53 (72)
18	12	25 (34)	74 (100)	73 (99)	93 (126)
21	14	40 (54)	118 (160)	116 (157)	148 (201)
24	16	62 (84)	167 (226)	181 (245)	230 (312)
30	20	122 (165)	325 (440)		449 (608)
33	22		443 (600)		611 (828)
36	24	211 (286)	563 (763)		778 (1054)
41	27		821 (1112)		1138 (1542)
46	30	418 (566)	1119 (1516)		1547 (2096)

Mnt-B-0005





## TO THE OWNER/OPERATOR/DEALER

To keep your implement running efficiently and safely, read your manual thoroughly and follow these directions and the Safety Messages in this Manual. The Table of Contents clearly identifies each section where you can easily find the information you need.

The OCCUPATIONAL SAFETY AND HEALTH ACT (1928.51 Subpart C) makes these minimum safety requirements of tractor operators:

### REQUIRED OF THE OWNER:

1. Provide a Roll-Over-Protective Structure that meets the requirements of this Standard; and
2. Provide Seat belts that meet the requirements of this paragraph of this Standard and SAE J4C; and
3. Ensure that each employee uses such Seat belt while the tractor is moving; and
4. Ensure that each employee tightens the Seat belt sufficiently to confine the employee to the protecte-darea provided by the ROPS

### REQUIRED OF THE OPERATOR:

1. Securely fasten seat belt if the tractor has a ROPS.
2. Where possible, avoid operating the tractor near ditches, embankments, and holes.
3. Reduce speed when turning, crossing slopes, and on rough, slick, or muddy surfaces.
4. Stay off slopes too steep for safe operation.
5. Watch where you are going - especially at row ends, on roads, and around trees.
6. Do not permit others to ride.
7. Operate the tractor smoothly - no jerky turns, starts, or stops.
8. Hitch only to the drawbar and hitch points recommended by the tractor manufacturer.
9. When the tractor is stopped, set brakes securely and use park lock, if available.

**X** Keep children away from danger all day, every day...

**X** Equip tractors with rollover protection (ROPS) and keep all machinery guards in place...

**X** Please work, drive, play and live each day with care and concern for your safety and that of your family and fellow citizens.



**BUSH HOG®**

**PHDHF15, PHDHF20, PHDHF30  
PHDHF15-2, PHDHF20-2,  
PHDHF30-2, PHDHF35  
PHDHC20, PHDHC30, PHDHC35  
HYDRAULIC PLANETARY  
DRIVE DIGGER**